

# Hungarian neutral vowels\*

*Péter Dienes*

## 0 Introduction

Vowel harmony,<sup>1</sup> and especially harmonically neutral vowels always constituted a challenge to phonological theories, especially to non-linear phonologies. In this paper, I would like to take this challenge, and give a presumably universal solution to the problems raised by transparent vowels within a Government Phonological framework as it is put forth in Kaye et al. (1985, 1990), Charette (1990) and Harris (1992). I will mainly focus on Hungarian palatal harmony; nevertheless, I would like to emphasise the universality of the treatment.

In Section 1, I give a brief overview of previous accounts of harmony within the Autosegmental and Government Phonological frameworks (henceforth GP), and the problems raised by those approaches. Section 2 deals with the Hungarian data, whereas in Section 3, I develop the analysis. Section 4 shows two interesting problems and their solution, namely the cases of vacillating stems and of multiple suffixation. Finally, in Section 5, I intend to point out some theoretical consequences.

## 1 Vowel Harmony and its treatments

First, let us consider, what is meant by Vowel Harmony:

Vowel harmony is a phonological state in which the vowels of a given domain share or harmonize for a particular feature. [...] In addition, [vowel] harmony applies in an essentially unbounded fashion” (Kenstowicz 1994: 347).

Many harmonic systems have:

---

\* I would like to thank Péter Rebrus, Péter Siptár, Norval Smith and Miklós Törkenczy for their help and valuable suggestions. None of them are, of course, responsible for any of the remaining errors, especially because I refused to follow some of their suggestions.

<sup>1</sup> A summary of vowel harmonic systems can be found e.g. in van der Hulst & van de Weijer (1995). For the problematic definition of harmony, see S. R. Anderson (1980). Note, however, that my usage of the term “neutral” differs from that of van der Hulst & van de Weijer.

- (i) **opaque** vowels, which block harmony, starting a new harmonic domain, and
- (ii) **neutral** or **transparent** vowels, which do not start new domains and remain unchanged. However, they let harmony go through themselves, as if they were not present at all.

These two kinds of vowels, especially the latter, present a challenge to all theories dealing with harmony, including GP.

The initiating article of GP, Kaye et al. (1985) takes up the issue of vowel harmony within the new framework: the ATR harmony in Kpokolo. The authors, adopting the basic insights of autosegmental phonology, regard vowel harmony as the spreading of a monovalent feature on its tier, namely **I**, the ATR element in the present case. However, this analysis raises several problems, which cannot be overcome within their framework.

First of all, the unaltered adaptation of the autosegmental analysis for **opaque** vowels cannot work in the general case, GP using only unary elements instead of binary features. An autosegmental analysis of opacity would run as follows: harmony is the spreading of the [+f] (or [±f]) feature. The [-f] feature of the opaque vowel blocks this spreading, thus starts a new harmonic domain, the following vowels harmonising for [-f]. However, this analysis cannot be maintained within GP, which only recognises monovalency: harmony is the spreading of an **F** element, e.g. **I** in the case of palatal harmony. In opaque vowels we have nothing but the **lack** of this element, which cannot be claimed to block spreading, especially considering the fact that the lexical representation of the nuclei of alternating affixes – which never act opaquely – also lacks the **F** element.

The matter is further complicated, since opacity does not depend solely on the vowel itself but also on the environment in which it occurs. To clarify, leaving the details of description for the next section, let me cite some Hungarian examples:

<i>amóba</i>	‘amoeba’	<i>amóbá+nak</i>	‘amoeba+DAT’
<i>szőlő</i>	‘grapes’	<i>szőlő+nek</i>	‘grapes+DAT’

Hungarian has palatal (**I**) harmony; *a* is a short non-high vowel (*á* is its long counterpart), which acts opaquely when in the stem; and harmonises after non-neutral vowels (in the present case) if it is in the suffix (the dative *nak* in the example here) which underlyingly contains *a*. Note the failure of harmony in *amóba*.

The autosegmental analysis, again, would run like this: the reason for *a* harmonising in the suffix is that the suffixal vowel is underspecified for the feature [f] and it gets the relevant feature either by harmony or by default. However, this analysis does not work in GP, either, for two reasons:

- (i) it presupposes rule ordering, since harmony should precede the default rule, otherwise the latter would bleed the former, leading to undesirable results: this is out of the question within GP, since the theory does not recognise (ordered) rules in the traditional sense;
- (ii) it requires underspecification or abstract segments, the existence of which is again denied by the theory.

Thus, the case of opaque vowels still remains problematic for the GP approach.

So far, we have examined problems which were dealt with by autosegmental phonology easily, and turned out to be impenetrable only for the GP analysis as it was put forth by Kaye et al. (1985). However, neutral vowels challenge the classical autosegmental analysis as well, and no satisfactory solution has been given for handling them yet (cf. Kenstowicz 1994: 357ff). The analyses

- (i) either claim the spreading of the harmonic feature onto neutral segments as well: this yields an abstract segment that never surfaces due to an absolute neutralisation rule which, to complicate matters, is supposed either to divide the [-f] feature and create a [+f] feature for the neutral vowel (marked as the segment in the middle in (1)) or to operate after the autosegmental representation is turned off:

(1) Neutralisation rule

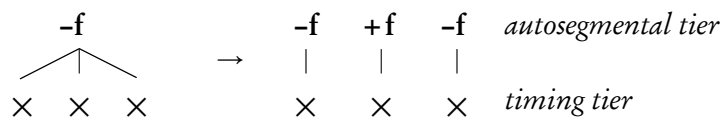

- (ii) or regard the [+f] feature of the neutral segment as residing on a different tier which is invisible for harmonic processes.

Both approaches undermine the basic insights of autosegmental theory, i.e. the independent life of the segments on their tiers. Furthermore, the existence of neutral segments shakes the building of GP, since this theory assumes that each and every phonological relationship is strictly local at the

level of some projection, whereas vowel harmony seems to be in conflict with this assumption.

Nevertheless, let me present a possible though problematic GP analysis<sup>2</sup> and point out its shortcomings. Under this view, harmony is generally regarded as the spreading of the **F** element (if any) at the level of Nuclear Projection, via government (2a and b; N<sub>s</sub> stands for a suffixal vowel). In the case of neutral vowels (N<sub>n</sub>), which are generally headed by the **F** element, this spreading fails. However, the **F** element of the previous harmonic vowel (if it has any; 2c and d, respectively) spreads to the suffixal vowel, landing on the neutral vowel as well, thus obeying strict locality. On the surface, these neutral vowels have an **F** element both in head and operator position, the latter not contributing to the phonetic interpretation of the segment.

(2) A possible analysis

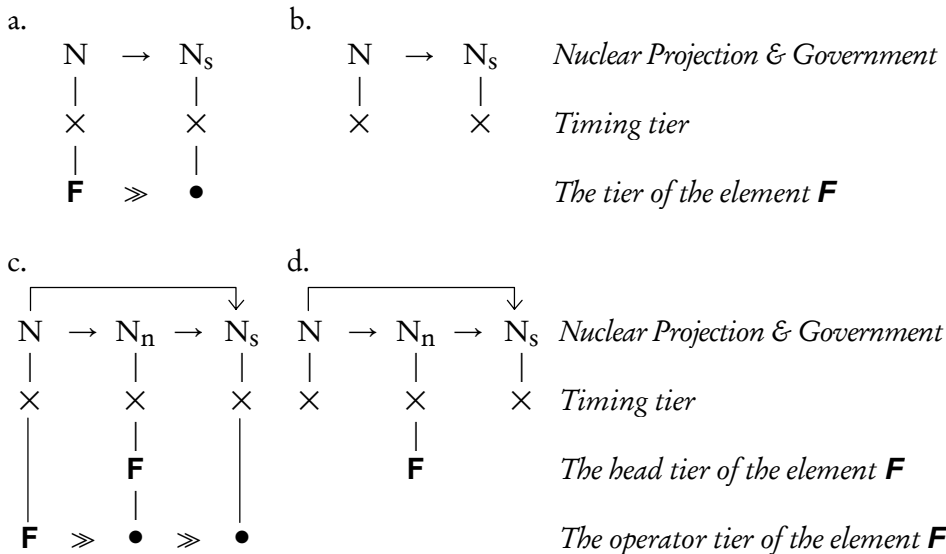

Note, however, the following defects of this analysis:

- (i) It operates with **{F.F}** structures, the existence of which is questionable, and in fact, it undermines the basic tenets of monovalency.

<sup>2</sup> This analysis might be similar to that of Demirdache (1988), quoted in Harris (1994). However, I was unable to examine it for the unavailability of the source.

- (ii) Neutrality of the nuclei  $N_n$  is marked by their segmental composition as well as by the strange kind of government relationship: one of them is redundant. Furthermore, the Strict Adjacency Condition is satisfied in a peculiar way, if it can be claimed to be satisfied at all.
- (iii) This analysis, without further stipulation, cannot account for the behaviour of stems solely containing neutral vowels, which generally take front suffixes. How does the head **F** element of the neutral vowel become active in these circumstances?

As we can see, the treatment of harmony is far from evident both within an autosegmental and a GP framework. In this paper, I offer a universal analysis within GP, which does not rely on arbitrary stipulation, and conforms to the strictest version of the theory. Beforehand, however, let me make the reader familiar with the Hungarian data.

## 2 The Hungarian data

The Hungarian<sup>3</sup> vowel inventory consists of seven short and seven long vowels (I adopt the traditional spelling throughout this paper, which indicates length by accents), which I give here together with their IPA symbols, where necessary:

### (3) Hungarian vowel inventory

<i>short vowels</i>			<i>long vowels</i>		
i	ü [y]	u	í	ű	ú
	ö [ø]	o	é	ő	ó
e [ɛ]		a [ɔ]			á [a:]

Note that the difference between the short-long pairs is quantitative in most of the cases, except for the *e-é* and *a-á* pairs: *e* is lower than *é*; *a* is mid-low whereas *á* is low. Thus, the vowel inventory, following Polgárdi & Rebrus (1996), can be represented as follows:

<sup>3</sup> For further literature on Hungarian Vowel Harmony, see e.g. Vago (1980a), Ringen (1980), Goldsmith (1985), van der Hulst (1985), Ringen (1988), Ringen & Kontra (1989), Kornai (1990, 1994), Nádasy & Siptár (1994); within GP: Dunn (1992), Ritter (1995).

(4) Representation of the Hungarian vowel system<sup>4</sup>

<i>short vowels</i>				<i>long vowels</i>		
	I. <u>U</u>	<u>U</u>			I. <u>U</u>	<u>U</u>
	A.I. <u>U</u>	A. <u>U</u>		A.I	A.I. <u>U</u>	A. <u>U</u>
A.I.		A.				<u>A</u>

Now, let us consider the alternations of the **elative** suffix:

## (5) The alternations of the elative suffix

- |      |                  |                  |
|------|------------------|------------------|
| (i)  | <i>kürt+ból</i>  | ‘from the horn’  |
|      | <i>tűz+ból</i>   | ‘from the fire’  |
|      | <i>könyv+ból</i> | ‘from the book’  |
| (ii) | <i>ház+ból</i>   | ‘from the house’ |
|      | <i>só+ból</i>    | ‘from salt’      |
|      | <i>hús+ból</i>   | ‘from meat’      |

The data shows that Hungarian has palatal (in terms of GP: **I**) harmony: **ó** {**A.U**} alternates with **ő** {**AI.U**}; (5i) illustrates the behaviour of the elative suffix after front vowels, whereas (5ii) exhibits the phenomenon after back vowels. We have the following alternations in suffixes:<sup>5</sup>

## (6) Binary suffixes

<i>Representation</i>	<i>Vowels</i>	<i>Suffixes</i>	<i>Examples</i>
<u>U</u> ~ I. <u>U</u>	u ~ ü	-unk <sub>ɟ</sub> -ünk	POSS. 1st Pl. <i>fog+unk</i> ‘our tooth’ <i>fej+ünk</i> ‘our head’
<u>U</u> ~ I. <u>U</u>	ú ~ ű	-ú <sub>ɟ</sub> -ű	DENOM. Adj. ( <i>nagy</i> ) <i>láb+ú</i> ‘big footed’ ( <i>kis</i> ) <i>fej+ű</i> ‘small headed’

<sup>4</sup> Note the difference between the representation of *a* {**A.**} and *á* {**A**}. The former is claimed to be the representation of [ɛ] in the GP literature, However, as it has nothing to do with palatal harmony, I refer the interested reader to Polgárdi & Rebrus (1996: 2ff) for arguments.

<sup>5</sup> I omit the case of ternary suffixes here, because presently I am not concerned with labial (**U**) harmony; examples taken from Polgárdi & Rebrus (1996).

<b><u>A</u> ~ <u>AI</u></b>	a ~ e	-nak <sub>ς</sub> nek	DATIVE	<i>lúd</i> + <i>nak</i>	'for the goose'
				<i>tök</i> + <i>nek</i>	'for the pumpkin'
<b><u>A</u> ~ <u>AI</u></b>	á ~ é	-nál <sub>ς</sub> nél	ADESSIVE	<i>ház</i> + <i>nál</i>	'at the house'
				<i>szék</i> + <i>nél</i>	'at the chair'
<b><u>A</u>.<u>U</u> ~ <u>AI</u>.<u>U</u></b>	ó ~ ő	-ból <sub>ς</sub> ből	ELATIVE	<i>bolt</i> + <i>ből</i>	'from the shop'
				<i>víz</i> + <i>ből</i>	'from the water'

In addition to alternating suffixes, Hungarian has a handful of non-alternating suffixes (cf. Nádasy & Siptár 1994: 68), most of them containing only neutral vowels. Note, however, the existence of some non-alternating suffixes containing back vowels: diminutives and foreign suffixes (*-ikus* '-ist' (as in *kémikus* 'chemist'), *-ia* '-y' (as in *biológia* 'biology')). Nevertheless, these suffixes usually truncate stems, and are not generally productive, thus, they are supposed to be attached within the lexicon (Rebrus p.c.), hence irrelevant to the phonology. The only exception is the suffix *-kor* '(temporal) at' which generally is taken as a clitic (cf. Kornai 1994: 68).

Having established the behaviour of the suffixes, let us turn our attention to the stems. It has been long debated whether vowel harmony is still active within the stems, as it was in earlier stages of the language. However, in this paper, I follow Kornai (1990) in denying the existence of stem-internal harmonic processes, evidence mainly coming from the increasing number of disharmonic stems (especially recent loanwords) which do not undergo any harmonic change or alternation. Hence, stem-internal harmony is best regarded as a generalisation or a violable Morpheme Structure Condition.

Finally, let me give a classification of stems, following Nádasy & Siptár (1994). As it will turn out from the examples below, Hungarian has neutral vowels with respect to palatal harmony, namely *i*, *í* {**I**}; *é* {**A.I**}.<sup>6</sup> The harmonic properties of a stem generally depend on the last non-neutral vowel, hence the classification will depend on the last vowel of the stem: we differentiate between Harmonic (**I**) and Neutral (**II**) stems. Another factor is the complexity of the stem: those stems that contain 'matching' vowels, i.e.

<sup>6</sup> The status of *e* is debated, since, as it was pointed out to me by Péter Rebrus (p.c.) (cf. Kornai (1994: 69), Ringen (1980), Vago (1980a,b) as well), it behaves ambiguously: it is sometimes harmonic (i), and sometimes speakers hesitate whether to use front or back suffixes after it (ii):

- (i) *József* + *ből<sub>ς</sub>\*ból* 'of Joseph'
- (ii) *Ágnes* + *ből<sub>ς</sub>ból* 'of Ágnes'

Nevertheless, a thorough examination of the behaviour of *e* is beyond the scope of this paper; I treat it here as harmonic.



**IIA-b Simple Neutral Back (antiharmonic)**

<i>híd</i>	‘bridge’	<i>híd+nak</i>	<i>híd+ból</i>
<i>cél</i>	‘aim’	<i>cél+nak</i>	<i>cél+ból</i>
<i>derék</i>	‘waist’	<i>derék+nak</i>	<i>derék+ból</i>

**IIB-f Complex Neutral Front**

<i>rövid</i>	‘short’	<i>rövid+nek</i>	<i>rövid+ból</i>
<i>örmény</i>	‘Armenian’	<i>örmény+nek</i>	<i>örmény+ból</i>

**IIB-b Complex Neutral Back**

<i>papír</i>	‘paper’	<i>papír+nak</i>	<i>papír+ból</i>
<i>taxi</i>	‘taxi’	<i>taxi+nak</i>	<i>taxi+ból</i>
<i>dózis</i>	‘dose’	<i>dózis+nak</i>	<i>dózis+ból</i>

**3 The analysis**

Before venturing into the analysis of Hungarian palatal harmony, let me summarise some insights which will lead us in our argumentation.

**(8) Characteristics of Hungarian vowel harmony**

- (i) Hungarian has **I** (palatal) harmony.
- (ii) Only vowels (nuclei) participate in harmonic processes.<sup>7</sup>
- (iii) Harmony does not operate stem-internally.
- (iv) Neutral vowels are **I**-headed (*i, í, é*).
- (v) Generally, the ultimate source for harmony is an **operator I** element (except for stems in **IIA-f**).
- (vi) The harmonic characteristics of a stem are usually determined by the last non-neutral vowel.
- (vii) The vowel of an unchanging suffix is generally a neutral one.

Examining the stems in classes **IA-f** and **b**, as well as taking (8i) and (8ii) into consideration, we can conclude that the process of vowel harmony takes place at the level of **Nuclear Projection**, from left to right, via **government**: a nucleus governs the following one and shares its **I** element (if it

<sup>7</sup> This is not a universal principle, cf. Turkish where palatalised (and velarised) consonants are reported to start a new harmonic domain (Kenstowicz 1994: 471). However, Hungarian lacks palatalised consonants, though palatals do exist.

has any) with its governee, or adopting Charette & Göksel's (1996) term, it "licenses itself" into the subsequent nuclear position. This can be stated as in (9):

(9) **HARMONY I (Preliminary version)**

The governor shares its **I** element (if it has any) with its governee.

This process, an element licensing itself into a governed position is not at all unfamiliar within GP: the same process is claimed to apply in cases like long nuclei, geminates, assimilation, etc. (cf. Kaye et al. 1990, Harris 1990).

From this analysis it follows that the alternating suffixes are represented with their back alternants in the Lexicon (e.g.  $b\{\mathbf{A.}\}n$ ,  $n\{\mathbf{A.}\}k$ ,  $b\{\mathbf{A.}\underline{\mathbf{U}}\}:l$ ):

(10) **HARMONY II (Representation)**

Alternating suffixes are represented with their back alternants in the Lexicon.

Principles (9) and (10) correctly account for the behaviour of stems in classes **IA-f** and **IA-b**.

**IA-f** ( $t\acute{u}z$ ):

The final harmonic front vowel ( $\acute{u}$   $\{\mathbf{I.}\underline{\mathbf{U}}\}$  in the present case) has an (operator) **I** element. Consequently, it licenses itself into the suffixal nuclear position, thus the stem selects a front suffix:



garian stem-internal harmony is no longer active (8iii). Note, however, that this is not an unknown phenomenon: we have to face the same problem whenever we deal with processes which do not take place in underived environments, i.e. stem-internally (cf. the Strict Cycle Condition in Lexical Phonology, e.g. Kiparsky 1984). These phenomena are handled within GP with the aid of the Projection Principle, as formulated by Kaye et al. (1990: 221):

(13) **Projection Principle**

Governing relations are defined at the level of lexical representation and remain constant throughout a phonological derivation.

This means, in the present case, that we have to state that (lexically) no governing relation holds between nuclei in a stem in Hungarian. This cannot be altered during the derivation, hence harmony cannot take place stem-internally. On the other hand, the stem-final (or rather domain-final) full nucleus governs the suffixal one.

Now, the case of stems in classes **IB-b** is straightforward. There is no stem-internal government, consequently the **I** element of the front harmonic vowel *ü* in *nüansz* cannot license itself into the back harmonic vowel *a*, hence, this time, we get the correct surface form: *nüansz**nak*. On the other hand, the case of **IB-f** (*sofőr*) is even more simple: the final nucleus contains the **I** element, which licenses itself into the governed nucleus, i.e. the suffixal one. Thus, the stem takes the front suffix.

So far, we have managed to understand the behaviour of harmonic stems (class **I**). However, the analysis cannot account for the behaviour of neutral stems. It suggests that neutral stems always take front suffixes, which is not at all true (cf. class **IIB-b**). Taking (8v) into consideration, we could modify principle (9) as:

(14) **HARMONY I (Revised)**

The governor shares its **operator I** element (if it has any) with its governee.

Nevertheless, this would result in neutral stems uniformly taking a back suffix, which is, again, untenable. The problem is that this analysis still regards the stem-final nucleus as the only source of harmonic processes. This is the point where we have move forward.

The GP analysis suggested in Section 1 overcomes the problem by claiming that, in the case of neutral stems, it is the **l** element of the **harmonic vowel** which spreads on the suffixal vowel. However, we can take another point of view, claiming that, in fact, the **l** element of the **neutral vowel** spreads, or to put it in a more appropriate way: it is always the **l** element of the **final nucleus** (the governor in the present analysis) which licenses itself into the governed position. The only thing we should clarify is what can restrain spreading in the case of stems **IIB-b**. Or, to regard matters from the opposite view, what can allow or support the spreading of the **l** element of the final neutral vowel in class **IIB-f**? To handle the situation, let me introduce a new tool, called Harmonic licensing (H-licensing; different from h-licensing which stands for head-licensing, cf. Walker 1995). Only the **l** element of a H-licensed nucleus can license itself into the governed nucleus. The fact that harmonic vowels always spread their **l** element motivates the postulate that harmonic vowels are always H-licensed. Hence, we have the final version of principle (9):

(15) **HARMONY I (Final version)**

The **l** element of the H-licensed governor licenses itself into the governed position.

A further principle describes H-licensed elements, i.e. defines neutrality:

(16) **HARMONY III (Harmonic segments)**

All nuclei are H-licensed inherently, except for the **l**-headed ones.

Finally, we have to clarify what H-licensors can be. For this let us examine class **IIB**.

**IIB-f** (*rövid*):

These stems take front suffixes and their final non-neutral vowel is front harmonic ( $\ddot{o}$  {**Al.U**} in this case), i.e. it contains an **l** element in operator position. This **l** element must be able to give H-licence to the final neutral nucleus, which thus can share its **l** element with its governee, the suffixal vowel. Hence operator **l** elements must be H-licensors.

(17) The case of class IIB-f

IIB-f *rövid+nek*

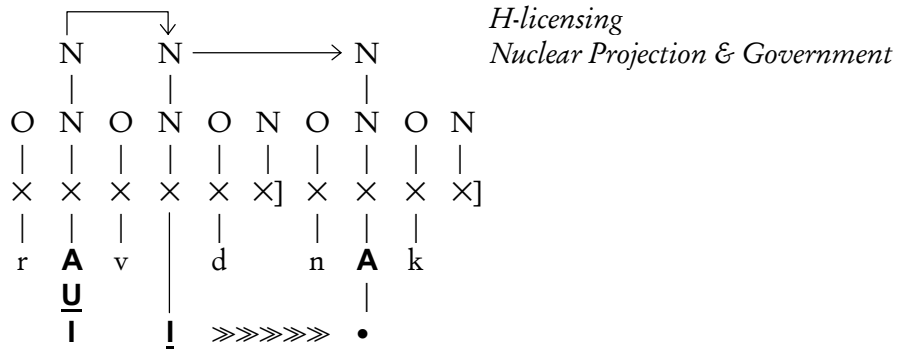

IIB-b (*papír*):

This problematic case is also handled correctly with the present analysis: the penultimate nucleus (*a* {**A**.}) does not contain any **I** elements, thus it cannot H-license the following neutral vowel, hence it cannot license its head-**I** element into the suffixal nuclear position, and the stem, as a consequence, selects a back alternant:

(18) The case of class IIB-b

IIB-b *papír+nak*

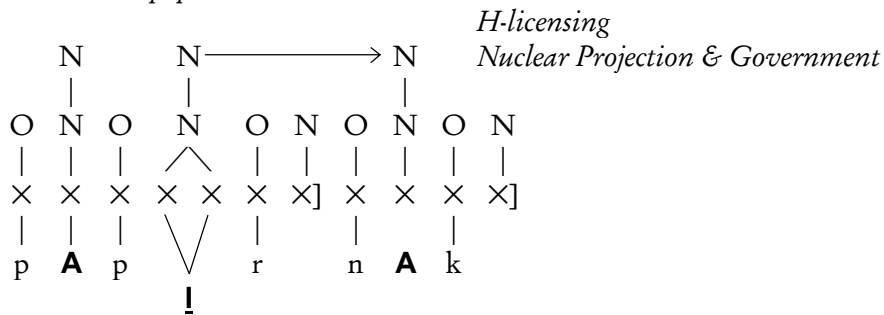

So far, we can claim that H-licensors are operator **I** elements. However, let us examine another problematic case, class **IIA-f** (*víznek*).

**IIA-f** (*víz*):

The neutral nucleus, being the only one within the stem, cannot be H-licensed, hence it cannot share its head-**I** element with the suffixal vowel,

consequently the stem takes the back alternant of the suffix. Nevertheless, we can observe just the opposite thing, these stems select front alternants. How can we explain these facts?

Examine what we have here: the neutral vowel gets its H-licence, although it is the only vowel in the stem (or to be more exact, there only neutral vowels in the stem). In GP terminology this vowel is called the head of the word. (I assume that the head of the word is the **first full** nucleus – this correlates with Hungarian stress patterns as well.) However, in GP, this phenomenon is subject to another principle, the Licensing Principle (Kaye 1990: 306; cf. Harris 1992, as well):

(19) **Licensing Principle** (Kaye 1990: 306)

All phonological positions save one must be licensed within a domain. The unlicensed position is the head of the domain.

This we could modify a bit, either saying that the head of the domain (presumably of the **word**) has (all kinds of) licence inherently, or saying that the head is licensed by an external licenser – the decision between the two alternatives is beyond the scope of this paper, further research is needed. For our future investigation, both alternatives are satisfactory:

(20) **HEAD-LICENSING**

The head nucleus of the stem is externally inherently licensed to govern.

Hence, the principle defining H-licensors is:

(21) **HARMONY IV (H-licensors)**

Internal H-licensors are nuclei containing an **l** element in operator position. The head of the domain (word) is externally H-licensed. H-licensing is strictly local (at the level of Nuclear Projection, presumably) and left to right.

Let us return to the class **IIA-f** (*víz*). The analysis is now straightforward: the neutral vowel being the head of the domain (i.e. stemword) is H-licensed, hence it shares its **l** element with the suffixal nucleus, and so the stem selects the front alternant:

(22) The case of class IIA-f

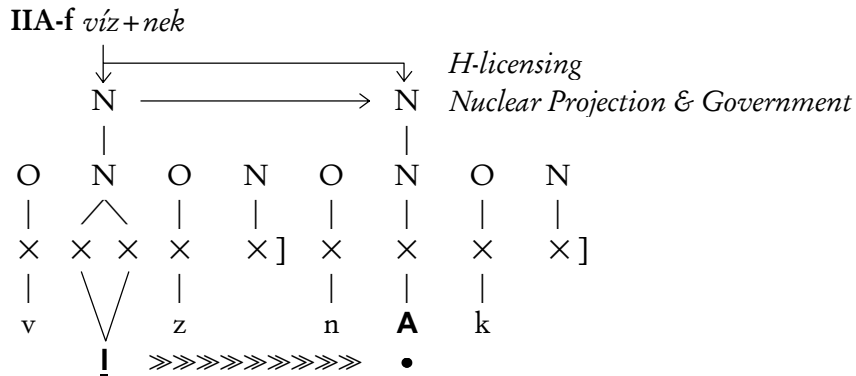

So far, we have examined and accounted for the behaviour of all but one class set up in Section 3. The remaining class is **IIA-b** (*híd*). Note, however, that this is a closed class in Hungarian, containing only a handful words; the process is not at all productive. Briefly, these stems are clearly irregular, no longer subject to the phonological processes mentioned above. Hence, it is better to refer this phenomenon to the lexicon, instead of phonology.<sup>9</sup>

Finally, let me summarise the principles describing harmonic processes in Hungarian. In the next section, we shall turn to two other interesting phenomena, which further support the present treatment of harmony; namely, the cases of vacillating stems and multiple suffixation.

(23) The principles of Hungarian vowel harmony

HARMONY I

The **I** element of the H-licensed governor licenses itself into the governed position.

HARMONY II

Alternating suffixes are represented with their back alternants within the Lexicon.

<sup>9</sup> Note that e.g. in Vago (1980a), these stems were analysed as having an abstract high, back, unrounded vowel, which never surfaces (and which most of these stems used to have historically). This analysis is untenable within GP since the theory does not recognise abstract segments. Nevertheless, we may say that the irregularity of these stems is marked by the fact that their heads exceptionally cannot be externally H-licensed, thus they select back alternants.

HARMONY III

All nuclei are H-licensed inherently, except for the **I**-headed ones.

HARMONY IV

Internal H-licensors are nuclei containing an **I** element in operator position. The head of the domain (word) is externally H-licensed. H-licensing is strictly local (at the level of Nuclear Projection) and left to right.

4 Further consequences

4.1 Vacillating stems

First of all, our analysis needs a little revision: in the **II-f** class, we can find stems containing two or more neutral nuclei (e.g. *bili* ‘potty’, *bicikli* ‘bicycle’), selecting front suffixes. Let us examine what our analysis would predict: the final *i* {**I**} of the stem, which is not the head of the domain, is not H-licensed, the only licensor being an operator **I**, which is not present. Hence, the stem should select a back alternant, which it does not:

(24) Polysyllabic IIA-f stems, incorrect analysis

IIA-f \**bili+nak*

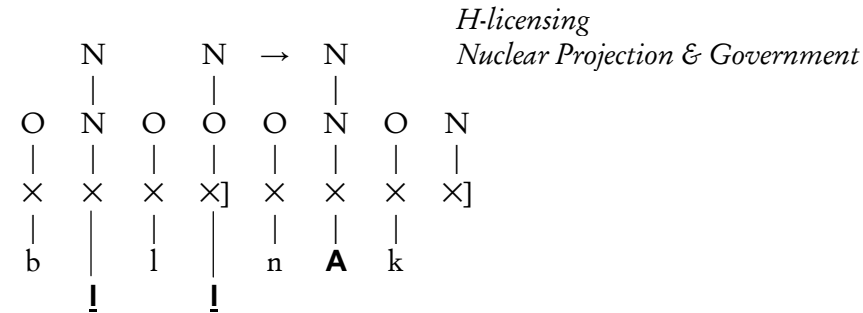

Note, however, that the previous nucleus contains an **I** element, though not in operator position. Hence, the only thing we have to do is alter our principle (21):

(25) HARMONY IV (Revised)

(Internal) H-licensors are **I** elements.



Note, furthermore, that (27b) is more marked than (27a), which suggests that the back suffixation is less frequent with vacillating stems than the front one. This claim is indeed supported by Ringen & Kontra (1989), who report that speakers usually use the front suffix with the majority of vacillating stems. Nevertheless, we have to admit that there are some exceptions. However, this situation might have non-linguistic reasons.

#### 4.2 Multiple suffixation

Since Hungarian is an agglutinating language, stems are subject to multiple suffixation, as it is shown below:

(28) Examples of multiple suffixation

- ház+unk+nak* ‘house+POSS. 1st Pl.+DATIVE’ ‘for our house’
- kör+ünk+nek* ‘circle+POSS. 1st Pl.+DATIVE’ ‘for our circle’

Our analysis predicts the correct results here. If the stem-final nucleus is back or not H-licensed neutral, it cannot share the **I** element with the following nucleus, which, thus, surfaces without **I**. Consequently, the latter does not have anything to share with the following suffix and both (all) suffixes are back:

(29) Multiple suffixation of stems in IA-b

IA-b *ház+unk+nak*

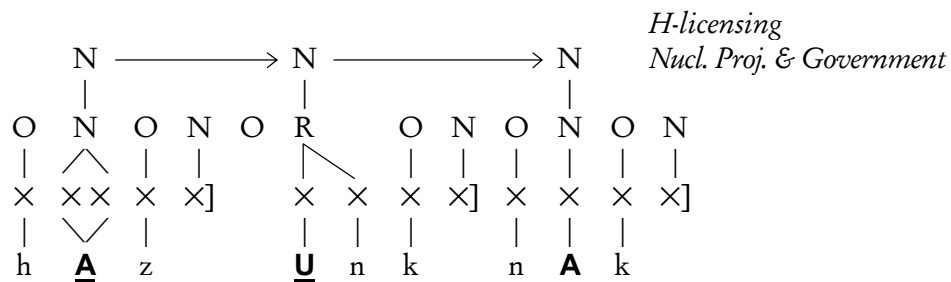

On the other hand, suppose that the stem-final nucleus is harmonic front. Then, its operator **I** element can license itself into the suffixal nucleus, which is now H-licensed as well and contains an **I** element, hence it shares the **I** with the vowel of the next suffix (and so on). So, both (all) suffixes are front:

(30) Multiple suffixation of stems in class IA-f

IA-f *kör+ünk+nek*

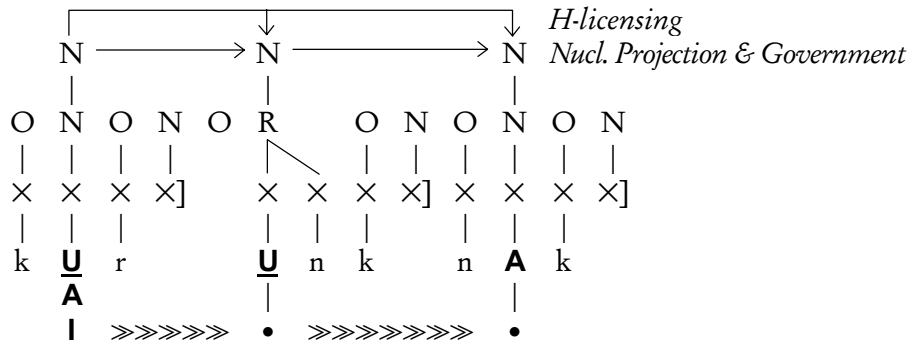

Note that in this case, H-licensing is not necessary between the nuclei. Nevertheless, for the sake of simplicity and symmetry, I assume that this relationship holds in this case as well. Furthermore, I claim that the same relationship exists within the stem and the suffix (cf. previous subsection), as well as between the stem-vowel and the suffixal vowel.

Finally, consider the case of a stem ending in a H-licensed neutral vowel, such as *örmény* ‘Armenian’. Here, the stem-final nucleus is H-licensed; therefore, it licenses its head-I into the operator position of the first suffixal vowel, which is, then, H-licensed. Hence, it shares this I element with the next suffix, and so on. Consequently, all suffixes are front.

(31) Multiple suffixation of stems in class IIB-f

IA-f *örmény+ünk+nek*

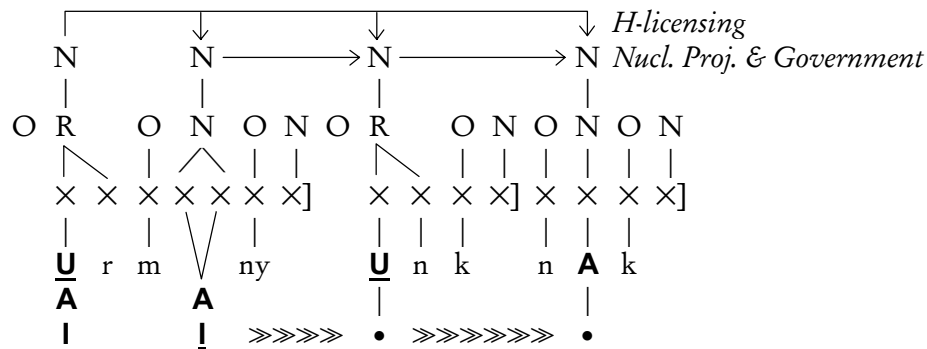





- (35) Neutral segments in a harmonic system are the ones which lack inherent H-licence.

This treatment, however, suggests that across languages any segment can be neutral, neutrality being an arbitrary characteristics of a given segment. This seems to be quite an overgeneralisation, thus we should find a way of restricting the theory.

In (8iv), as well as in HARMONY III, I state that harmonically neutral vowels in Hungarian are those that are the **I**-headed (which, as a matter of fact, need an H-licence so as to share their **I** elements with their governees). This assumption might well be a candidate for the following generalisation:

(36) **Neutrality**

Neutral segments with respect to the harmony of the element **X** are the ones which are headed by the same **X** element.

This is promising, but unfortunately not generally true. Harris (1994) analyses the height harmony system of Chicheŵa within basically the same framework. In this language, height harmony is derived by the spreading of the element **A**, whenever it is in operator position. **A**-headed vowels, instead of being neutral, are opaque, due to the No Switching constraint (regardless of how Harris formalised this), which does not allow an element to spread from a head position into an operator position (and vice versa). Note, however, that regarding non-harmonic (i.e. neutral and opaque) effects as a consequence of this constraint is generally untenable: in Hungarian, the governing **I** can “spread” from operator position (i.e. from a harmonic vowel) to head position (cf. the alternation between *á* {**A**} and *é* {**A.I**} in the adessive suffix *nálgnél* ((6) in Section 2). Otherwise we should assume different representations of the same vowel when it is not in the stem but in an alternating suffix. Namely, I mean the case of *é* here: {**A.I**} in the stem or a non-alternating suffix and {**AI**.} – which is unfortunately the representation of *e* [ɛ] as well – in an alternating one.

Note, however, that Chicheŵa does not have transparent vowels. Thus, we can refine (36) as (37):

(37) **Neutrality**

If the harmonic system with respect to the element **X** contains neutral vowels, these vowels are always headed by the **X** element.

Furthermore, the vowels containing an **X** element in operator position always behave in the same way: they are universally harmonic:

(38) **Neutrality**

In a harmonic system where the **X** element “spreads”, the vowels containing the element **X** in their operator position are truly **harmonic**.

The reason might well be that elements in operator position are attached to the segment less tightly than its head, which is regarded as its “spine”, only “coloured” by the operator elements. Consequently, operator elements take part in harmonic processes more readily; they need less support to license themselves into the governed position than the head elements.<sup>12</sup>

Now, let us turn to the status of **X**-headed segments. I suggest that their behaviour is subject to parametric variation across languages, hence a possible basis for the typology of harmonic systems:

(39) **Typology I**

- (i) they might simply be **opaque** segments, unable to license their head-**X** elements into the governed position: the case of Chicheŵa;
- (ii) they might be able to “spread” their **X** element but only with a licence, i.e. they act as **neutral** segments in the harmonic system: this possibility incarnated in Hungarian;
- (iii) they can be truly **harmonic**, always sharing the harmonic element with their governee. This option is observable e.g. in Turkish (cf. Charette & Göksel 1996).

Note that in the cases (i) and (iii), the system does not contain neutral vowels.

Finally, the behaviour of segments lacking the **X** element is open. In my opinion, these segments can be

---

<sup>12</sup> This would suggest that phonological processes (e.g. lenition) affect operator elements more often than heads. I do not know whether this is the case, further research in this field is indispensable.

(40) **Typology II**

- (i) **opaque** if they do not have a harmonic counterpart, i.e. a segment containing the **X** element. This option is incarnated in, for example, Wolof (Kenstowicz 1994: 355–359) where *a* lacks a [+ATR] counterpart;
- (ii) they might be able to “spread” their **X** element but only with a licence, i.e. they act as **neutral** segments in the harmonic system: this possibility incarnated in Hungarian;
- (iii) they can be truly **harmonic**, always sharing the harmonic element with their governee. This option is observable e.g. in Turkish (cf. Charette & Göksel 1996).

**5.2 On harmony and H-licensing**

Our analysis outlined in Section 3 heavily depended on a newly invented notion: H-licensing. This tool formalises the observation that the behaviour of a segment (a neutral nucleus in the present case) depends on the previous one. However, this seems to be our invention solely in order to overcome the problems raised by neutral vowels. Or is there any support for introducing this new tool?

Let us articulate what this H-licensing expresses in the broadest sense: there are two segments in some kind of relationship, presumably in head-dependent (or licensor–licensed) status. Certain characteristics of the head enable the dependent to express its related characteristic feature (i.e. the head containing an **I** element empowers the dependent to license its **I** element into the next nuclear position). However, this phenomenon is not at all unknown in the GP framework. Charette (1990) introduces basically the same tool, called “government-licensing”. The governing nucleus can allow its onset to govern a complement; if the nucleus is empty, this might fail, hence the consonant cluster simplifies. Furthermore, Yoshida (1992) (quoted in Kaye 1995) claims the same principle to be active in the case of closed syllable shortening; this time between nuclei.

Moreover, recall the unification of autosegmental and prosodic licensing in Harris (1992). There, government licensing is claimed to be a straightforward consequence of the Licensing Inheritance principle: the onset inherits the governing properties of its governor. If the governor is an empty nucleus, it has little licensing power, hence its complement cannot have further complements. This process is definitely the same as the phenomenon exhib-

ited by vowel harmony. Finally, note that the above mentioned unification opened a gap within the system: prosodic government-licensing lacks an autosegmental counterpart. This gap is now filled by the autosegmental H-licensing, which, together with government-licensing, deserves to be called **extended g-licensing**.

By this time, it is clear why **l**-headed segments are neutral whereas segments containing the **l** element in operator position are always harmonic: the operator element is more mobile hence it needs less licensing power to license itself into the following nuclear projection. On the other hand, the head element is more strictly attached to the segment itself, hence it needs more licensing power in order to associate itself with the governed position. As a consequence, we managed to get rid of the uncomfortable notion of H-licensing as well (though I will go on using it as a shorthand – the same way as “coda” is used). The neutral (any) vowel inherits the (**l**) licensing potential of the previous nucleus. If the latter licenses (i.e. contains) an **l** element, the former has (inherits) enough power to license its (head) **l** element into the next nuclear position. Hence, vowel harmony, without further stipulation, is a straightforward consequence of the Licensing Inheritance principle.

Finally, as a further support to our analysis, recall that stress is generally associated by the same licensing we rely on here. Thus, as a consequence, one would expect a certain interaction between stress and vowel harmony. Indeed, L. B. Anderson (1980) reports such a case in Finnish. Furthermore, Ringen & Kontra state that

“when *e* or *é* is preceded by a *stressed* back vowel (as they are in disyllabic mixed roots) suffixes are more likely to have back vowels than when *e* or *é* is preceded by an *unstressed* back vowel” (1989: 190).

This indeed is in accord with the assumptions of this analysis.

### 5.3 Labial versus palatal harmony

In this paper, I have treated Hungarian palatal harmony as the typical, and fundamentally the only kind of, harmonic process. However, Hungarian has labial (in GP terms, **U**) harmony, as illustrated below, which is essentially different from the former. The examples show the behaviour of the ternary allative suffix: *-hoz* *-hez* *-höz*, which is back after stems taking back suffixes, while in the case of front stems, the suffixal vowel agrees in

rounding with the stem-final nucleus (examples from Polgárdi & Rebrus 1996: 6):

(41) **Hungarian labial harmony**

<i>bab</i>	<i>bab+hoz</i>	‘to the bean’
<i>ház</i>	<i>ház+hoz</i>	‘to the house’
<i>kút</i>	<i>kút+hoz</i>	‘to the well’
<i>bot</i>	<i>bot+hoz</i>	‘to the stick’
<i>víz</i>	<i>víz+hez</i>	‘to the water’
<i>érv</i>	<i>érv+hez</i>	‘to the argument’
<i>tök</i>	<i>tök+höz</i>	‘to the pumpkin’
<i>füst</i>	<i>füst+höz</i>	‘to the smoke’

Polgárdi & Rebrus (1996) analyse this kind of harmony as basically different from what we have in the case of palatal harmony. They claim that labial harmony is best regarded as a licensing, instead of a spreading-governance phenomenon:

(42) **Labial Harmony**

**A, I and U** in a governed position are only licensed by a governing **I** and **U**. (Polgárdi & Rebrus 1996: 8)

The different treatment of the two kinds of harmonic processes is well justified by the facts that

- (i) labial harmony in Hungarian is very restricted, it only applies for suffixes containing short mid-vowels (*o* *e* *ö*), whereas every vowel participates (in one way or another) in palatal harmony;
- (ii) there are no transparent segments with respect to labial harmony, while this does not hold for palatal harmony.

The process clearly is an instance of “reduction harmony” (cf. Harris 1994: 541, fn.9). This leaves us with at least two fundamentally different kinds of harmonic process (“h-licensing” being a third candidate, cf. Walker 1995). Note, however, that our analysis of neutrality would run the same way in the case of reduction harmony, supporting the claim of it being universal.

## 6 Summary

In this paper I presented a treatment, which I claimed to be universal, of vowel harmony and neutral (transparent) segments within harmonic systems. The analysis was based on the notion of Harmonic licensing, which was later regarded as the straightforward consequence of the Licensing Inheritance principle. I justified my proposal by a thorough analysis of Hungarian palatal harmony, which can be accounted for by the following principles:

### (43) The principles of Hungarian vowel harmony

#### HARMONY I

The **I** element of the H-licensed governor licenses itself into the governed position.

#### HARMONY II (Representation)

Alternating suffixes are represented with their back alternants within the Lexicon.

#### HARMONY III

All nuclei are H-licensed inherently, except for the **I**-headed ones.

#### HARMONY IV (H-licensors)

Internal H-licensors are nuclei containing an (H-licensed)\* **I** element in operator position (\* is an option varying from speaker to speaker). The head of the domain (word) is externally H-licensed. H-licensing is strictly local (at the level of Nuclear Projection) and left to right.

Finally, I proposed a possible typology of harmonic languages depending on the behaviour of the segments headed by the harmonic element.

## References

- Anderson, L. B. (1980) 'Using asymmetrical and gradient data in the study of vowel harmony'. In Vago 1980c: 271–340.
- Anderson, Stephen R. (1980) 'Problems and perspectives in the description of vowel harmony'. In Vago 1980c: 1–48.
- Borowsky, Toni (1986) 'Topics in the Lexical Phonology of English'. Ph.D. dissertation. Amherst: University of Massachusetts. Published by Garland Press, New York, 1990.

- Charette, Monik (1990) 'Licence to govern'. *Phonology* 7. 233–253.
- Charette, Monik and Aslı Göksel (1996) 'Licensing constraints and vowel harmony in Turkic languages'. *SOAS Working Papers in Linguistics and Phonetics* 6. 1–25.
- Dunn, Christian (1992) 'Aspects du gouvernement harmonique'. Ph.D. dissertation. Montréal: Université du Québec.
- Goldsmith, John A. (1985) 'Vowel harmony in Khalka Mongolian, Yaka, Finnish and Hungarian'. *Phonology Yearbook* 2. 253–275.
- Goldsmith, John A., ed. (1995) *The Handbook of Phonological Theory*. Cambridge, Mass. & Oxford: Blackwell.
- Harris, John (1990) 'Segmental complexity and phonological government'. *Phonology* 7. 255–300.
- Harris, John (1992) 'Licensing inheritance'. *UCL Working Papers in Linguistics* 4. 359–406.
- Harris, John (1994) 'Monovalency and opacity: Chicheŵa height harmony'. *UCL Working Papers in Linguistics* 6. 509–549.
- van der Hulst, Harry (1985) 'Vowel harmony in Hungarian: a comparison of segmental and autosegmental analyses'. In Harry van der Hulst and Norval Smith, eds. (1985) *Advances in Nonlinear Phonology*. Dordrecht: Foris. 267–303.
- van der Hulst, Harry and Jeroen van de Weijer (1995) 'Vowel harmony'. In Goldsmith 1995: 495–534.
- Kaye, Jonathan (1990) "'Coda" licensing'. *Phonology* 7. 301–330.
- Kaye, Jonathan (1995) 'Derivations and interfaces'. In Jacques Durand and Francis Katamba, eds. (1995) *Frontiers of Phonology*. Harlow: Longman. 289–332.
- Kaye, Jonathan, Jean Lowenstamm and Jean-Roger Vergnaud (1985) 'The internal structure of phonological elements: a theory of charm and government'. *Phonology Yearbook* 2. 305–328.
- Kaye, Jonathan, Jean Lowenstamm and Jean-Roger Vergnaud (1990) 'Constituent structure and government in phonology'. *Phonology* 7. 193–231.
- Kenstowicz, Michael (1994) *Phonology in Generative Grammar*. Cambridge, Mass. & Oxford: Blackwell.
- Kornai, András (1990) 'Hungarian vowel harmony'. In István Kenesei, ed. (1990) *Approaches to Hungarian, Volume Three: Structures and Arguments*. Szeged: JATE. 183–240.
- Kornai, András (1994) 'On Hungarian morphology'. *Linguistica, Studia at Dissertationes* 14. Budapest: A Magyar Tudományos Akadémia Nyelvtudományi Intézete.
- Kiparsky, Paul (1984) 'On the lexical phonology of Icelandic'. C. Elert, I. Johansson and E. Strangert, eds. (1984) *Nordic Phonology III*. Stockholm: Almqvist & Wiksell. 135–64.

- Nádasdy, Ádám and Péter Siptár (1994) 'A magánhangzók [Vowels]'. In Kiefer Ferenc, ed. (1994) *Strukturális magyar nyelvtan 2. Fonológia. [A Structural Grammar of Hungarian 2. Phonology.]* Budapest: Akadémiai Kiadó. 42–182.
- Polgárdi, Krisztina and Péter Rebrus (1996) 'There is no labial harmony in Hungarian: a Government Phonology analysis'. *Working Papers in Linguistics* 3. No. 3. Budapest: Research Institute for Linguistics, Hungarian Academy of Sciences.
- Ringen, Catherine O. (1980) 'A concrete analysis of Hungarian vowel harmony'. In Vago 1980c: 135–154.
- Ringen, Catherine O. (1988) 'Transparency in Hungarian vowel harmony'. *Phonology* 5. 327–342.
- Ringen, Catherine O. and Miklós Kontra (1989) 'Hungarian neutral vowels'. *Lingua* 78. 181–191.
- Ritter, Nancy Ann (1995) 'The role of Universal Grammar in phonology: a Government Phonology approach to Hungarian'. PhD dissertation. New York University.
- Vago, Robert (1980a) *The Sound Pattern of Hungarian*. Washington: Georgetown University Press.
- Vago, Robert (1980b) 'A critique of suprasegmental theories of vowel harmony'. In Vago 1990c: 155–181.
- Vago, Robert, ed. (1980c) *Issues in Vowel Harmony*. Amsterdam: John Benjamins B.V.
- Walker, Caitlin (1995) 'Atr-harmony as h-licensing'. *SOAS Working Papers in Linguistics and Phonetics* 5. 107–121.
- Yoshida, Shohei (1992) 'Licensing of governing nuclear heads'. *Proceedings of the Krems Government Phonology Workshop*.