

- Schachter, Paul. 1985. Parts-of-speech systems. In *Language typology and syntactic description*, Vol. 1: *Clause structure*, ed. Timothy Shopen, 3-61. Bath: Cambridge University Press.
- Shibatani, Masayoshi, ed. 1976. *Syntax and semantics 6: The grammar of causative constructions*. New York: Academic Press.
- Thompson, Laurence 1979. The control system: A major category in the grammar of Salishan languages. In *The Victoria Conference on Northwestern Languages*, ed. Barbara Efrat, 156-176. Victoria: British Columbia Provincial Museum.
- Trask, R.L. 1993. *A dictionary of grammatical terms in linguistics*. London: Routledge.
- Tuggy, David. 1988. Náhuatl causative/applicatives in cognitive grammar. In *Topics in cognitive linguistics*, ed. Brygida Rudzka-Ostyn, 587-618. Amsterdam: John Benjamins.
- van Oosten, Jeanne. 1977. Subjects and agenthood in English. In *Papers from the Thirteenth Regional Meeting of the Chicago Linguistic Society*, ed. Woodford Beach, Samuel E. Fox, and Shulamith Philosopher, 459-471. Chicago Linguistic Society, University of Chicago.

Implications of Consonant Nasalization for a Theory of Harmony

G.L. PIGGOTT
McGill University

1. INTRODUCTION

At the level of observation, harmony is a phonological pattern in which segments (the targets) have the same feature specification as a segment (the trigger) to their left and/or right. Conventional phonological analyses consider these to be patterns of assimilation in which one segment acquires part of its identity from another segment. Most analyses subscribe to the thesis that the segments involved in the assimilation must be adjacent on some well-defined tier (Archangeli and Pulleyblank 1987; Odden 1994). This locality requirement can be expressed as follows (cf. Steriade 1995:121):

(1) *The Locality Condition*

The elements related by a phonological rule or constraint must be adjacent on some tier.

Superficially, many cases of harmony appear to violate locality because the harmonizing segments are not adjacent. Most of the apparent violations are dealt with by defining adjacency either at the level of a prosodic position or at a subsegmental level involving the node which anchors the harmonic feature. Both possibilities have been applied to the analysis of vowel harmonies. For Archangeli and Pulleyblank (1994), locality holds at the syllable-internal level of the moraic positions, the equivalent of the nucleus in a constituent-based description of syllable structure, while the feature geometry of Clements and Hume (1995) defines vowel adjacency at the level of V-Place nodes. The cases of consonant harmony

Research for this article was supported by a grant from the Social Sciences and Humanities Research Council of Canada (410-92-0759). The central ideas emerged while the author was a Visiting Scholar at the Holland Institute of Generative Linguistics, Leiden University. Comments and suggestions by Harry van der Hulst and other members of the Leiden linguistic community are gratefully acknowledged. The article also benefited from critical evaluation by Isabel Fonte, Suzy Fukuda, Heather Goad, Janet Grijzenhout, Takako Kawasaki, Martine Kessler-Robb, Charles Reiss, and Yvan Rose.

discussed by Shaw (1991) require locality to be defined at a subsegmental level, when coronal consonants in a word must agree for coronal features.

The two ways of defining adjacency are sometimes presented as rule-specific options (Archangeli and Pulleyblank 1987). Goad (1993) exploits this possibility to account for the difference in the effect of neutral vowels on harmony in Yoruba and Wolof. In the former, where adjacency applies at the level of the syllable-internal position, the harmonically neutral vowels /i, u/ block a pattern described as Low harmony. In the latter (Wolof), the equivalent vowels are transparent to a similar Low harmony, because adjacency is considered to hold between segment-internal nodes which are not part of the structure of high vowels.

Phonologists have clearly made considerable effort to maintain a restrictive theory in which some version of the Locality Condition is a fundamental principle. Nevertheless, in spite of the development of fairly rich models of segment structure, the problem of segment transparency in harmony systems has not been completely solved. One case that seems to be intractable in current approaches is represented by consonant nasalization in a number of Bantu languages. At the level of observation, a nasal consonant in a root triggers the nasalization of a lateral consonant in a suffix, but vowels are unaffected by the process. Hyman (1994) provides an extensive list of languages manifesting this pattern; it includes Bemba, Lamba, Tonga, Luba, Suku, Yaka, and Kongo (= Kikongo).

There are really two patterns of consonant nasalization. In Kikongo and Yaka, the trigger and target can be separated by any number of consonants, provided that these are obstruents or nasal contours (i.e., prenasalized consonants). The data in (2a) show that the endings /-ulu/ and /-ila/ contain a liquid when they follow roots lacking nasal consonants, while the corresponding endings in (2b-c) contain nasals when the roots contain nasals.

(2) *The Kikongo Pattern*

- | | | |
|----|----------------|------------------------|
| a. | ma-bul-ulu | 'it was hit' |
| | sakid-ila | 'to congratulate for' |
| b. | ma-kin-unu | 'it was planted' |
| | wu-mant-umu | 'it was climbed' |
| c. | kudumuk-is-ina | 'to cause to jump for' |
| | mant-ina | 'to climb for' |

In the stem *kudumukisina*, the trigger is in the third syllable and the target in the sixth (and final) syllable. A different pattern occurs in Lamba. Consonant nasalization in this language is also initiated by a root nasal, but the trigger and target must be in adjacent syllables:

(3) *The Lamba Pattern*

- | | | |
|----|----------------|------------------|
| a. | paṭa | 'scold' |
| | paṭ-ile | 'scolded (PERF)' |
| b. | uma | 'dry' |
| | um-ine/*um-ile | 'dry (PERF)' |

PIGGOTT

- | | | |
|----|------------------|------------------|
| c. | masa | 'plaster' |
| | mas-ile/*mas-ine | 'plaster (PERF)' |

The alternation in the perfective suffix confirms the occurrence of consonant nasalization, but the nasal at the beginning of the stem *masile* does not affect the lateral in the third syllable.

Given our current understanding of suprasegmental and segmental structures, the two consonant nasalization patterns are problematic for a locality condition like that in (1), because there is no level at which the trigger and target can be defined as adjacent segments. While the skipping of vowels in both patterns is difficult to explain, an even greater challenge is presented by the skipping of syllables in the Kikongo pattern. The target and segments are in adjacent syllables in Lamba, but the equivalent segments in Kikongo are arbitrarily far apart.

The difficulty of these cases might lead one to question the hypothesis that phonological rules and constraints are governed by a locality condition (cf. Cole and Kisseberth 1994). However, there are very good reasons why the universality of such a principle must be maintained. Archangeli and Pulleyblank (1994) offer a theoretical argument based on the assumption that the relations reflected in assimilation phenomena are represented autosegmentally by multiply-linked features. They contend that a representation in which non-adjacent units on the relevant tier are linked to the same feature violates a universal Precedence Principle. This theory-internal argument can be bolstered by an empirically-based one. The Locality Condition restricts the possible ways in which assimilation can be manifested. For example, nasals often assimilate place features from a following consonant. This common pattern of assimilation must be restricted to adjacent segments. There seem to be no cases in which the place features spread from a consonant to a nasal which is not strictly string-adjacent to the source of the features. The assimilation of secondary articulations from vowels to consonants also seem to be universally subject to segment adjacency.

Given the desirability of maintaining the Locality Condition, we should try to reconcile the consonant nasalization in Lamba and Kikongo with the requirements of such a restriction. This article pursues such an objective. However, it leads to a radical re-thinking of the nature of harmony. I reject the view that harmony must necessarily be described as a relation between segments which must be adjacent at some level. Instead, I support a new conception of harmony which characterizes the phenomenon as a relation which may hold either between segments or between suprasegmental units (see also Piggott 1996; Piggott and van der Hulst 1996). I propose that Lamba nasalization is a relation between syllables. From a derivational perspective, this pattern is the result of the spreading of [nasal] from syllable to syllable. Consonant nasalization in Kikongo is considered to have a different medium of transmission. In my analysis, it follows from harmony as a relation between feet. When syllables are targets, the mere skipping of a consonant or a vowel does not produce a violation of locality but the skipping of an entire syllable would. Hence, syllables are never skipped in Lamba. In Kikongo, on the other

hand, syllables can be invisible to nasalization, because they are not targeted by the process.

I present my analysis in a framework which assumes that phonological representations must satisfy a set of constraints or wellformedness conditions on representations. The constraints are of two types. One set applies to all languages and therefore constitutes principles of Universal Grammar. Another set has variable effects on languages. There now seem to be two ways of accounting for this variability. In terms of one approach, which is well represented in both phonological and syntactic analyses, some constraints may or may not be activated on a language-particular basis. The constraints that allow such a choice are the so-called parameters of variation (Chomsky 1981). More recently, Prince and Smolensky (1993) introduce the framework of Optimality Theory which allows each language to impose an arbitrary ordering on a universal set of constraints. Variation in languages is, thereby, reduced to differences in constraint ranking. I will adopt the principles and parameters framework in this article, but this is not to be construed as a rejection of the optimality-theoretic framework. My focus is on representation rather than the interaction of constraints.

Before presenting my analysis of the consonant nasalization patterns, I review the full range of data that must be accounted for. This is followed by an overview of the fundamentals of the theory of harmony I assume. Analyses of the Lamba and Kikongo patterns as instances of harmony are provided in section 4. The concluding section contains an evaluation of more conventional analyses of long-distance consonant nasalization. Special attention is paid to proposals by Odden (1994) where the Lamba and Kikongo cases are considered to be crucial support for a locality theory that differs significantly from the one defended in this article.

2. AN OVERVIEW OF THE KIKONGO AND LAMBA PATTERNS

The Kikongo facts are taken from descriptions by Bentley (1887), Laman (1936), Ao (1991) and Odden (1994); Hyman (1994) reports similar data for Kiyaka. As pointed out in the introduction, harmony is restricted to root-suffix combinations; the morphological domain can be described as the stem. The process is triggered by a nasal consonant in the root and targets a lateral liquid to the left of the trigger; the derived or output segment is a nasal stop.¹ The harmony produces alternations in several suffixes. The following data illustrate the realization of three of these suffixes when the verb root/stem contains no nasal consonant:

- (4) a. m-bud-idi 'I hit' c. bukik-ila 'to cover by inverting'
 n-suk-idi 'I washed' sakid-ila 'to congratulate for'

¹I follow Odden (1994) in assuming that the overt target is an underlying *l*, which has the stop *d* as a variant. However, the choice of the liquid or stop as underlying does not matter, provided we represent the stop as an underlying sonorant (see Rice 1993 for such a possibility).

- b. ma-buj-ulu 'it was hit'
 ma-suk-ulu 'it was washed'

The /d/ of these suffixes is replaced by a nasal when they are affixed to roots containing a nasal:

- (5) a. tu-kin-ini 'we planted' c. kukin-ina 'to dance for'
 tu-nik-ini 'we ground' kudumuk-ina 'to jump for'
 b. ma-kin-unu 'it was planted' d. kukin-is-ina 'to cause to dance for'
 ma-nik-unu 'it was grounded' kudumuk-is-ina 'to cause to jump for'

From the data in (5), it can be deduced that a number of vowels and/or voiceless consonants may appear between the nasal in the root and the derived nasal in the suffix.

Nasal harmony in Kikongo is not triggered by every instance of a nasal consonant in a root. The lateral in a suffix never harmonizes with a nasal which is part of a nasal-obstruent sequence. Such sequences in Bantu languages are often analyzed as prenasalized consonants (Herbert 1986), and I follow that practice here, although it is not crucial to my analysis:

- (6) a. kamb-ika 'to put across' d. koj-k-a 'to shift near'
 kamb-ila 'to intercept' koj-k-ela 'to push to'
 b. somp-eka 'to lend' e. taŋ-g-a 'to count'
 somp-ela 'to borrow from/for' taŋ-g-ulula 'to re-count'
 c. bind-ika 'to lock' f. banz-uka 'to glance off'
 bind-ula 'to unlock' banz-ula 'to bounce'

The other interesting aspects of the behaviour of prenasals is that they do not block nasalization if the root contains a full nasal:

- (7) a. mant-a 'to climb' b. meŋ-g-a 'to hate'
 tu-mant-ini 'we climbed' tu-meŋ-g-ini 'we hated'

In summary, the target of nasalization in Kikongo appears to be a lateral liquid which harmonizes with a nasal in a preceding root. Secondly, only full nasals can trigger the process; the nasal component of a prenasal is inert. Thirdly, the skipped segments include vowels, voiceless obstruents and prenasalized consonants. Finally, there is no evidence that nasalization is ever blocked.

The illustrative data for the second pattern is from Lamba, but both Odden (1994) and Hyman (1994) confirm that it is found in other Bantu languages. Like the Kikongo pattern, a nasal in a root causes nasalization of a liquid in a suffix. The following information is adapted from Doke (1938) and Odden (1994):

- (8) a. nwa 'drink' nw-ine 'drink (PERF)'
 uma 'dry' um-ine 'dry (PERF)'
 mina 'swallow' min-umuna 'unswallow'
 lama 'tend' lam-ina 'tend for'
 b. sompoloka 'slip out' sompolok-ele 'slip out (PERF)'
 kunta 'shake' kunt-ila 'shake for'
 funga 'fold' fung-ulula 'unfold'

The root-suffix combinations in (8a) illustrate the harmony pattern, while those in (8b) show that the nasal component of a prenasalized consonant is not a trigger. The requirement that the trigger and target must be in adjacent syllables is confirmed by the forms in (9).

- (9) a. masa 'plaster' mas-ile 'plaster (PERF)
 b. masa 'plaster' mas-uhula 'unplaster'
 c. masa 'plaster' mas-uhuka 'get unplastered'

From the information provided by Döke and Odden, it can be concluded that nasalization is always arrested if a syllable beginning with a stop or fricative intervenes between the trigger and the potential target.

Nasalization in the Lamba and Kikongo patterns conforms to the following generalization:

(10) *Kikongo Nasalization*

Within a stem, a sonorant consonant to the right of a nasal consonant is a nasal.²

We can infer from this generalization that oral sonorant consonants are never found to the right of nasal consonants in these languages. The direct evidence is consistent with this conclusion. Given the Kikongo inventory in (11), the overtly non-nasal sonorant consonant is limited to /l/, and it never occurs to the right of a nasal consonant within the same stem.

(11) *Kikongo consonants*

Stops:	p	t	k	b	d	g
Fricatives:	f	s	v	z	ɣ	
Nasals:	m	n				
Liquids:	l					
Semivowels:	w	y				

The generalization in (10) predicts the absence of the pattern schematized in (12a), but it does not predict the impossibility of sequences like (12b) and (12c), where N is any nasal consonant and V any vowel. Nevertheless, the latter sequences in which voiced oral stops or continuants follow a nasal consonant in the same stem do not occur.

- (12) a. *[NV ... l]
 b. *[NV ... {b, d, g}]
 c. *[NV ... {v, z, V}]

Ao (1991:195–96, fn. 3) draws attention to these gaps in Kikongo, and the dictionary listings of both Bentley and Laman confirm the accuracy of the observation.

The distributional gaps represented by (12b–c) would be accounted for if the target of nasalization can be defined as a class that includes all phonetically voiced

²It would also be phonetically accurate if the term "sonorant consonant" were replaced by "voiced consonant".

segments. However, a class of voiced segments that includes both sonorants and obstruents is difficult to capture if the only available feature is [voice], because there is strong cross-linguistic evidence that this feature is redundant for sonorants. Given an inventory like that in (11), this redundancy should apply in Kikongo. Redundant features are not expected to have a classificatory function in the lexical component of the phonology. Therefore, one would not expect a process which qualifies as lexical in the sense of Kiparsky (1985) to apply to sonorants and voiced obstruents. From the perspective of Kiparsky's model of Lexical Phonology, consonant nasalization in both Lamba and Kikongo is a lexical process, because its application is restricted to root-suffix combinations only. On the basis of the observation that the triggering nasal consonant cannot be in a prefix, Hyman (1994) reaches a similar conclusion about the lexical status of the process.

The difficulty in capturing a voiced class of sonorants and obstruents is not insurmountable. Itô, Mester and Padgett (1995), exploiting the tenets of Optimality Theory, argue that certain requirements of a particular grammar may force sonorants to be phonologically specified for [voice]. However, there is another way to capture the class of phonetically voiced consonants. Rice (1993) points out that segments which resemble voiced obstruents are sometimes best analyzed as underlying sonorants. The traditional feature [voice] in such cases would be considered to be redundant for all voiced consonants and phonetic voicing would be epiphenomenal. Expressed in Rice's terms, the voiced oral stops and continuants in Lamba and Kikongo are "sonorant-obstruents". Given such a description, the generalization in (10) can be invoked as the explanation for the gaps illustrated in (12). Any voiced consonant to the right of a nasal would be subject to nasalization. Superficially, nasal harmony appears to target /l/ but only because it happens to be the only sonorant consonant that appears in suffixes.

The only other sonorants in the Kikongo inventory (11) are the semivowels. The occurrence of these segments seems to be at odds with the generalization in (10). In Kikongo, there are very few examples of semivowels in a context where they might be expected to be nasalized, but when they are found they are never nasalized.³ Consider the following verb stems, based on the root *nu* 'to drink':

- (13) a. nua 'to drink'
 nu-wa 'to be drunk'
 nu-wuka 'to be drunk (MID)'
 b. nu-ila [nwina] 'to drink with'
 c. nu-wunu 'to have been drunk'

The forms in (13a) show that semivowels are not subject to nasalization, while those in (13b–c) suggest that semivowels can be transparent.

The problem posed by semivowels would be solved if these segments were not members of the class of sonorant consonants. In many languages, semivowels alternate with high vowels (Kenstowicz 1994:23) and can, therefore, be described

³This statement is probably true of semivowels in Lamba also.

directly to some requirement that constituents α and β in a sequence agree for some feature F, surface representations like those in (16) would not qualify as harmonic. The final nasal does not agree in nasality with any preceding segment in either (16a) or (16b).

Instead of the alignment-theoretic constraints, I postulate that harmony is regulated by a set of constraints which command featural agreement (see also Piggott 1996). This family of constraints is referred to as Constituent Concord (CONCORD). For nasal harmony, the following are the relevant members of this family:

(17) *Constituent Concord* (CONCORD)

a. CONCORD-R

If constituent α is specified for Nasal in an input, then constituent β to the right of the correspondent of α in an output is also specified for Nasal, if α and β are in the same domain.

b. CONCORD-L

If constituent α is specified for Nasal in an input, then constituent β to the left of the correspondent of α in an output is also specified for Nasal, if α and β are in the same domain.

In the framework adopted in this article, the satisfaction of these agreement constraints is subject to universal wellformedness conditions. This means that harmony is always blocked, if the enforcement of agreement would yield an output which is universally prohibited.

As parametric options, the constraints in (17) yield four possibilities. The presence of both CONCORD-R and CONCORD-L results in a bi-directional harmony. If feature agreement is enforced in only one direction, harmony is either progressive (CONCORD-R) or regressive (CONCORD-L). The fourth possibility is the absence of harmony. This effect is achieved, if neither CONCORD-R nor CONCORD-L is enforced. In essence, the absence of nasal harmony can be treated as an unmarked property, the consequence of a failure to exercise any of the language-particular options. Unless a grammar specifically requires that Nasal be the feature that marks constituent agreement, the unmarked situation emerges (cf. McCarthy and Prince 1994).

It is generally recognized that harmonic patterns occur within words and not between words. The conception of harmony as constituent agreement therefore leads to the expectation that it may apply to any of the constituents that make up words, that is, segments, syllables or feet. Consequently, we expect three types of harmony:

(18) *A Typology of Harmony*

- Segment harmony (= segment-to-segment relation)
- Syllable harmony (= syllable-to-syllable relation)
- Foot harmony (= foot-to-foot relation)

To fulfill these expectations, phonological theory would have to allow features to be properties of constituents above the level of the segment. Evidence for this option is not difficult to find. It is most clearly expressed by certain patterns in the occurrence of the feature [nasal]. In a number of languages, the sonorant segments in a syllable are either all oral or all nasal. The Brazilian language, Kaingang, has such syllable types (Wiesemann 1972; Piggott 1995; Piggott and van der Hulst 1996). Monosyllabic words like those in (19a) are possible, while those in (19b) are impossible.

(19) *Syllable Nasalization* (Kaingang)

- | | | | | |
|----|------|-----------|----|------------|
| a. | rā | 'sun' | b. | *rā, *ra |
| | yā | 'tooth' | | *yā, *ya |
| | wān | 'taquara' | | *wān, *wan |
| | nā | 'lie' | | *nā, *na |
| | yāra | 'spit' | | *yāra |
| | kuṛā | 'day' | | *kūṛā |

Syllable patterns similar to those illustrated above are reported for Yoruba (Pulleyblank 1988), Isekiri (Omamor 1979), Jukun (Welmers 1973), Gbe (Capo 1981), and Chaoyang (Yip 1996).

Obviously, the possibility of a feature being associated with a suprasegmental category like the syllable is the result of a language-particular choice. Developing ideas from Itô (1986) and Goldsmith (1990), I express this as a licensing option; languages may designate the segment, the syllable or the foot as the licensor of a particular feature.⁵ I label the relevant constraint the "Designated Feature Licensor (X)", where (X) is some feature. Schematically, the options for the licensing of the feature [nasal] are represented as follows:

(20) *Designated Feature Licensor* (Nasal) / {Segment, Syllable, Foot} or
DFL(Nas) / {Seg, σ , Ft}

The licensor of the feature Nasal is either a segment, or a syllable or a foot.

The link between the licensing options in (20) and the typology of harmony in (18) should now be apparent. The level at which harmony holds depends on the category which is designated to be the licensor of the harmonic feature. For example, syllable harmony is possible only when the syllable is the licensor of the feature which expresses the harmony.

In a language like Malay, [nasal] is segmentally licensed and harmony takes the form of configurations like the following (where N = [nasal]).

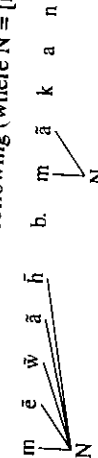
- (21) a. 

⁵The licensor of features may include the prosodic word, but this possibility is not clearly supported in the literature.

The harmonizing units are adjacent at the segmental level. Voiceless obstruent stops, which cannot be nasalized in any harmony pattern, must be opaque in a language like Malay. Segment-to-segment harmony can also be expressed by pharyngealization. An example of the latter is described by Kenstowicz (1994:42) and Davis (1995).

When [nasal] is licensed by a syllable, harmony takes the form of a relation between syllables. In such a pattern, non-nasalizable segments can be skipped. This type of segment skipping occurs in Barasano nasal harmony. Obstruents are transparent to the process:

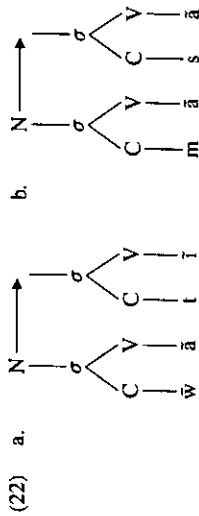

Segment skipping is also characteristic of vowel harmonies, where consonants are often ignored.

When a feature is prosodically licensed (i.e., licensed by a suprasegmental category), it is logical to expect that it would have scope over all the segments within its licensing category. Consequently, it should be realized on the segments that the category contains. However, the evidence from languages like Kaingang and Barasano where [nasal] is a syllabic feature reveals that a prosodically licensed feature is sometimes restricted to just a subset of the segments in a syllable. For example, in (19a) and (22), all sonorants in a syllable are nasalized, but this contrasts sharply with the behaviour of obstruents. In none of the languages where [nasal] is a property of syllables are obstruents ever subject to phonological nasalization. Hence, a nasal syllable in a language like Kaingang may contain an oral obstruent:

- (23) a. *kutã* 'fall' d. *kãta* 'guts'
 b. *hapã* 'good' e. *tõ* 'not'
 c. *kišã* 'moon' f. *šĩ* 'small'

The evidence from the distribution of nasality therefore indicates that a prosodically licensed feature must be allowed to have wide scope over all segments in a category, but it may also have narrow scope over just one segment. The two possibilities are captured by the principle of Initialization (cf. Piggott 1996; Piggott and van der Hulst 1996).

(24) *Initialization (INIT)*

- a. The feature F must be realized by as many segments as possible within the licensing category for F.
 b. At least one segment within the licensing category for F must bear F.

The first clause (24a) expresses a potential; it does not force a prosodically licensed feature to be borne by all the segments in the licensing category. However, we expect this potential to be actualized, unless some principled restriction dictates otherwise. The second clause of Initialization (24b) is not subject to any qualification; it is an absolute restriction which must always be met. It plays a crucial role in explaining how harmony is instantiated. When there is a harmonic relation between suprasegmental units, some segment in the harmonic relation must bear the harmonic feature.

It is the satisfaction of (24a) that forces the nasalization of all tautosyllabic sonorants in languages like Kaingang and Barasano, but the obligatory exemption of obstruents must still be explained. Although nasalized fricatives are phonetically possible (see Ladefoged and Maddieson 1996:132), these segments are never the result of nasalization in languages with nasal syllables. A window on the exemption of all obstruents from nasalization is provided by the theory of segment structure proposed by Piggott (1992) and Rice (1992, 1993). This theory organizes [nasal] under the SV (Sonorant Voice) node when it is a property of sonorants but places it under a different node when it is a property of an obstruent. The proposed difference is illustrated below:⁶

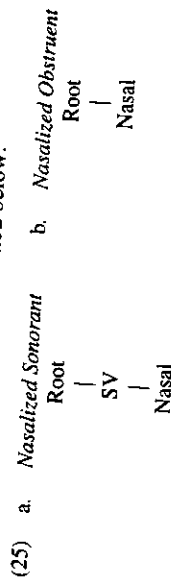

The difference between (25a) and (25b) can be described as a difference in the dependency of the feature [nasal], since it reports to distinct nodes. Given this variable dependency hypothesis, the incorporation of the following principle into the theory of phonology accounts for the absence of nasalized fricatives in Barasano and Kaingang:

(26) *Consistency Of Dependency Relation (CDR)*

A prosodically-licensed feature F must manifest the same dependency relation within every instance of a licensing category for F.

The features that are prosodically licensed usually originate from underlying nasal vowels. Vowels are therefore expected to be bearers of such features in surface representations, and this is often the case. However, when the feature is [nasal], another potential underlying source is a sonorant consonant. Whether the source of underlying nasality is a consonant or a vowel, when it is a prosodically-licensed feature, CDR limits its surface occurrence to sonorant segments. Hence,

⁶Piggott (1992) expresses the variable dependency in a different way. An equivalent distinction is made by Humbert (1995) in a model of segment structure based on the principles of Dependency Phonology (Anderson and Ewen 1987).

it guarantees that tautosyllabic sonorants are nasalized in Kaingang and Barasano, but obstruents are ignored phonologically.

I have now outlined the essential features of the theory of harmony which will be applied to the analysis of consonant nasalization in Lamba and Kikongo. The central idea is the conception of harmony as a relation which may hold between units at either the segmental or suprasegmental levels of representation. Once a language has determined the licenser of a given feature, the manifestation of harmonic patterns is regulated by the Locality Condition and the following principles:

(27) *Principles*

- a. Initialization (INIT)
- b. Consistency of Dependency Relation (CDR)

INIT makes the harmonic feature phonetically visible by requiring that it be realized by at least one segment within every unit in the relation, while CDR imposes restrictions on the segmental bearers of a harmonic feature.

The actual occurrence of harmony and the form it takes in particular instances are determined by the activation of constraints from the following set:

(28) *Parameters*

- a. Constituent Concord (CONCORD)
- b. Designated Feature Licensers (DFL)

The DFLs determine the level at which the harmonic feature is licensed, while the selection of a CONCORD constraint forces the feature to be distributed over adjacent members of the licensing category.

4. TWO SUPRASEGMENTAL HARMONIES

All descriptions of consonant nasalization in the Lamba and Kikongo patterns report that vowels between the trigger and target are skipped. The transparency of vowels is the signal that the harmonies are suprasegmental. If these patterns involved relations between segments, we might expect vowels to be nasalized as they are in languages like Malay, Sundanese, Aguaruna, Warao, and many others. Observation of the clear cases of segment-to-segment harmony reveals that, when segments are exempted from nasalization, they block the process. A ban on vowel nasalization should therefore make long-distance consonant nasalization by a segment-to-segment process impossible. When nasal harmony is a suprasegmental relation, vowels may undergo nasalization but are not required to do so. In both syllable and foot harmonies, it is possible for adjacent constituents to agree for nasality without imposing nasalization on vowels. The principle of Initialization only requires one segment in a syllable or a foot to bear a harmonic feature.

Of course, since vowels would be in the scope of a suprasegmentally licensed feature, their failure to bear the harmonic feature still has to be explained. Both

Lamba and Kikongo have no underlying nasal vowels. This restriction on the contrastive role of the feature [nasal] must be represented in the two grammars, independently of the description of nasal harmony itself. However, the same restriction lies behind the failure of vowels in the domain of nasal harmony to undergo nasalization. Kiparsky (1985) points out that phonological processes are often subject to a constraint which limits their outputs to structures which are possible in underlying representation. This constraint, called "Structure Preservation", regulates the output of processes which apply in the lexical component of the phonology. It should therefore exempt the vowels of Lamba and Kikongo from nasalization, because this process is demonstrably lexical in both languages. It is not crucial to the analysis of consonant nasalization that the exact form of the Structure Preservation constraint be provided. The following is a reasonable candidate:

(29) *Structure Preservation*

At the lexical level, a nasal vowel may appear in an output representation only if there is a corresponding nasal vowel in some underlying representation.

I will assume that the principle of Structure Preservation is universal. In the next two sections, I discuss the different impact of this principle on consonant nasalization in Lamba and Kikongo.

4.1. Syllable Harmony and Syllable Opacity

In the overview of the Lamba pattern in section 2, it was noted that the trigger and target are in adjacent syllables (e.g., *um-ine* 'dry' (PERF)/**um-ile*). If neither of the segments in a syllable can be nasalized, consonant nasalization is blocked (e.g., *mas-ile* 'plaster' (PERF)/**mas-ine*). This requirement of syllable adjacency is also noted by Odden (1994). Clearly, oral syllables block the harmony. The blocking of harmony by oral syllables is predicted by an analysis of consonant nasalization as an instance of syllable harmony. We would expect the harmonic relation to be instantiated between adjacent syllables and to be blocked if all the segments in a syllable are exempted from nasalization.

In terms of the theory of harmony proposed in section 2, the Lamba pattern is commanded by CONCORD-R (17a), repeated below as (30a), and the requirement that the Designated Feature Licenser for [nasal] be the syllable (30b).

(30) a. CONCORD-R

If the constituent α is specified for Nasal in an input, then the constituent β to the right of the correspondent of α in an output is also specified for Nasal, if α and β are in the same domain.

b. DFL(Nas)/{ σ }

The feature [nasal] must be licensed by a syllable.

These constraints are satisfied by a configuration like that in (31b), the output corresponding to the underlying root-suffix combination *min-uliuta* 'unswallow'.

(31) a. Underlying: min-utulua

b. Surface: minununa

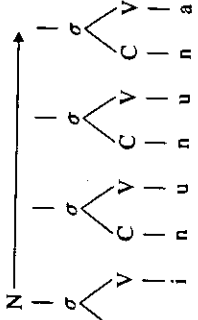

In the above representation, the principle of Initialization (24) is satisfied, because every harmonizing syllable contains at least one segment that bears the harmonic feature. The first clause of this principle (24a) gives [nasal] scope over vowels as well, but Structure Preservation prevents vowels from being nasalized. The apparent skipping of vowels does not constitute a violation of locality, because vowels are not among the units in the harmonic relation.

Let us now consider why harmony is blocked in Lamba. The underlying source of the harmonic feature is a nasal consonant. Hence, it can be assumed that the nasal-bearing segments in the output must include nasals. This assumption entails that [nasal] must consistently be an SV-dependent within the domain of harmony in accordance with the demands of CDR (26). Consequently, as I have argued earlier, only sonorant consonants can be nasal-bearers in Lamba. Underlying *mas-ile* 'plaster (PERF)' must have (32a) rather than (32b) or (32c) as the surface equivalent.

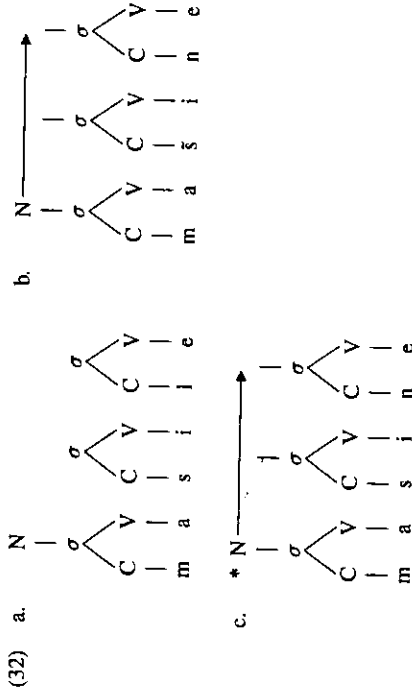

The first of the losers (32b) satisfies the Locality Condition and Initialization but violates CDR because fricatives and sonorants bear the feature [nasal]. The second loser (32c) satisfies the Locality Condition and CDR but the fact that the second syllable is oral induces a violation of Initialization. The remaining option (32a) where harmony is blocked must be the appropriate surface representation.

The combination of Structure Preservation (29) and CDR ensures that the second syllable of the word cannot bear nasality.

4.2. Foot Harmony and Syllable Transparency

Unlike Lamba, syllables are skipped in the Kikongo pattern (e.g., *kukin-is-ina* 'to cause to dance for' /**kukin-is-ita*). The logical interpretation of the facts is that syllables are not the harmonizing constituents. A harmonic relation at a prosodic level above the syllable would allow syllables to be skipped without incurring a violation of the universal Locality Condition (1). The prosodic unit that is immediately superordinate to the syllable is the foot. In its optimal size, the foot takes the form of a maximally binary unit which may contain up to two syllables (Hayes 1995). The evidence that the foot, like the syllable, can be a feature-licenser is quite robust, although it is often overlooked. I will first review the nature of this evidence and then show how syllable transparency in Kikongo nasal harmony is explained.

In certain well documented cases, the agreement pattern that is characteristic of vowel harmony is restricted to vowels in two adjacent syllables. For example, the *umlaut* phenomenon which occurs in German and in the history of other Germanic languages applies in a two-syllable window. Anderson (1980) recognizes this restricted pattern of vowel fronting in the Turkic language, Modern Uighur, and the Austronesian language, Chamorro. Another example of *umlaut*, the Korean case, has been discussed fairly recently by Charette (1989), Hume (1990) and Kenstowicz (1994).

Consider the Chamorro pattern as described by Topping (1973). In this language, back vowels /u, o, a/ change to their front counterparts /i, e, æ/ when certain particles/prefixes containing the front vowels are added to stems:

(33) Chamorro Vowel Fronting

a.	gúmaʔ (i-gʷ)maʔ	'house' 'the house'	c.	fóggon (ni-fég)gon	'stove' 'the stove'
b.	tókchaʔ (ni-ték)chaʔ	'your house' 'spear'	d.	lágu (sæn-lé)gu	'north' 'towards north'
	(ni-tek)cháʔ-mu	'the spear' 'your spear'			

In the above examples the domain of vowel fronting is parenthesized to show that the process is restricted to two syllables. It is also obvious that this domain is not determined by any other prosodic phenomenon such as stress assignment. Topping (1973:42) locates the primary stress in this language on the penultimate syllable:

(34) Chamorro Stress Placement

a.	hássso	'think'
b.	hináássso	'thought'
c.	hináássso mu	'your thought'

A representation like (38c) would also be ruled out by the Kikongo instantiation of Head Dominance, if the nasal consonant is an underlying segment:

(39) *Head Dominance (Kikongo)*

A segment bearing the feature [nasal] in an underlying/input representation is associated with the head syllable of a foot in the surface/output representation.

There is an important difference between H-DOM (36/39) and H-IDENT (37). H-DOM imposes a restriction on the appearance of underlying segments in feet, while it is irrelevant to H-IDENT whether the nasal consonant in the head position matches an underlying nasal.

Consider now how the surface form *kinununa*, corresponding to the underlying root-suffix combination *kin-ulula* 'to re-plant', must be parsed into feet. The results are shown in (40b) below.

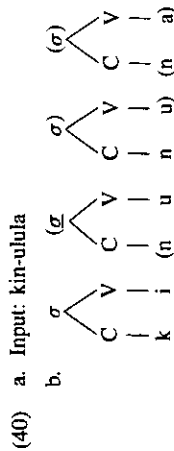

The only nasal consonant in the underlying representation is in the onset of the second syllable. This syllable must, therefore, be the head of an H-foot. Foot parsing then assigns the second and third syllables to a maximally binary foot, and the last syllable is organized as a degenerate foot under the assumption that as many syllables as possible are assigned to feet. In other words, foot parsing is persistent. The first syllable, which contains no nasal segment, is unfooted, since it cannot be incorporated into the same trochaic foot as the second syllable and it cannot constitute a degenerate foot. Notice that the last syllable in (40b) can constitute a foot, because it contains the head-identifying feature [nasal]. This occurrence of the feature is derivationally the result of the harmony process, but the important factor is that the foot is wellformed at the surface level.

The hypothesis that Kikongo harmony is a relation between feet entails that the Designated Feature Licensor for [nasal] is the foot. The two relevant parameters are presented below:

(41) *Conditions on Kikongo Harmony*

- a. $DFL(Nasal)/Ft$
The feature Nasal is licensed by a foot.
- b. CONCORD-R

If the constituent α is specified for Nasal in an input, then the constituent β to the right of the correspondent of α in an output is also specified for Nasal, if α and β are in the same domain.

The satisfaction of these requirements is achieved by the full structure of (40b), shown below as (42b).

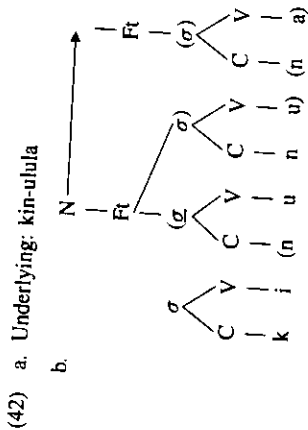

The configuration of elements in (42b) accounts for the nasalization of all sonorant consonants to the right of the underlying nasal. Since [nasal] has scope over both feet, the principle of Initialization (24) requires every sonorant in a foot to be a nasal-bearer except those that are exempted by Structure Preservation.

Let us turn next to the explanation for the transparency of obstruent-initial syllables in Kikongo. We already know that none of the segments in such syllable to remain unparsed or be assigned to the dependent position in a foot. These options are illustrated in the following surface representation of underlying *kudumuk-is-ila* 'to cause to jump for':

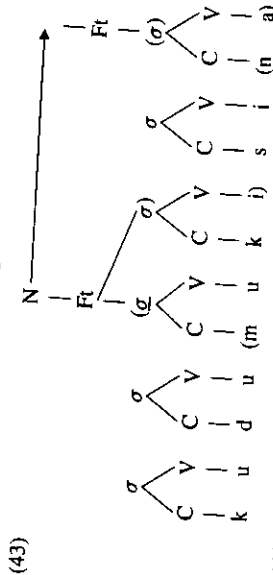

In (43) neither the first two syllables nor the penult can be footed. The unfooted penult is therefore invisible to progressive nasalization. The antepenult also fails to undergo nasalization, although it is part of a foot, but Initialization and the Locality Condition are still satisfied. Consequently, syllable skipping results from either the non-parsing of a unit or its prosodization as a dependent constituent.

4.3. *The Inertness of Prenasalized Consonants*

A complete analysis of harmony in Lamba and Kikongo must explain the behaviour of nasal contours. From a conventional perspective on harmony, the failure of these segments to initiate nasalization is somewhat problematic. There is strong evidence, presented in Herbert (1975, 1977, 1986), that prenasalized consonants in Bantu are formed by combining a nasal and an oral consonant and that the resulting structure contains a component which is specified for nasality. The strongest

evidence comes in two forms. Some languages undergo the process known as Meinhof's Law according to which a contour becomes a full nasal when the immediately following syllable contains either a nasal or another contour. Hence, nasal contours pattern with full nasals in triggering a nasalization process. The second form of the evidence is that in some languages (e.g., Ganda) nasal contours may trigger vowel nasalization in a context where even full nasal consonants do not. The restriction on vowel nasalization makes it clear that the process is phonological rather than phonetic.

If the prima facie evidence is accepted and prenasalized stops are represented as nasal-oral sequences, it is not obvious why nasality does not spread from a nasal consonant, considering that the process can skip oral segments. Compare a representation like (44a) that is supposed to be wellformed in a conventional analysis with the impossible (44b).

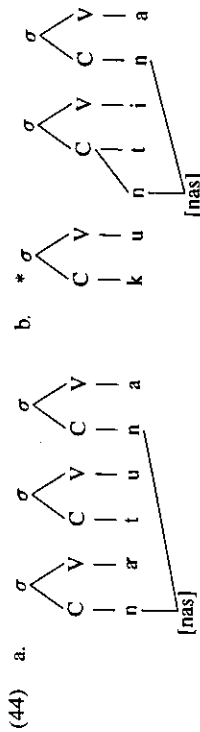

Why can /t/ be skipped as in (44a) but not as in (44b)? An even greater problem for the conventional approach to harmony is presented by the transparency of contours in Kikongo. All current theories of non-linear phonology consider a representation like the following to be ill-formed because of the crossing association lines:

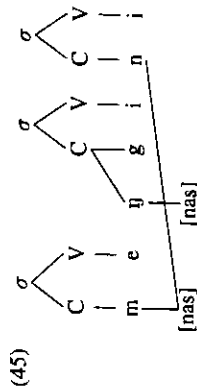

Nevertheless, we know that underlying *tu-megg-ili* 'we hated' must yield the output *meggini*.

The problems with which nasal contours confront the conventional analysis of harmony can easily be circumvented in the approach taken in this article. Consider, first, the observation that contours do not trigger nasalization in Lamba and Kikongo. Since harmony in these languages is a suprasegmental process, the behaviour of nasal contours is interpreted as evidence that these segments cannot initiate a process that applies at suprasegmental levels. This would follow from a requirement that [nasal] in contours be licensed at the segmental level. Because nasal contours in Lamba and Kikongo are formed from nasal-consonant (NC) sequences, I infer that the licensing restriction applies to all such sequences:

(46) *Licensing in NC-Sequences (LIC-in-NC)*

The licenser of Nasal is a segment if the feature is part of an NC sequence.⁸

This constraint seems to apply to all NC sequences in all languages. Hence, I will assume that it is a principle rather than a parameter of variation.

LIC-in-NC is obviously a licensing constraint of the same functional type as (20). While these constraints provide for variation in the licenser of [nasal], the most restrictive theory of feature licensing should limit the variation by permitting the licenser of a feature to be unambiguously determined in every instance. This effect is assured when the options are limited to those in (20). The parametric options built into this formulation indicate that languages must select between the segment, the syllable and the foot as the licenser of a feature. However, this restriction does not follow automatically when a universal constraint like LIC-in-NC (46) is added to the picture. An independent principle must be invoked to maintain a unique licenser for a given feature. This principle is referred to here and in Piggott (1996) as the Consistency of Licensing (CL):

(47) *Consistency of Licensing (CL)*

Within a phonological category which is the potential licenser of a feature F, the Designated Licenser of F cannot vary.

The Consistency of Licensing entails that the feature [nasal] in the Kikongo stem *kambila* 'to intercept' must be licensed either by a segment in accordance with Phonological theory as determined by (20) but not by both, takes precedence.

In the principles and parameters framework assumed in this article, the choice between (20) and (46) is regulated by the Elsewhere Condition (Kiparsky 1973). According to this condition, when one constraint always applies to a subset of the set of structures to which another constraint would otherwise apply, the satisfaction of the more specific constraint takes precedence over the more general one.⁹ Clearly, both DFL(Nasal){σ} and DFL(Nasal){Ft} are more general licensing constraints than LIC-in-NC, because NC sequences are always sub-domains within the syllable and the foot. This claim is illustrated in (48) below, where the two circles show two potential licensing domains for the feature [nasal].

⁸NC sequences are either contours or coda-onset clusters. The coda position and the first position in a contour are probably structurally related. The nasal consonant in both positions are either adjuncts or complements to dominant segments.

⁹Similar use of the Elsewhere Condition is made by Scobbie (1991, 1993) in the framework of Declarative Phonology.

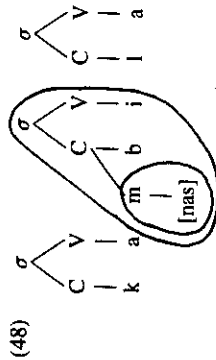

This configuration shows graphically that the smaller licensing domain provided by a unit that is part of a nasal contour will always be contained within a suprasegmental category. The Elsewhere Condition therefore entails that LIC-in-NC will always take precedence over DFL(Nasal){σ} (Lamba) and DFL(Nasal){Ft} (Kikongo). Since [nasal] in contours must be segmentally licensed, these segments could not initiate nasal harmony in either Lamba or Kikongo. The representations in (49) below are ill-formed.

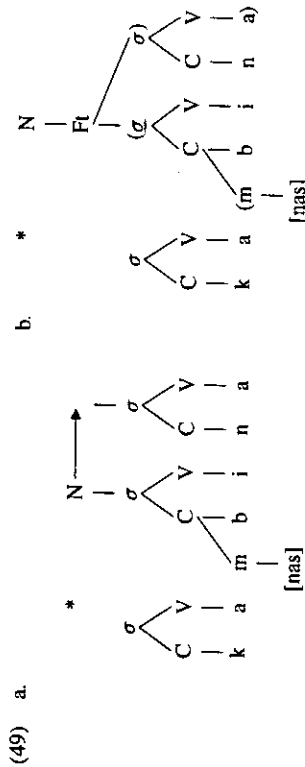

Let us next consider the question of why contours are transparent to nasal harmony in Kikongo. Recall that underlying *meŋg-ii* corresponds to surface *meŋgini* and not **meŋgii*. In Kikongo harmony the transparent unit is not the nasal contour itself but the syllable in which it occurs. Transparency is a signal that the invisible syllable is either in the dependent position in a foot (50a) or is unfooted (50b).

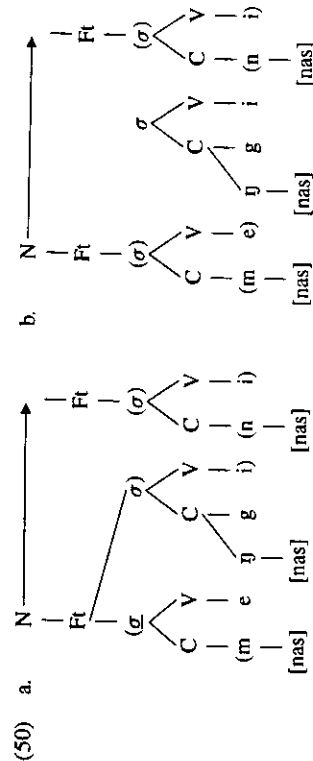

These representations have the same phonetic interpretation. However, (50a) can be ruled out, because it is incompatible with the Consistency of Licensing (47). Since LIC-in-NC must be satisfied, this representation indicates that the feature [nasal] is licensed suprasegmentally and segmentally, contrary to CL. The ill-formedness of (50a) means that the transparency of nasal contours to Kikongo harmony has to be the result of the syllables containing such segments being consistently unfooted.

One angle remains to be covered to complete this explanation of the behaviour of nasal contours in Lamba and Kikongo nasalization patterns. I must explain why syllables containing contours are not opaque to harmony in Kikongo. If syllables are freely parsed into feet, the output in (51) below would appear to be compatible with the theory of harmony developed so far.

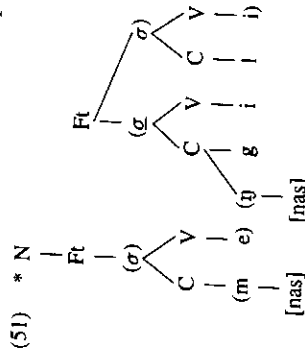

The requirement that [nasal] in a contour be segmentally licensed would combine with the principle of the Consistency of Licensing to prevent the spreading of nasality from the first foot to the second foot. This would force the final syllable of (51) to remain completely oral.

The opacity illustrated in (51) arises only if the second foot in this representation is wellformed, and it appears to be, because it contains a nasal segment in the head of the foot as required by Head Identification (37). This possibility reveals a serious flaw in the theory of harmony elaborated so far. It allows a feature to identify the head of a foot, even if that feature is restricted by licensing to segmental relations. Syllables, not segments, are heads of feet, but the theory seems to be claiming that the content of segments can determine what constitutes a head. The source of this anomaly is clearly the formulation of Head Identification (37). I therefore propose to modify this principle to eliminate the paradox which it engenders.

(52) *Head Identification (H-IDENT) (revised)*

The head syllable of the H-Foot must be associated with the H-Feature F.

This relatively minor change to the original statement in (37) has far-reaching consequences. It is no longer sufficient for a harmonic feature to appear somewhere in the head syllable of a foot. It is now necessary that the feature be a phonological

attribute of the syllable itself. In a wellformed representation like (50b), the feature [nasal] has scope over the heads of both H-Feet, because it is a property of the foot itself; H-IDENT is satisfied. This principle is not satisfied by the second foot of (51), because [nasal] can only be a segmental feature within the NC sequence; this representation is therefore ill-formed.

The inertness of nasal contours to nasal harmony in Lamba and Kikongo is now completely explained. The behaviour of these segments can be derived from the satisfaction of a single principle, LIC-in-NC (46). First, they cannot be responsible for a pattern of agreement between suprasegmental categories, because [nasal] is restricted to the status of a segmental feature in contours. Secondly, these segments are transparent to foot-to-foot harmony, because they are constituents of syllables which cannot be incorporated into feet. Finally, the fact that syllables containing contours cannot be footed ensures that these units cannot block harmony.

Let me now summarize the essential elements of the analysis of consonant nasalization in Lamba and Kikongo. I have argued that vowels and semivowels escape nasalization in both languages because of a Structure Preservation principle which requires non-consonantal segments to remain oral in the lexical component of the phonology. These oral segments can be skipped by harmony processes which apply to syllables and/or feet. In Lamba, where syllables harmonize, any syllable that cannot bear the harmonic feature must be opaque to harmony; the Locality Condition forces such an outcome. Non-harmonizing syllable can be skipped in the Kikongo pattern, because harmony is a foot-to-foot relation.

5. CONCLUDING REMARKS

This article offers a novel analysis of long-distance consonant nasalization. The core of the proposal, the hypothesis that features can be associated with suprasegmental categories, is not entirely new. It has some of its roots in the original conception of autosegmental theory as elaborated in the early 1970s (Leben 1973; Goldsmith 1976). In the earliest elaboration of this theory, features are autonomous units which may express relations between segments (i.e., Cs and Vs) as illustrated in (53a). This article extends this idea to allow features to express relations between syllables (53b) and feet (53c).

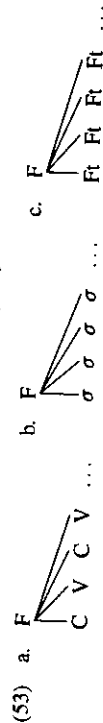

Apart from some works in the framework of Dependency Phonology (e.g., Humbert 1995), most analyses of harmony are expressed in terms of various elaborations of the original autosegmental model (53). Features are transferred from

one segment to another.¹⁰ The conventional approach to harmony therefore F an emphasis which can be characterized as segmentalism, in contrast with t prosodic approach advocated in this article.

I contend that the prosodic approach to consonant nasalization in Lamba and Kikongo is superior to conventional alternatives. Hyman (1994) observes that t transparency problem of Lamba and Kikongo harmonies remains largely unsolv in conventional autosegmental analyses that include various elaboration of featu geometry. One example of a conventional analysis is a description of Kikon harmony by Ao (1991). For Ao, nasalization is attributed to a process whi spreads the feature [nasal] from a root consonant to a target segment specified ; nonstrident and coronal. This account is actually descriptively inadequate, becau it does not capture the invisibility of non-strident, voiceless coronal stops. For example, Laman (1936) lists the following stem derivatives of the root *nat-* 'carry

- (54) a. *nat-ula* [natuna] 'carry back'
b. *nat-ila* [natina] 'carry with/for'

The segment /t/ should qualify as a target, but it is skipped. The skipping of suc a segment would be possible only if the Locality Condition is violated.

An additional shortcoming of Ao's account lies in the proposed solution t the problem of the inertness of the prenasalized consonants. It proposes to derivi both their transparency and their failure to trigger harmony from a missing [nasal] feature in their underlying representation. However, the hypothesis that prenasal in Kikongo and other Bantu languages are underspecified for the feature [nasal] cannot be sustained. In section 4.3, I draw attention to a number of properties these segments manifest which cannot be reconciled with their underspecification for the feature [nasal]. Since contours are partly nasal segments, they could not have the status of transparent segments in an analysis like Ao's.

Segmentalism also characterizes a more recent description of the Lamba and Kikongo patterns by Odden (1994). These patterns are introduced as support for the hypothesis that the Locality Condition does not demand that segments in a phonological relation be adjacent. Odden claims that adjacency is parameterized; the segments in a relation may be string-adjacent (root adjacency) or be in adjacent syllables (syllable adjacency) or be arbitrarily far apart. Chukchi, Lamba, and Kikongo are considered to have very similar rules of nasalization, differing significantly only in the setting of the adjacency parameter. The basic form of the rule proposed for Lamba and Kikongo is as follows:

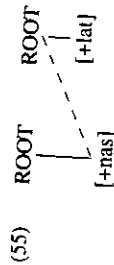

¹⁰Recent work in the framework of Government Phonology (cf. Backley and Takahashi 1996) does not fall into this category.

On this rule, Lamba imposes syllable adjacency, while Kikongo imposes no distance restriction. Since the targets of nasalization are [+lateral] segments, this analysis allows vowels to appear freely between trigger and target in both languages.

The Chukchi rule as stated by Odden is (56); it has counterparts in Korean and other languages.

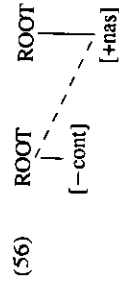

Some of the Chukchi data cited as evidence for the above rule are reproduced below:

(57)	repan	'flesh side of hide'	rəm-n-ət	'flesh sides of hides'
	pəjəl	'news'	ʔ(ə)-mpət-len	'having news'
	təm-ək	'to kill'	ʔ(ə)-nmə-len	'he killed'
	retan	'tooth'	rəm-n-ət	'teeth'
	təje-k	'to grow'	ʔ(ə)-nje-lin	'it grew'

The above alternations show that voiceless obstruent stops become nasals when they are string-adjacent to nasals. The root adjacency requirement of rule (56) ensures that vowels cannot appear between trigger and target.

Odden's analysis of long-distance consonant nasalization appears to make distinctions equivalent to those proposed in this article. The root adjacency requirement produces the same effect as segment harmony; the results of the imposition of syllable adjacency are equivalent to a description of harmony as a syllable-to-syllable relation; finally, the absence of any adjacency requirement yields a pattern like foot-to-foot harmony. However, the similarity between the two approaches is only superficial. The assumption that the long-distance nasalization patterns of Lamba and Kikongo are no more than the Chukchi pattern minus the root adjacency requirement is not supported by the evidence. Chukchi nasalization is clearly a process that can target voiceless obstruents. This contrasts sharply with the long-distance nasalization patterns where targets are invariably sonorants. A theory that promotes an analysis in which the Chukchi rule could simply be extended to long-distance patterns predicts a pattern in which vowels, semivowels and liquids are skipped and stops (voiced/voiceless) are targets. This pattern is unattested; there are no long-distance nasalization patterns that target only obstruent stops. Instead, consonant nasalization shares with other nasal harmony patterns in which segments are skipped the restriction that the targets are always sonorants. This restriction is difficult to express in a conventional description of the Lamba and Kikongo patterns as agreement for nasality between segments.

An analysis that attributes consonant nasalization to a rule like (55) is also unable to account for the inertness of nasal contours. We might expect these segments to initiate such a process, but we certainly would not expect them to

be transparent. This is a major weakness in all segmental accounts, but Odden's description of the Lamba and Kikongo patterns is vulnerable to additional criticism. Rule (55) accounts for the transparency of vowels and obstruents only if the description of the target as a [+lateral] segment is justified. In a consonant system like that in (11), it is not obvious that the liquid should be described as a [+lateral] segment rather than just a non-nasal sonorant. The determination of how targets must be described is important, because if they are described as [-nasal] segments the transparency of vowels and obstruents is more difficult to account for in the conventional conception of harmony as segment agreement.

I have shown in this brief critique that the theory of locality proposed by Odden (1994) does not generate an adequate description of the Lamba and Kikongo patterns. However, Odden's theory, which treats harmony as segmental assimilation, is also supposed to account for patterns of dissimilation. The alternative proposed in the present article rejects the characterization of harmony as no more than segmental assimilation, but it does not necessarily challenge the analysis of dissimilation. None of cases of dissimilation for which clear analyses are provided poses any problems for the conception of locality defended in this article. Both theories recognize segment-to-segment relations and cases of dissimilation seem to be fundamentally of this type. I assume that, in analyses of the latter phenomena, segment internal structure (i.e., feature geometry) would play a role in the determination of how adjacency is manifested in both theories. However, it is beyond the scope of this article to examine how adjacency must be defined in order to account for cases of dissimilation. The principles and parameters that regulate harmony do not have to be applicable to dissimilation.

A possible response to the problem posed by the transparency of vowels, obstruents and prenasals to nasalization in languages like Lamba and Kikongo is to abandon the conventional view that harmony is necessarily reducible to feature-sharing. This possibility has to be considered, because there is at least one alternative to feature-sharing in the literature. Archangeli and Pulleyblank (1994) have recently proposed that some apparent cases of harmony should be described as involving multiple occurrences of the same feature. According to this proposal, a Kikongo word like *kadamukisiŋa* would contain two occurrences of the feature [nasal]:

(58) $\begin{array}{c} \text{[nas]} \\ | \\ \text{k} \quad \text{u} \quad \text{d} \quad \text{u} \quad \text{m} \quad \text{u} \quad \text{k} \quad \text{i} \quad \text{s} \quad \text{i} \quad \text{n} \quad \text{a} \\ | \\ \text{[nas]} \end{array}$

In the above representation, the second instance of [nasal] is supposed to be an epenthetic feature, but the epenthesis is triggered by the presence of the first occurrence of [nasal].¹¹ Even if this general approach to harmony has merit in some cases, it does not yield an adequate account of the Lamba and Kikongo patterns. The inertness of prenasals is the Achilles heel of such an analysis of

¹¹ Pulleyblank (1994) develops this idea in the framework of Optimality Theory.

the consonant nasalization patterns. Because epenthesis is triggered when there is already an instance of [nasal] in the root, the failure of prenasals to trigger harmony would not have an obvious explanation.

The analysis of Kikongo harmony defended in this article is not immune to criticism, but I believe that any serious challenge can be met. A possible objection is that it introduces a new functional foot-type, the H-Foot, which is not motivated otherwise. Superficially, such criticism might appear to have some merit, but it is actually quite misleading. It is based on a common misconception that the postulation of foot level structure must be related to stress assignment. It is actually very well established that the foot can play a range of roles in phonology and morphology. For example, according to McCarthy and Prince (1990), the Arabic stress foot is a trochee, but the affix marking the broken plural is an iambic foot. Lombardi and McCarthy (1991) also recognize the independence of foot structure from stress. They relate a pattern of alternating vowel length in Choctaw to a condition on foot structure. Since we must accept that foot-level structure is required to explain a range of cross-linguistic phenomena, it would be an inexplicable coincidence if it were never involved in harmony. Objections to the H-Foot, therefore, cannot be taken seriously. Any objection to the postulation of such a unit would have to apply to the stress foot also.

The theory that explains consonant nasalization in this article seems to allow for the occurrence of other cases of long-distance consonant agreement. It is not possible at this stage of the re-thinking of the nature of harmony to take a definitive position on what is responsible for restrictions on consonant harmony. A useful line of research would be to investigate what types of features may be licensed by suprasegmental categories. One point of departure for this research could be the observation that every suprasegmental category is a constituent in which one of the sub-units qualifies as the head. The vowel occupies the head position of a syllable; one of the syllables in a foot qualifies as the head of the foot; and one of the feet in a prosodic word is the head-foot. Since linguistic constructions acquire properties from their heads, the following is probably an absolute restriction on the prosodic organization of features:

(59) *Head Feature Constraint (HFC)*

Any feature of a maximal projection (X_{max}) must be a possible feature of X, where X is the head of X_{max}.

We can deduce from this principle that any feature which may be licensed by a higher prosodic category must be compatible with vowels. Consequently, syllabic and foot harmonies may be restricted to those patterns in which harmonic features can be organized as vowel features.¹²

¹²The fact that secondary place features are vowel-like should allow them to be harmonic (Clements and Sezer 1982; van der Hulst and van der Weijer 1995), but it is not clear at present how to account for the limited role that secondary articulation seems to play in harmony processes.

When the familiar vowel harmony patterns are reanalyzed in terms of the theory of harmony presented in this article, processes like labial harmony in Turkish and ATR/RTR harmony in Yoruba would be described as syllable-to-syllable relations. These are patterns in which there are no transparent vowels. Transparency in vowel harmony is then a signal of a foot level relation. In Wolof (Ka 1988; Kenstowicz 1994), where non-high vowels to the left and right of high vowels systematically harmonize for ATR values, the agreement process applies to H-Feet:

(60) *Wolof ATR/RTR Harmony*

a.	tɛkki-leen	'untie'	b.	*tɛkki-leen
	watu-leen	'have haircut'		*watu-leen
c.	toxi-leen	'go and smoke'	d.	*toxi-leen
	lettu-leen	'braid hair'		*lettu-leen

Khalkha Mongolian labial harmony would also be analyzed as a case of foot harmony. In this pattern, the high, front unrounded vowel /i/ is always transparent:

(61) *Khalkha Mongolian Labial Harmony*

oril-ox	'to weep' (*oril-ax, *oril-ex)
oril-ogd-ox	'to be wept' (*oril-agd-ax, *oril-egd-ex)
xorin-ood	'by twenties' (*xorin-aad, *xorin-eed)
döci-ööd	'by forties' (*döci-aad, *döci-eed)

The transparent syllables of Wolof and Khalkha Mongolian are either assigned to the dependent position in H-Foot or remain unfooted.¹³

My analysis of consonant nasalization implies that harmony is part of the abstract design of grammar. The long distance relations that are manifested in Lamba and Kikongo cannot be reduced to the phonetic demands of these languages. While it is undoubtedly the case that some of the surface patterns of languages are phonetically determined, the development of a genuinely explanatory theory of phonology must recognize abstract relations of the type that figure crucially in the analysis presented in this article.

REFERENCES

- Anderson, John, and Colin Ewen. 1987. *Principles of Dependency Phonology*. Cambridge: Cambridge University Press.
- Anderson, Stephen. 1980. Problems and perspectives in the description of vowel harmony. In *Issues in vowel harmony*, ed. Robert Vago, 1-48. Amsterdam: John Benjamins.
- Ao, Benjamin. 1991. Kikongo nasal harmony and context-sensitive underspecification. *Linguistic Inquiry* 22:193-196.
- Archangeli, Diana, and Douglas Pulleyblank. 1987. Maximal and minimal rules: Effects of tier scansion. In *Proceedings of NELS 17*, ed. Joyce McDonough and Bernadette Plunkett, 16-35. GLSA: University of Massachusetts, Amherst.

¹³An analysis of labial harmony in Khalkha Mongolian is provided in Piggott (1996).

- Archangeli, Diana, and Douglas Pulleyblank. 1994. *Grounded phonology*. Cambridge, Mass.: MIT Press.
- Backley, Philip, and Yoromi Takahashi. 1966. Activate α : Harmony without spreading. *UCL Working Papers in Linguistics* 8:487-518.
- Bentley, William H. 1887. *Dictionary and grammar of the Kongo language*. London: Baptist Missionary Society.
- Capo, H.C. 1981. Nasality in Gbè: A synchronic interpretation. *Studies in African Linguistics* 12:1-43.
- Charette, Monik. 1989. The minimality condition in phonology. *Journal of Linguistics* 25:159-189.
- Chomsky, Noam. 1981. *Lectures on government and binding*. Dordrecht: Foris.
- Clements, George N., and Elizabeth Hume. 1995. The internal organization of speech sounds. In *Handbook of phonological theory*, ed. John Goldsmith, 244-306. Oxford: Blackwell.
- Clements, George N., and Engin Sezer. 1982. Vowel and consonant disharmony in Turkish. In *The structure of phonological representations*, vol. II, ed. Harry van der Hulst and Norval Smith, 213-255. Dordrecht: Foris.
- Cole, Jennifer, and Charles Kisseberth. 1994. An optimal domains theory of harmony. *Studies in Linguistic Sciences* 24(2):1-13.
- Davis, Stuart. 1995. Emphasis spread in Arabic and grounded phonology. *Linguistic Inquiry* 26:465-498.
- Doke, Clement M. 1938. *The text book of Lamba grammar*. Johannesburg: Witwatersrand University Press.
- Dresher, B. Elan, and Harry van der Hulst. 1995. Head-dependent asymmetries in phonology. In *Leiden in last: HIL papers in phonology* 1, ed. Harry van der Hulst and Jeroen van der Weijer, 401-431. The Hague: Holland Academic Graphics.
- Goad, Heather. 1993. On the configuration of height features. Doctoral dissertation, University of Southern California.
- Goldsmith, John. 1976. *Autosegmental phonology*. Doctoral dissertation, Massachusetts Institute of Technology.
- Goldsmith, John. 1990. *Autosegmental and metrical phonology*. Oxford: Blackwell.
- Hayes, Bruce. 1995. *Metrical stress theory*. Chicago: University of Chicago Press.
- Herbert, Robert K. 1975. Reanalyzing prenasalized consonants. *Studies in African Linguistics* 6(2):105-123.
- Herbert, Robert K. 1977. Phonetic analysis in phonological description: Prenasalized consonants and Meinhof's rule. *Lingua* 43:339-373.
- Herbert, Robert K. 1986. *Language universals, markedness theory, and natural phonetic processes*. Berlin: Mouton de Gruyter.
- Hulst, Harry van der, and Jeroen van der Weijer. 1995. Vowel harmony. In *Handbook of phonological theory*, ed. John Goldsmith, 495-534. Oxford: Blackwell.
- Humbert, Helga. 1995. Phonological segments: Their structure and behaviour. Doctoral dissertation, Holland Institute of Generative Linguistics.
- Hume, Elizabeth. 1990. Front vowels, palatal consonants and the rule of umlaut in Korean. In *Proceedings of NELS 20*, ed. Juli Carter, Rose-Marie Déchaine, Bill Philip and Tim Sherer, 230-243. GLSA: University of Massachusetts, Amherst.
- Hyman, Larry. 1994. Nasal consonant harmony at a distance: The case of Kiyaka. Ms., University of California, Berkeley.

- Itô, Junko. 1986. Syllable theory in prosodic phonology. Doctoral dissertation, University of Massachusetts, Amherst.
- Itô, Junko, Ralf-Armin Mester, and Jaye Padgett. 1995. Licensing and underspecification in Optimality Theory. *Linguistic Inquiry* 26:571-613.
- Ka, Omar. 1988. Wolof phonology and morphology: A nonlinear approach. Doctoral dissertation, University of Illinois, Urbana.
- Kenstowicz, Michael. 1994. *Phonology in generative grammar*. Oxford: Blackwell.
- Kiparsky, Paul. 1973. Elsewhere in phonology. In *A festschrift for Morris Halle*, ed. Stephen Anderson and Paul Kiparsky, 93-106. New York: Holt, Rhinehart and Winston.
- Kiparsky, Paul. 1985. Some consequences of lexical phonology. *Phonology Yearbook* 2:83-138.
- Ladefoged, Peter, and Ian Maddieson. 1996. *Sounds of the world's languages*. Oxford: Blackwell.
- Laman, Karl E. 1936. *Dictionnaire Kikongo-Français*. [Republished in 1964]. New Jersey: Gregg Press.
- Leben, William. 1973. Suprasegmental phonology. Doctoral dissertation, Massachusetts Institute of Technology.
- Lombardi Linda, and John McCarthy. 1991. Prosodic circumscription in Choctaw. *Phonology* 8:37-71.
- McCarthy, John, and Alan Prince. 1990. Foot and word in prosodic morphology: The Arabic broken plural. *Natural Language and Linguistic Theory* 8:209-283.
- McCarthy, John, and Alan Prince. 1993. Generalized alignment. *Yearbook of morphology* 79-153.
- McCarthy, John, and Alan Prince. 1994. The emergence of the unmarked. *Proceedings of NELS 24*, ed. Mercè González, 333-379. GLSA: University of Massachusetts, Amherst.
- Odden, David. 1994. Adjacency parameters in phonology. *Language* 70:289-330.
- Omamor, A.P. 1979. A phonological sketch of Isikiri. *Afrika und Übersee* 62:190-223.
- Piggott, G.L. 1992. Variability in feature dependency: The case of nasality. *Natural Language and Linguistic Theory* 10:33-77.
- Piggott, G.L. 1995. Feature dependency in Optimality Theory: Optimizing the phonology of sonorants. Ms., McGill University.
- Piggott, G.L. 1996. Reconfiguring harmony. *McGill Working Papers in Linguistics* 12:61-98.
- Piggott, G.L., and Harry van der Hulst. 1996. Local harmony of nasal harmony. Ms., McGill University and Leiden University.
- Prince, Alan, and Paul Smolensky. 1993. Optimality and the University of Colorado at Boulder.
- Pulleyblank, Douglas. 1988. Vocalic underspecificity. *Linguistics* 26:233-270.
- Pulleyblank, Douglas. 1994. Neutral vowels in C Yoruba and Wolof. Ms., University of British Columbia.
- Rice, Keren. 1992. On deriving sonority: A struct. *Phonology* 9:61-99.
- Rice, Keren. 1993. A reexamination of the feature obstruents'. *Language* 69:308-344.

- Scobbie, James. 1991. Attribute value phonology. Doctoral dissertation, University of Edinburgh.
- Scobbie, James. 1993. Constraint violation and conflict from the perspective of declarative phonology. In *Canadian Journal of Linguistics* 38: *Constraint-based theories in multilinear phonology*, ed. Carole Paradis and Darlene LaCharité, 155–167.
- Shaw, Patricia. 1991. Consonant harmony systems: The special status of coronal harmony. In *The special status of coronals: Internal and external evidence*, ed. Carole Paradis and Jean-François Prunet, 125–157. San Diego: Academic Press.
- Steriade, Donca. 1993. Closure, release and nasal contours. In *Nasals, nasalization, and the velum*, ed. Marie Huffman and Rena Krakow, 401–470. San Diego: Academic Press.
- Steriade, Donca. 1995. Underspecification and markedness. In *Handbook of phonological theory*, ed. John Goldsmith, 114–174. Oxford: Blackwell.
- Topping, Donald. 1973. *Chamorro reference grammar*. Honolulu: University of Hawaii Press.
- Welmers, William E. 1973. *African language structure*. Berkeley: University of California Press.
- Wiesemann, Ursula. 1972. *Die Phonologische und Grammatische Struktur der Kaingang Sprache*. The Hague: Mouton.
- Yip, Moira. 1996. Lexicon optimization in languages without alternations. Ms., University of California, Irvine.

Reviews Comptes rendus

Habaka J. Feghalli. *Arabic Adeni Textbook*. Arabic Dialect Series (Yemen). Edited by Alan S. Kaye. Wheaton, Maryland: Dunwoody Press. 1991. Pp. xx + 233 (hardcover).

Habaka J. Feghalli. *Arabic Adeni Reader*. Arabic Dialect Series (Yemen). Edited by Alan S. Kaye. Wheaton, Maryland: Dunwoody Press. 1991. Pp. viii + 265 (hardcover).

Reviewed by Wolf Leslau, *University of California/Los Angeles*

The *Textbook* consists of 30 lessons, nearly each of which has the following sections: dialogue, model sentences, (grammatical) notes, vocabulary, drills, and situations.

I know from experience how difficult it is to write a textbook, having myself compiled an "Amharic Textbook" (1968). In a way my task was easier than that of the author of the Adeni textbook because mine was explicitly intended for the beginner whereas the Adeni seems to be intended for the beginner (the author does not specify clearly) as well as for the one who has *some* (italics mine) acquaintance with Modern Standard Arabic (MSA). In my opinion this textbook does not satisfy the needs of the beginner. As for the learner who has some acquaintance with MSA, I wonder whether he will understand the value of the particle *b* in the sentence *mata bayibda' assaf haqqana?* 'when will our class start?' (p. 3, no. 29; see also no. 31). Likewise the expression *idnukum* in the sentence *raxxišani 'an idnukum* 'excuse me (to a group)' (p. 11) requires an explanation. I fail to understand the author's statement that the hamza "'is not a letter, but an auxiliary sign" (p. xvi). There is no doubt that in *sa'al, rā'* the symbol ' is a glottal stop. It is also doubtful that *ā* is like the *a* in "cab" (p. xvii).

As useful as the sentences in the sections such as "Dialogue" (pp. 5, 45), "Model Sentences" (pp. 6, 46, and passim) may be, the learner, even if he has *some* acquaintance with MSA, is at a loss how to analyze these sentences. Indeed, how can he analyze *a'iri* (and *habli*) in the sentence *mir faḍlak a'iri/habli iktāb haqqi* 'please give me my book' (p. 11) since these forms are not previously discussed? Possibly the author's intention was to ask the student to memorize these sentences without being able to analyze them, a procedure that does not seem to be sound from a pedagogical point of view.

In the section "Drill" (as on p. 8), the student is again asked to repeat the following: *faqadnālak 'we missed you'* (m.), *faqadnālih 'we missed her'*, and so on. Note, however, that the analysis of these forms is not easy for the beginner. Indeed, he has to be given to understand that the word consists of three elements: verb *faqad*, preposition *la* combined with the possessive suffixes.

The enumeration of the verbs and their conjugation without classifying them into the various verbal patterns (pp. 8, 20, 34) is confusing. Indeed, the listing of the imperfect forms *yifāid* alongside with *yušbih* and *yirāh* is not helpful.