

**Event Structure and the Encoding of Arguments:
The Syntax of the Mandarin and English Verb
Phrase**

by

Jimmy Lin

Submitted to the Department of Electrical Engineering and Computer
Science

in partial fulfillment of the requirements for the degree of

Doctor of Philosophy

at the

MASSACHUSETTS INSTITUTE OF TECHNOLOGY

August 2004

© Massachusetts Institute of Technology 2004. All rights reserved.

Author

Department of Electrical Engineering and Computer Science

August 3, 2004

Certified by

Boris Katz

Principal Research Scientist

Thesis Supervisor

Accepted by

Arthur C. Smith

Chairman, Department Committee on Graduate Students

Event Structure and the Encoding of Arguments: The Syntax of the Mandarin and English Verb Phrase

by
Jimmy Lin

Submitted to the Department of Electrical Engineering and Computer Science
on August 3, 2004, in partial fulfillment of the
requirements for the degree of
Doctor of Philosophy

Abstract

This work presents a theory of linguistic representation that attempts to capture the syntactic structure of verbs and their arguments. My framework is based on the assumption that the proper representation of argument structure is event structure. Furthermore, I develop the hypothesis that event structure *is* syntactic structure, and argue that verb meanings are compositionally derived in the syntax from verbalizing heads, functional elements that license eventive interpretations, and verbal roots, abstract concepts drawn from encyclopedic knowledge. The overall goal of the enterprise is to develop a theory that is able to transparently relate the structure and meaning of verbal arguments. By hypothesis, languages share the same inventory of primitive building blocks and are governed by the same set of constraints—all endowed by principles of Universal Grammar and subjected to parametric variations.

Support for my theory is drawn from both Mandarin Chinese and English. In particular, the organization of the Mandarin verbal system provides strong evidence for the claim that activity and state are the only two primitive verb types in Chinese—achievements and accomplishments are syntactically-derived complex categories. As a specific instance of complex event composition, I examine Mandarin resultative verb compounds and demonstrate that a broad range of variations can be perspicuously captured in my framework. I show that patterns of argument sharing in these verbal compounds can be analyzed as control, thus grounding argument structure in well-known syntactic constraints such as the Minimum Distance Principle. Finally, I argue that cross-linguistic differences in the realization of verbal arguments can be reduced to variations in the way functional elements interact with verbal roots.

Overall, my work not only contributes to our understanding of how events are syntactically represented, but also explicates interactions at the syntax-semantics interface, clarifying the relationship between surface form, syntactic structure, and logical form. A theory of argument structure grounded in independently-motivated syntactic constraints, on the one hand, and the semantic structure of events, on the other hand, is able to account for a wide range of empirical facts with few stipulations.

Thesis Supervisor: Boris Katz
Title: Principal Research Scientist

Acknowledgments

Although situated at the beginning of my thesis, this section was the last to be completed chronologically. As I jokingly complained to Boris, I was having writer’s block. . . not on any technical matters, but on properly acknowledging the many people that have accompanied me on my incredible journey through MIT over the past seven years—from undergrad, through m. eng, and finally ph.d. This marks the end of my formal education, and the beginning of my career in academia, something I look forward to with a combination of excitement and apprehension. But I’m getting ahead of myself. For the longest time, the appropriate words to express my heart-felt gratitude simply eluded me. The following is my rough essay.

I am not a linguist, but a computer scientist, by training. Yet, this thesis is a work in theoretical linguistics. This I owe to Alec Marantz, for not only teaching me about linguistics, but also how to *be* a linguist. When I first got in touch with him nearly a year ago, I knew that I was interested in pursuing a theoretical inquiry into argument structure and lexical semantics, but I was ill-equipped to tackle such an undertaking. I was very surprised by his enthusiasm and willingness to work with me, being a student from outside the linguistics department. I must have impressed him somehow, but whatever it was, it certainly wasn’t my knowledge of linguistics—I had no formal training beyond a couple undergraduate courses. I am grateful that Alec took me under his wing; what little I know now is a direct result of my weekly meetings with him, where he no doubt has often endured my embarrassing ignorance of this vastly complex field. Alec is a wonderful advisor, and his clarity of thought has been incredibly valuable in helping me untangle the complex and intricate web of verbal phenomena, and in helping me sort through many alternative analyses. When I was at a loss for words in praising Alec, I looked through theses of his recent students to see how they have thanked him. Liina phrased it the best: “Alec has the rare talent of being a mentor without ever telling you what to do”. The most remarkable fact about Alec’s style is that, despite his obvious theoretical influences in this work, the ultimate product is a theory that I nevertheless feel “is mine”.

My path to this present theory of verbal argument structure has been long and circuitous. Previously, I have worked on, and still continue to build, applications that provide humans efficient access to information using natural language. My career in computational linguistics and natural language processing I owe to Boris Katz, with whom I have been working since my arrival at MIT seven years ago. Back then, I was a young, brash freshman, seeking a passion toward which to devote my seemingly boundless energy. I’d like to think that I’ve come a long way since then, and I am eternally grateful that Boris has seen me through every step of the way, both the good, the bad, and the ugly (and yes, there were plenty of all three). I am forever indebted to him for providing me the opportunity to do great work, the environment to excel, the freedom to grow, and the support to achieve excellence. Boris taught me to appreciate language, with its incredible intricacies and subtleties—to take a step back and marvel at this amazing cognitive faculty we are all endowed with. Most important of all, Boris taught me that doing research isn’t like doing a problem set, the weekly cycle of do-it-then-forget-about-it homeworks ubiquitous in the undergraduate

curriculum. Any problem worth tackling cannot be solved in the course of a week, or even a month; research breakthroughs require inspiration, dedication, sacrifice, and most of all, perseverance. And yes, I will always remember his lectures on drinking too much.

I was pleasantly surprised that C.-T. James Huang agreed to be on my thesis committee. This being Jim’s sabbatical year, he wanted to disappear from all us pestering students. I’d like to say it was *yuan₂ fen₄*, but regardless, my few interactions with Jim have left me in awe. In an extremely short amount of time, he was able to penetrate my work and point out deep, unresolved issues with which I had been struggling. His insightful comments lead to a re-structuring of a critical analysis, post-defense. In the end, he left me with a much stronger piece of work than that which I initially had.

Michael Collins and Patrick Winston rounded out the rest of my committee. I must thank both of them for their interest in this work, even though it aligned marginally, at best, with their own research agendas. Mike was extremely helpful in pointing out aspects of the work that were not clear; some of these points were muddled prose (which I have since corrected), but others were unresolved research issues I was forced to confront head-on. My work is all the better for it. Patrick has been a great influence on my academic career; I fondly remember the many discussions we had about the wonders of human cognition and the contributions of vision and language to our ability to reason and learn. Above all, however, I shall remember him for his advice on how to present oneself, one’s research, and one’s accomplishments. Vision, step, news are three words that will forever be ingrained in me.

In the early stages of this work, Hooi Ling Soh helped me enormously with the vast literature on Mandarin Chinese. Like Alec, she endured my ignorance of the subject and patiently listened to my half-baked ideas without prejudice. I’d also like to thank Danny Fox, Irene Heim, Sabine Iatridou, and Shigeru Miyagawa for many helpful discussions and advice along the way. I especially appreciate Sabine for giving me a hard time and questioning my most basic assumptions. I owe Beth Levin for helpful comments on an earlier manuscript, and would like to thank Andrew Koontz-Garboden for discussions and mutual encouragement. I must also thank all the people who have provided me with judgments, both in English and in Mandarin. They have been enormously helpful in confirming my own intuitions and helping me navigate the murky waters of grammaticality.

Before I leave Cambridge, I must thank MIT for being at the center of all these amazing memories. But thanks alone just won’t do it. I love this place. This is such a strange thing to say, because what exactly is MIT? It certainly isn’t the administration, whose policies and decisions over the last several years I find at times idiotic. It certainly isn’t the physical buildings; not our charming but decrepit old home in NE43, nor our modern-yet-uninhabitable zoo in Stata. Maybe it’s the infinite corridor? No, MIT isn’t anything physical. To me, it is a state of mind. An MIT existence is one that truly mirrors the cliché, “work hard, play hard”. MIT is about living life to the fullest, at the extremes—with neither compromise nor moderation. MIT is about a masochistic attitude toward work, a (usually self-imposed) drive that takes one to the brink of total physical, mental, and emotional exhaustion. MIT

is about compensating for the aforementioned self-inflicted atrocities by engaging in equally extreme forms of play, usually involving activities that are best left unsaid in polite company. Virgil sums it the best: “Forsan et haec olim meminisse iuvabit”, which loosely translates to “someday, perhaps, the memory of even these things will be pleasant”. Even now, every one of these memories evokes nothing but fondness.

“Love and work are the cornerstones of our humanness” is a quote often attributed to Sigmund Freud. I couldn’t agree more. No journey through life is made alone, and I must acknowledge the people that have accompanied me intimately along the way. I have loved and lost many times. I have been hurt in the process, and done my share of hurting others. I have lost my way and rediscovered my path. Little justice can be done to the impact Cindy, Jennifer, Steen, Alice, and others have left on me. Each has taught me something about myself, about love, and about life in general: Cindy for being my first love (as they say, the one against which all subsequent relationships are measured). Jennifer for irrationality and darkness. Steen for intense passion. Alice for ultimately proving that love is not something you feel, but rather something you do (to take a quote from *American Wedding*). Over the last several years, many moments were sweet, others bittersweet, and some just plain bitter. Although they have all ended, I regret nothing, save the relentless passage of time.

I also couldn’t have gotten through the last seven years without the support of my friends; a special shout out to my boyz Ab, Nik, Rooz, and Fung. They were around for successes, failures, blossoming romances, failed relationships, and many of life’s memorable moments. There are so many other friends that I don’t have the space to thank individually, from undergrad, from the lab, colleagues, and former students. You know who you are. Thank you for everything, for putting up with my arrogance and my irreverence. Thank you for letting me be me. I realize that I’m still a work in progress, a little rough around the edges, but I hope that you are all proud to call me a friend.

Finally, I would like to recognize Kiri, my little Shiba Inu. She has been a most loyal companion and untiring confidante (not to mention an amazing chick magnet). Seeing her cute little face and soulful eyes never ceases to melt my heart. Seeing her wagging tail and playful dance never ceases to bring a smile to my face. Truly, a man’s best friend.

This thesis is dedicated to my parents, who have sacrificed much for my education, the hardest of which was probably not being able to see me for extended periods of time. I have lived in this country by myself since I was thirteen years old—although it has been rough at times, I can’t imagine the how hard it was to let me go, knowing that the path I’ve chosen is the best one. The culmination of my studies represents the realization of a dream, both theirs and mine. With utmost respect, gratitude, and love from the bottom of my heart, this is for you.

Contents

1	Introduction	11
1.1	From Semantic Roles to Event Structure	15
1.1.1	Semantic Roles	15
1.1.2	Event Types and Lexical Semantics	19
1.1.3	A Survey of Event Representations	24
1.1.4	From Linking Theory to Syntactic Representations	28
1.2	Framing a Theory of Argument Structure	31
1.2.1	Basic Event Structures	33
1.2.2	Causation and the Theory of Voice	40
1.2.3	Underlying Syntactic Processes	43
1.3	Key Claims	47
1.4	Roadmap	48
2	The Mandarin Verbal System	51
2.1	Salient Features of Mandarin Chinese	53
2.2	Previous Work	54
2.2.1	Deriving Accomplishments and Achievements	54
2.2.2	The Particle <i>le</i>	55
2.3	Activities and States	61
2.3.1	Activity/Achievement Verb Pairs	61
2.3.2	Incremental Theme Verbs	63
2.4	Inchoativity	74
2.5	Activities or States?	78
2.6	Accomplishments or Achievements?	80
2.7	Stative Verbs and the Perfective Aspect	83
2.8	Conclusion	87
3	Mandarin Resultative Verb Compounds	89
3.1	Basic RVC Classification	91
3.2	Spurious Verbal Compounds	96
3.3	Inventory of Issues	98
3.3.1	The Direct Object Restriction	98
3.3.2	Which verb is the direct object an argument of?	102
3.3.3	Causatives and External Arguments	105
3.4	The Basic Syntax of Verbal Compounds	107

3.5	The Syntax of Spurious Compounds	118
3.6	Control	121
3.7	Causation and the External Argument	129
3.8	Semantic Restrictions and the <i>de</i> Construction	141
3.9	The Syntactic Nature of Event Structure	143
	3.9.1 Deriving Inchoatives from Causatives	145
	3.9.2 Verbal Compounds in Mandarin	149
3.10	Comparison with Other Approaches	152
	3.10.1 The Small Clause Analysis	153
	3.10.2 Stacked VP Structures	157
3.11	Conclusion	163
4	Cross-linguistic Variations	165
4.1	Stative Roots	166
4.2	Different Languages, Different Choices	170
4.3	Resultative Participles in English	173
4.4	Conclusion	176
5	Concluding Remarks	177
A	Abbreviations	179

Chapter 1

Introduction

There is a general consensus among linguists today that argument structure is, to a large extent, predictable from event semantics. It is believed that the realization of verbal arguments is governed by event structure—representation of events and their participants. In this work, I present a theory of verbal argument structure that not only attempts to explain how arguments are syntactically and semantically licensed, but also the process by which verb meanings are compositionally constructed from conceptual primitives. The goal is to understand verbal argument structure in terms of syntactically-encoded primitives, on the one hand, and in terms of independently-motivated syntactic principles, on the other hand.

My theory, therefore, is a theory of linguistic representation; more specifically, it is one that grounds the meaning of verbs in the structure of the events they denote. As such, my account must minimally:

- (1) a. define the nature of the primitive building blocks that enter into linguistic computation,
- b. characterize the manner in which the basic units combine into complex representations, and
- c. identify the ways in which languages may differ with respect to their inventory of possible representations.

(Pylkkänen, 2002:9)

All three requirements will be addressed in this work. I posit an inventory of three conceptual primitives, or verbalizing heads—licensors of events representing activity, inchoativity, and stativity. These syntactically-encoded primitives combine with verbal roots drawn from the ontological categories of activity and state to form the basic building blocks of event structure. In the syntactic derivation process, verbalizing heads structurally license eventive interpretations, and verbal roots participate in the structure building process as event modifiers. These primitive building blocks combine according to well-known syntactic processes such as MERGE (Chomsky, 1995) and are subjected to well-studied constraints such as the Minimum Distance Principle (Rosenbaum, 1967). A key claim of my theory is that verb meaning, i.e., a

verb’s lexical semantic representation, is composed in the syntax from a fixed, universal inventory of functional elements and an open collection of concepts, drawn from encyclopedic knowledge. A verb does not directly encode a complete, well-formed lexical semantic structure; rather, my framework is non-lexicalist in that the “semantic load” is distributed more evenly among overt and covert morphemes, many not typically thought to bear semantic content—this is what Borer (2001) calls the “endo-skeletal approach” to argument structure. The overall aim of this enterprise is to explicate syntax–semantics interface and to develop a more transparent account of the relationship between surface form, syntactic structure, and logical form.

In support of my theory, I will draw upon evidence from both Mandarin Chinese and English. Mandarin is an appropriate target of study because the organization of its verbal system closely mirrors my system of functional heads and roots in a transparent manner. I claim that activity and state are the only two primitive verbal categories in Mandarin, and will demonstrate how the argument structure of more complex verbs are syntactically derived from these basic types. As a specific instance of complex event composition, this work will closely examine resultative verb compounds in Chinese, both at the typological and syntactic level. Another focus of my work is cross-linguistic variations in the encoding of argument structure. In particular, I will examine in detail the “inchoative core” of Mandarin and English sentences, and show that many key differences in syntactic and semantic behavior of verbs can be attributed to parametric variations in the verbalizing heads and the way meanings are packaged into roots.

The central thesis of this work is that argument structure can be reduced to a syntactically-encoded lexical semantic representation based on the structure of events, and that verb meanings are constructed from a combination of functional elements (verbalizing heads) and abstract concepts (categoryless verbal roots). Furthermore, this process of event composition is constrained by independently-motivated principles of syntax.

Mandarin lacks the adjective/verb distinction, and there is evidence that change of state predicates derive from underlying stative verbs :

- (2) a. *shu₄ gao₁ shi₂ gung₁fen₁*
 tree tall ten centimeter
 ‘The tree is ten centimeters tall.’ (e.g., a bonsai tree)
- b. *shu₄ gao₁ le₅ shi₂ gung₁fen₁*
 tree tall _{LE} ten centimeter
 ‘The tree grew ten centimeters.’

The above minimal pair suggests that the particle *le* contributes the semantic function of inchoativity, deriving a change of state from a state. Based on evidence such as this minimal pair, I will show in the next chapter that verbal *le* does indeed signal inchoativity.

The derivation of Mandarin change of state predicates shows superficial similarities to deadjectival verbs in English:

- (3) a. The tire is flat.
 b. The tire flattened.
 c. John flattened the tire.

Derivational suffixes in English such as *-en*, *-ify*, and *-ize* transform adjectives into change of state verbs. These verbs can typically undergo further causativization and appear in a transitive sentence, as in (3c).

The ability of deadjectival verbs to appear both transitively and intransitively is related to the well-studied causative/inchoative alternation:

- (4) a. John destroyed/broke the window.
 b. The window *destroyed/broke.
- (5) a. John pushed/toppled the stack.
 b. The stack *pushed/toppled.

In English, the verbs *break* and *topple* can be used both as a transitive and intransitive verb, whereas *destroy* and *push* can only be used transitively. Since both verbs in the pair can conceivably be used to describe the same event, the differences between them cannot lie in the nature of the events they denote, but rather must be attributed to the particular way in which events are represented linguistically.

In this alternation, the transitive version of the verb almost always means “to cause to *V*-intransitive”. Alternating verb pairs denote two different types of events: one which merely specifies a change of state, and another which explicitly attributes a cause to the change of state. It is also worthwhile to note that the object of the causative variant bears the same semantic role to the verb as the subject of the inchoative variant. A theory of verbal argument structure must, at the very least, explain these empirical facts. It must also explain the derivational relationship between the causative and inchoative alternants in a way that is consistent with morphological differences between the verb pairs—in many languages, one form of the verb is morphologically distinct from the other form.

Not surprisingly, valency alternations of the same type also exist in Mandarin:

- (6) a. *shu*₄ *dao*₃ *le*₅
 tree fall LE
 ‘The tree fell.’
- b. *Zhang*₁ *san*₁ *(*kan*₃) *dao*₃ *le*₅ *shu*₄
 Zhangsan chop fall LE tree
 ‘Zhangsan chopped the tree down.’

Whereas in English the inchoative form of the verb can freely causativize without any overt change (morphological or otherwise)¹, Mandarin change of state predicates

¹I will argue in Chapter 2 that this is indeed the direction of derivation; Section 3.9 will specifically highlight the problems with the alternative analysis: deriving inchoatives from causatives.

generally cannot take an external argument directly. Instead, speakers must use a resultative verb compound (RVC) to convey the intended meaning. Typically, the first verb in the compound denotes an activity, and the second verb denotes the end state that results from the activity. The formation of resultative verb compounds in Mandarin is a productive process—the only constraint on verb combinations appears to stem from plausible real-world associations between a causing activity and a direct result (a more thorough analysis of these constraints will be taken up in Chapter 3). The following shows a small range of possible resultative verb compounds with the *dao*₃ ‘fall’ result:

- | | | | |
|-----|--------------------------------------|------------|----------------------|
| (7) | kan ₃ dao ₃ | chop-fall | <i>to chop down</i> |
| | zhuang ₄ dao ₃ | crash-fall | <i>to knock over</i> |
| | tui ₁ dao ₃ | push-fall | <i>to push over</i> |
| | la ₁ dao ₃ | pull-fall | <i>to pull down</i> |

In Mandarin, why can’t most change of state predicates directly causativize? What governs the process by which a monomorphemic verb becomes a verbal compound? By hypothesis, both Mandarin and English share the same inventory of primitive building blocks, and are governed by the same set of constraints on constructing linguistic representations—all endowed by principles of Universal Grammar. Yet, Mandarin and English appear, at least superficially, to employ very different processes for composing complex events. This is not the only troubling issue: whereas Mandarin uniformly encodes all states as verbs, states in English are either verbs (e.g., *know*, *love*, *believe*) or adjectives (e.g., *flat*, *tall*, *cool*), or are morphologically complex (e.g., *broken*, *sunken*, *frozen*). How can these cross-linguistic differences be accounted for in a unified theory of argument structure? I believe that my theory sheds insight on these important questions.

My exploration of these topics will have the following organization: First, an overview of previous approaches to verbal argument structure will be presented. Following that, I will set forth my own theory, describing my hypothesized inventory of primitive building blocks and how they compose in the syntax. I will then present evidence from Mandarin for my analysis: it will be shown that the organization of the Chinese verbal system parallels my framework of verbalizing heads and verbal roots in a fairly transparent manner. To study the process of complex event composition in greater detail, I will take a closer look at resultative verb compounds in Mandarin, from both a typological and syntactic viewpoint. I will highlight the dimensions of variation for these verbal compounds and present a syntactic analysis that adequately captures these variations. The final part of this work is devoted to the issue of cross-linguistic variation, and what makes English look so different from Mandarin. In particular, I will explore a semantic property of stative roots and how it interacts with the verbalizing heads to give rise to cross-linguistic surface difference.

This work is primarily concerned with the encoding of a verb’s internal arguments, which are traditionally thought of as being directly licensed within the domain of the verb phrase. Internal arguments, however, can appear as the subject of a sentence (in the case of unaccusatives) or the object (in the case of causatives and ergatives).

Despite the empirical coverage of my theory, there is a wide range of interesting phenomena that is beyond the scope of this work. Most conspicuously missing is the treatment of so-called applicative constructions, often informally known by labels such as goal, possessor, experiencer, benefactive, and malefactive, among other names. Some aspects of causation, for example, the causativization of prototypical unergative verbs such as *smile* and *run*, will only be discussed in passing (this process is productive neither in Mandarin nor in English). My work mostly focuses on the “inchoative core” of a verb—how change of state meanings derive from underlying states, and how this component interacts with activities. However, others have developed theories similar in spirit to mine that address the licensing of subjects/causation (Harley, 1995; Pykkänen, 2002) and dative/applicative arguments (Pykkänen, 2002; Cuervo, 2003); their proposals could quite easily be adapted into my framework.

1.1 From Semantic Roles to Event Structure

1.1.1 Semantic Roles

The earliest formulation of the constraints that govern argument realization involves generalized collections of semantic (thematic) roles, known as a *case frame* (Fillmore, 1968) or a *theta-grid* (Stowell, 1981) under the framework of Government and Binding Theory. The idea of semantic roles was first explicated in Fillmore’s seminal paper, “The Case for Case” (1968), which argues that the propositional component of a sentence can be represented as an array consisting of the verb and a number of noun phrases specifically marked with roles such as *agent*, *patient*, *instrument*, and *goal*. These labels identify the grammatically relevant aspects of the roles that pertain to argument realization in the syntax. A verb is defined by the semantic roles that it “takes”, i.e., its case frame. For example, *kick* takes an agent and a patient, while *frighten* takes an experiencer and a stimulus.

A fundamental assumption behind this lexicalist approach is that argument structure is directly determined by the lexical properties of predicates. In other words, the lexical entry of a verb directly determines its syntactic behavior. Chomsky’s (1981) Projection Principle is a good example of this idea. In the context of Relational Grammar, Perlmutter and Postal propose following:

(8) *Universal Alignment Hypothesis (UAH)*

There exist principles of UG which predict the initial relation borne by each nominal in a given clause from the meaning of the clause.

(Perlmutter and Postal, 1984:97)

Baker argues that the mapping between semantic arguments (i.e., thematic roles) and syntactic positions is universal, and determined by the meaning of individual verbs:

(9) *Uniformity of Theta Assignment Hypothesis (UTAH)*

Identical thematic relationships between items are represented by identical structural relationships between those items at the level of D-Structure.
(Baker, 1988:46)

Fillmore's Case Grammar was originally designed to address argument realization patterns typical in English such as those illustrated in (10).

- (10) a. John opened the door with the key.
b. The key opened the door.
c. The door opened.

In (10a), *John*, the agent, is linked to the grammatical subject; *the door*, the patient, is linked to the direct object; *the key*, the instrument, is linked to an oblique prepositional phrase headed by *with*. In (10b), the agent role is missing, and in its place, the instrument manifests as the grammatical subject. In (10c), only the patient is present, and is linked to the subject position.

A central assumption underlying Case Grammar is that a relatively small inventory of semantic roles is sufficient to describe the grammatically-relevant aspects of arguments. It is also believed that a small number of universal "linking rules" can capture the myriad of ways semantic arguments can be expressed in the surface form of an utterance. More concretely, Fillmore posits rules like the following to account for alternations observed with verbs such as *open*:

- (11) If there is an A [Agentive], it becomes the subject; otherwise, if there is an I [Instrumental], it becomes the subject; otherwise, the subject is the O [Objective]. (Fillmore, 1968:33)

This general approach of formulating linking rules in terms of thematic roles has been significantly elaborated in the theory of thematic hierarchies (Jackendoff, 1972), following the UTAH. Under this approach, thematic roles are arranged in an abstract "prominence" hierarchy, and the realization of syntactic arguments is based on the position of roles in this hierarchy. The highest role in thematic hierarchy is assigned the highest argument in the syntactic structure (the subject), the next highest role is assigned the next highest argument, and so forth. Thematic hierarchies are considered to be an independent and irreducible module of grammar. A few examples are given below:

- (12) Agent > Dative/Benefactive > Patient > Location >
Instrumental/Associative > Manner
(Givón, 1984:139)

- (13) Agent > Beneficiary > Recipient/Experiencer > Instrument > Theme/Patient
> Location
(Bresnan and Kanerva, 1989:23)

(14) Actor > Patient/Beneficiary > Theme > Location/Source/Goal
(Jackendoff, 1990:258)

(15) Agent > Effector > Experiencer > Locative/Recipient > Theme > Patient
(Van Valin, 1993:75)

Psych verbs, which describe psychological states, are problematic for theories of argument structure based on thematic hierarchies. Such verbs typically take two roles, *experiencer* and *theme*, the assignment of which violates any possible role ordering:

- (16) a. John's comments worried Mary.
b. Mary worried about John's comments.

The experiencer can either appear in the subject or object position, apparently violating the UTAH. Belletti and Rizzi (1988) argue, however, that both sentences in (16) share the underlying structure. More recently, Pesetsky (1995) refutes their analysis, once again casting doubt on the validity of thematic hierarchies.

Even disregarding psych verbs, there is still considerable debate over the ordering of roles in thematic hierarchies. Although there is consensus that agent is the most prominent role, little agreement has been reached beyond that. In fact, the actual inventory of semantic roles, along with precise definitions and diagnostics, remains an unsolved problem. These are not the only drawbacks associated with theories of argument structure that rely on semantic roles:² Some analyses show that semantic roles are too coarse-grained to account for certain semantic distinctions. The only recourse, to expand the collection of roles, comes with the price of increased complexity, e.g., in the linking rules. Fillmore's original assumption that each noun phrase in an utterance occupies a unique thematic role is often called into question. For some verbs, e.g., *resemble*, multiple noun phrases appear to have the same role. For other verbs, the internal argument does not appear to bear any natural semantic role, e.g., *praise*, *imagine*, and *promise*.

Finally, because case frames are "flat", i.e., lacking any internal structure, a theory based purely on semantic roles is primarily descriptive. Such accounts, for example, do not make strong predictions regarding the range of possible and impossible verbs. Why is it, for example, that *kick* takes an obligatory agent and an obligatory patient? Why is the instrument in *open* optional? Fundamentally, semantic role theories cannot offer satisfactory answers to these questions because they do not directly refer to the meaning of verbs and the events they denote.

An alternative to thematic hierarchies is Dowty's (1991) proto-role approach. He argues that agent and patient are the only two semantic roles relevant for argument realization. Furthermore, these two roles are merely prototypes for a conceptual space of properties; hence, *proto-agent* and *proto-patient*. The thematic role of an argument can be reduced to lexical entailments imposed on it by the verb, but no single property is either necessary or sufficient. The main proto-agent and proto-patient entailments given by Dowty (1991:572) are listed below:

²See Dowty (1991) and Levin and Rappaport Hovav (1996) for detailed criticisms.

- (17) Proto-Agent entailments:
- a. volitional involvement in the event or state
 - b. sentience and/or perception
 - c. causing an event or change of state in another participant
 - d. movement (relative to the position of another participant)
 - e. referent exists independent of action of verb
- (18) Proto-Patient entailments:
- a. undergoes change of state
 - b. incremental theme
 - c. causally affected by another participant
 - d. stationary relative to movement of another participant
 - e. does not exist independent of the event, or not at all

To determine the realization of arguments, Dowty suggests a simple “counting up” algorithm:

(19) *Verbal Argument Selection Principle*

In predicates with grammatical subject and object, the argument for which the predicate entails the greatest number of Proto-Agent properties will be lexicalized as the subject of the predicate; the argument having the greatest number of Proto-Patient entailments will be lexicalized as the direct object. (Dowty, 1991:576)

The assumption behind this approach is that each lexical entailment is equally important, and that there is no precedence relationship between the properties. Although Levin and Rappaport Hovav (1995) present some evidence that linking rules are ordered, at least partially, nothing in Dowty’s theory precludes such a modification (for example, assigning certain entailments higher weights).

The empirical coverage of Dowty’s theory is impressive; his proto-agent and proto-patient properties capture important generalizations about the realization of arguments. The theory, however, is descriptive in that it leaves open the question of where these lexical entailments come from.

Recognizing the drawbacks of theories based purely on semantic roles, there is now a general consensus among linguists that argument structure is (to a large extent) predictable from event semantics—hence, patterns of argument realization should be inferable from lexical semantic representations grounded in a theory of events. The next section reviews work on event ontologies and the classification of events into aspectual classes, which serves as a foundation for many event-based theories of lexical semantic representation.

1.1.2 Event Types and Lexical Semantics

Although Aristotle (*Metaphysics 1048b*) observed that the meanings of some verbs involve an “end” or a “result”, and others do not, it wasn’t until the twentieth century that philosophers and linguists developed a classification of event types that accurately captures logical entailments and the co-occurrence restrictions between verbs and other syntactic elements such as tenses and adverbials.

Drawing from the work of Ryle (1949) and Kenny (1963), Vendler (1957; 1967) first proposed a four-way classification of events into states, activities, accomplishments, and achievements based on the aspectual properties of verbs (see Dowty, 1979 for a thorough review and related discussions). Examples of the four event types are given below (from Dowty, 1979:54):

	<i>States</i>	<i>Activities</i>	<i>Accomplishments</i>	<i>Achievements</i>
	know	run	paint a picture	recognize
(20)	believe	walk	make a chair	find
	have	swim	deliver a sermon	lose
	desire	push a cart	draw a circle	reach
	love	drive a car	recover from illness	die

It is important to note that Vendler’s use of aspectual properties to classify events refers to *lexical aspect*, sometimes called *aktionsart*. In the vocabulary of Smith (1991), the Vendlerian event ontology refers to *situational aspect*, which is contrasted with *viewpoint aspect* (notions such as perfective and imperfective).

Under Vendler’s classification, activities and states both depict situations that are inherently temporally unbounded (atelic); states denote static situations, whereas activities denote on-going dynamic situations. Accomplishments and achievements both express a change of state, and hence are temporally bounded (telic); achievements are punctual, whereas accomplishments extend over a period of time. For expository convenience, I will collectively refer to accomplishments and achievements as change of states, and following the literature, I will use eventuality (Bach, 1981) as the cover term for all four event types. Although activities group naturally with states and accomplishments with achievements in terms of telicity, it has also been observed that states can be grouped with achievements and activities with accomplishments in that the first pair lacks the progressive tense, while the second pair allows them (cf. Lakoff, 1966; Shi, 1988). To capture these properties, Vendler’s classes can be further decomposed in terms of independent features (cf. Andersen, 1990; Smith, 1991:30; Van Valin and LaPolla, 1997:91-102):

- (21)
- a. States: [–telic, –durative, –dynamic]
 - b. Activities: [–telic, +durative, +dynamic]
 - c. Achievements: [+telic, –durative, +dynamic]
 - d. Accomplishments: [+telic, +durative, +dynamic]

Although properties of Vendler’s event types can be captured by the above features, the linguistic reality of achievements has been questioned by many linguists.

They are punctual and telic by definition, but it is unclear whether the duration is a property inherent to the verb, or the result of real-world, extra-linguistic knowledge. For example, Pustejovsky (1991) collapses accomplishments and achievements into what he calls “transitions”. Tenny (1987:20) similarly contends that achievements and accomplishments are the same, modulo the duration of the event. Verkuyl (1993:48) considers the verb *type*, as in “to type a letter”: is it an achievement? One can imagine such an event having a long duration (typing a long correspondence), or being punctual (typing the letter *a*). Verkuyl concludes that the duration of events, and hence the distinction between achievements and accomplishments, is a matter of real-world knowledge. Although I share this sentiment, evidence from Mandarin suggests that, at least for some predicates, achievement is directly encoded in the meaning of a verb. In this work, where the duration of an event is irrelevant, I will employ the more general cover term change of state.

Nevertheless, Vendler’s ontology of event types serves as a foundation upon which others have grounded lexical semantic representations and theories of verbal argument structure. In Dowty’s seminal work (1979), he attempts to decompose states, activities, accomplishments, and achievements in terms of the primitives DO, CAUSE, and BECOME:

- (22) a. state: $\pi_n(\alpha_1, \dots, \alpha_n)$
 b. activity: $\text{DO}(\alpha_1, [\pi_n(\alpha_1, \dots, \alpha_n)])$
 c. achievement: $\text{BECOME}[\pi_n(\alpha_1, \dots, \alpha_n)]$
 d. accomplishment: $[[\text{DO}(\alpha_1, [\pi_n(\alpha_1, \dots, \alpha_n)])] \text{CAUSE} [\text{BECOME} [\pi_n(\alpha_1, \dots, \alpha_n)]]]]$
 (Dowty, 1979:123-124)

Examples of Dowty’s analysis applied English sentences are shown below:

- (23) a. He sweeps the floor clean.
 $[[\text{DO}(he, \text{sweeps}(the \text{ floor}))] \text{CAUSE} [\text{BECOME} [\text{clean}(the \text{ floor})]]]]$
 b. John walks.
 $[\text{DO}(John, \text{walk})]$

In what later becomes a standard analysis adopted by subsequent linguists, Dowty breaks causative sentences down into two subevents: a causing subevent and a result subevent. The representation of the resultative sentence (23a) is comprised of the causing subevent “he sweeps the floor” and the result subevent “the floor is clean”. Unergative verbs, on the other hand, are represented by a single subevent with the primitive DO.

More recently, Rappaport Hovav and Levin’s (1998) theory of event templates also defines a basic inventory of event building blocks in terms of Vendler’s event types:

- (24) a. $[x \text{ACT}_{\langle \text{MANNER} \rangle}]$ (activity)
 b. $[x \langle \text{STATE} \rangle]$ (state)

- c. [BECOME [x <STATE>]] (achievement)
- d. [x CAUSE [BECOME [y <STATE>]]] (accomplishment)
- e. [[x ACT_{<MANNER>}] CAUSE [BECOME [y <STATE>]]]
(accomplishment)

(Rappaport Hovav and Levin, 1998:108)

A verb's meaning consists of an association between a constant and an event template from the above inventory. Constants are open-class items drawn from a fixed ontology (e.g., manner, instrument, state, etc.) and are represented within the angle brackets of the event template. Each constant is also associated with a name (i.e., a phonological string). A set of "canonical realization rules" governs the compatibility of different constant types with different event types:

- (25)
- a. manner \rightarrow [x ACT_{<MANNER>}]
(e.g., *jog*, *run*, *creak*, *whistle*, etc.)
 - b. instrument \rightarrow [x ACT_{<INSTRUMENT>}]
(e.g., *brush*, *hammer*, *saw*, *shovel*, etc.)
 - c. placeable object \rightarrow [x CAUSE [BECOME [x WITH <THING>]]]
(e.g., *butter*, *oil*, *paper*, *tile*, *wax*, etc.)
 - d. place \rightarrow [x CAUSE [BECOME [x <PLACE>]]]
(e.g., *bag*, *box*, *cage*, *crate*, *garage*, *pocket*, etc.)
 - e. internally caused state \rightarrow [x <STATE>] (state)
(e.g., *bloom*, *blossom*, *decay*, *flower*, *rot*, *rust*, *sprout*, etc.)
 - f. externally caused state \rightarrow
[[x ACT] CAUSE [BECOME [y <STATE>]]]
(e.g., *break*, *dry*, *harden*, *melt*, *open*, etc.)

(Rappaport Hovav and Levin, 1998:109)

An important claim of this theory is that verbs directly project (encode, or lexicalize) complex event structures. This marks a critical difference between my theory and that of Rappaport Hovav and Levin, which is lexicalist in the sense that verbs introduce completely well-formed lexical semantic representation into the syntactic derivation process. In contrast, I will argue that event and argument structure is itself composed in the syntax.

To account for complex events and secondary predication, Rappaport Hovav and Levin propose a process called *Template Augmentation* that allows basic event templates to be freely "augmented" to any other event template.³ This process, for example, accounts for the resultative form of surface contact verbs such as *sweep*, shown in (26b). In this case, an activity has been augmented into an accomplishment through the addition of another subevent, i.e., the floor becoming clean (note similarities with Dowty's representation).

³See (Washio, 1997) for a discussion about problems associated with such an account of secondary predication.

- (26) a. Phil swept the floor.
 [Phil ACT_{<SWEEP>} floor]
 b. Phil swept the floor clean.
 [[Phil ACT_{<SWEEP>} floor] CAUSE
 [BECOME [floor <CLEAN>]]]

In order to map arguments in the lexical semantic representation to syntactic arguments, Rappaport Hovav and Levin posit a linking theory consisting of a number of rules and well-formedness conditions on the event representation (more on this in Section 1.1.4).

The biggest problem with attempting to align lexical semantic representations with aspectually-defined event types is that Vendler’s classification does not directly apply to a verb in isolation, but is rather a property of the entire verb phrase (or perhaps even the entire utterance). The influences of direct objects, adjuncts, and even subjects must be factored in with the inherent properties of a verb in order to arrive at an event classification—in both Dowty’s and Rappaport Hovav and Levin’s framework, these effects are not properly captured within the event representation.

Many linguists have noticed, for example, that certain direct objects, particularly those of creation/consumption verbs (so-called *incremental theme objects*), can cause a verb to “shift” into different aspectual classes (Verkuyl, 1972; Dowty, 1979; Tenny, 1987; Verkuyl, 1995; Jackendoff, 1996, among others). For example, *eat*, which is atelic in isolation, becomes telic whenever the direct object is a count noun, but remains atelic when the direct object is a mass noun:

- (27) a. John ate the apple in an hour/*for an hour.⁴
 b. John ate pudding *in an hour/for an hour.

The verb *eat* is inherently an activity, and remains an activity with a mass noun direct object (27b), but becomes an accomplishment with a count noun direct object (27a). Although this is the conventional wisdom and standard analysis, I will argue in Section 2.3.2 that *eat* is an activity in both cases, and that the accomplishment reading arises from an implicature.

In addition to the count/mass distinction of incremental themes, real-world knowledge has a strong influence on telicity. Jackendoff (1996) offers the following examples:

- (28) a. John ate pudding. (activity)
 b. John ate the apple. (accomplishment)
 c. John ate the grape. (achievement)

⁴Note that “eating the apple *for an hour*” is acceptable only in the situation where John didn’t consume the entire apple, i.e. “John slowly ate the apple for an hour, but then he had to throw it away because his lunch break was over”. In general, *for X* is compatible with accomplishments, but gives rise to a different interpretation.

As previously discussed, (28a) denotes an activity because *pudding* is a mass noun. Because people usually eat apples one bite at a time, (28b) represents an accomplishment that takes place over time. However, since a grape is typically consumed in a single bite, (28c) denotes a punctual event, or achievement. In this case, we have the situation where an inherent activity verb may assume three different aspectual event types (or so it seems), based on semantic features of the direct object.

Adjuncts also play an important role in the calculation of an utterance's *aktionsart*. Consider verbs of sound emission and verbs of manner of motion, which are inherently activities, but become accomplishments with the addition of a goal prepositional phrase (cf. Levin and Rappaport Hovav, 1995).

- (29) a. The children splashed the water. (activity)
 b. The children splashed down the street. (accomplishment)
- (30) a. John swam. (activity)
 b. John swam across the pool. (accomplishment)
- (31) a. John pushed the cart. (activity)
 b. John pushed the cart down the street. (accomplishment)

Finally, it has not escaped the attention of linguists that the subject of a sentence also influences its aspectual interpretation. If an indefinite plural occurs as the subject of an achievement, the sentence is acceptable with durative adverbials (cf. Verkuyl, 1972; examples from Dowty, 1979:63):

- (32) a. *John discovered that quaint little village for years.
 b. Tourists discovered that quaint little village for years.

It is unclear how the representations proposed by Dowty, and Rappaport Hovav and Levin are able to account for the contributions of various sentential elements to lexical aspect—in general, they are unable to account for the temporal contour of events because their underlying predicates are (for the most part) atemporal in nature. It has recently been suggested, however, that the original goal of aligning lexical semantic representations (for the purpose of argument realization) with aspectual event types may have been misguided. Even though aspectual notions figure prominently in her own work on argument structure, Levin writes:

- (33) I suggest that it is right to ground lexical semantic representations in a theory of event structure, but that the ontological types of events relevant to argument realization may not all be aspectual in nature. (Levin, 2000)

Levin goes on to argue that notions relevant to argument realization traditionally tied to aspectual properties are, in fact, independent from them. Therefore, Vendler's event ontology may serve as a useful guide for lexical semantic representations, but may not be the final determinant of event-based theories of argument structure.

1.1.3 A Survey of Event Representations

In addition to the work of Dowty, and Rappaport Hovav and Levin, many theories of lexical semantic representations have been developed to address the well-known shortcomings of theories based-on semantic roles (for example, Carter, 1976; Jackendoff, 1983; Pinker, 1989; Parsons, 1990; Pustejovsky, 1991; Croft, 1998, just to name a few). The general spirit of the enterprise involves lexical semantic representations that decompose events into more primitive predicates; the semantic roles borne by various verb arguments can then be represented in terms of these event primitives. It is widely believed that a theory of argument structure organized around more abstract primitives would lead to a more compact framework with greater explanatory and predictive power.

Common to these decompositional theories are three components: a relatively small inventory of primitive predicates, typically drawn from ontological categories such as EVENT and represent conceptual notions such as CAUSE; a much larger collection of constants or open-class items; and a method of combining predicates with constants to create larger expressions (and rules governing the well-formedness of these expressions).

Carter

The work of Carter (1976) represents an early attempt at decomposing verbs in terms of primitives:

- (34) *darken*: x CAUSE ($(y$ BE DARK) CHANGE)
(Carter, 1976)

In (34), *darken* can be paraphrased as *cause to change into a state of being dark*. For Carter, primitives represent such notions as causation (CAUSE), stativity (BE), and inchoativity (CHANGE).

Jackendoff

A noteworthy decompositional theory of predicate argument structure is Jackendoff's (1983; 1990; 1991; 1996) Conceptual Semantics. Unique to his representation, Lexical Conceptual Structures (LCS), is the treatment of PATH as an ontological category, on par with EVENT, STATE, THING, and PLACE. Consider the following examples:

- (35) a. John ran into the room.
[_{Event} GO ([_{Thing} JOHN], [_{Path} IN([_{Thing} ROOM])])]

b. John put the vase on the table.
[_{Event} CAUSE(John, [_{Event} GO ([_{Thing} VASE], [_{Path} ON([_{Thing} TABLE])])])]

(Jackendoff, 1983, 1990)

The event in (35a) can be paraphrased as “John moved along a trajectory that terminates in the room”. The path structure can take other path primitives that denote features such as the source or the direction of travel. Similarly, the event in (35b) involves motion along a trajectory, this time externally caused by John.

Jackendoff’s work formalizes earlier insights of Gruber (1965), expressed in the Thematic Relations Hypothesis. The basic claim is that events involving motion, locations, and paths are fundamental to human cognition, and that the machinery used for analyzing these events are harnessed to support the comprehension of events in other “semantic fields” such as the temporal or possessive field. Jackendoff points out, for example, that paths in space parallel intervals in time:

- (36) a. at 6:00
 at the corner
 b. from Tuesday to Thursday
 from Denver to Indianapolis
 c. in 1976
 in Cincinnati
 d. on my birthday
 on the table

(Jackendoff, 1983:189)

Extending this intuition, Jackendoff analyzes states and change of states as location in and motion through an abstract “state space” (what he calls the identificational semantic field), respectively:

- (37) a. The light is red.
 $[\text{Event BE}_{\text{Ident}}([\text{Thing LIGHT}], [\text{AT}_{\text{Ident}}([\text{Property RED}]])]$
 a. The pages yellowed.
 $[\text{Event GO}_{\text{Ident}}([\text{Thing PAGES}], [\text{TO}_{\text{Ident}}([\text{Property YELLOW}]])]$

(Jackendoff, 1983:195)

An interesting consequence of Jackendoff’s analysis is that the BECOME primitive used by Dowty is “collapsed” into the primitive GO normally used to describe physical motion along a trajectory, i.e., change of state is viewed as metaphoric motion through state space. As Jackendoff (1990) himself noted later, this analysis does not appear to be correct. Consider the following sentence:

- (38) The weathervane pointed north.

There are two readings of this sentence, a stative one and a dynamic one, as in “A gust of wind made the weathervane point north”. The representations for both interpretations would be:

- (39) a. $[\text{State ORIENT}([\text{Thing WEATHERVANE}], [\text{Path NORTH}])]$

- b. $[_{\text{Event}} \text{GO}([_{\text{State}} \text{ORIENT}([_{\text{Thing}} \text{WEATHERVANE}], [_{\text{Path}} \text{NORTH}]])]$
 (Jackendoff, 1990:75,92)

But surely the representation in (39b) does not accurately capture the change of state reading of (38). With the GO function, the paraphrase of the representation would be something along the lines of “the weathervane traveled/moved northwards”, which is not an attested reading of the sentence. Thus, Jackendoff concludes that inchoativity cannot be reduced to metaphoric motion, and requires a separate primitive, which he calls INCH. In short, change of state and motion towards a state do not mean the same thing. It just so happens, however, that the meaning of GO overlaps with the meaning of INCH in the physical domain.

Based on these notions, Jackendoff analyzes verbs of creation in the following way:

- (40) John built the house out of bricks.
 $[_{\text{Event}} \text{CAUSE}(\text{John},$
 $[_{\text{Event}} \text{INCH}([_{\text{State}} \text{BE}_{\text{Comp}+} ([_{\text{Thing}} \text{HOUSE}], [_{\text{Path}} \text{FROM}([_{\text{Thing}} \text{BRICKS}]])])])]$
 (Jackendoff, 1990:120)

The subscript on the BE in (40) indicates that the event is to be interpreted in the semantic field of composition. In essence, the construction of the house can be analyzed in terms of a change of state in abstract “state space”.

In a subsequent refinement of his original conceptual structures, Jackendoff (1990) introduces a two-tiered analysis of argument structure, paralleling developments in phonology. In his revised representation, the *thematic tier* deals with motion and location, and the *action tier* handles Actor-Patient relations. The motivation for this split is the notion of “affected entity” and certain aspects of causation, which could not be adequately handled by his original proposals.

The primitive AFF (affect) is introduced to capture causal relationships between the actor and the patient; subscripts on AFF indicate volition or lack thereof ($[\pm\text{vol}]$). Consider the following example:

- (41) Bill rolled down the hill

$$\left[\begin{array}{l} \text{GO}([\text{BILL}, [\text{DOWN}[\text{HILL}]]]) \\ \left\{ \begin{array}{l} \text{a. AFF}_{+\text{vol}}([\text{BILL}],) \\ \text{b. AFF}_{-\text{vol}}([\text{BILL}],) \\ \text{c. AFF}(, [\text{BILL}]) \end{array} \right\} \end{array} \right]$$

 (Jackendoff, 1990:129)

There exist three readings for the sentence in (41): Bill as the “willful doer” (41a), “nonwillful doer” (41b), and “undergoer” (41c). Jackendoff argues that a two-tiered analysis of event structure is necessary to capture subtle distinctions in meaning relevant to argument realization.

Parsons

Integrating Davidson’s hypothesis (1967) that representation of sentences contain explicit reference to events variables with aspects of Dowty’s more fine-grained analysis, Parsons presents a representation of English sentences grounded in an ontology of events much like Vendler’s. Although Parson’s theory was not designed to address issues surrounding the realization of verb arguments, his work is nevertheless interesting and relevant to this present work. Schematically, Parsons’ representation for a sentence is shown below:

$$(42) \text{Verb}(e) \wedge \text{Role}(e, x)^n \wedge \text{Mod}(e)^m \wedge \text{Cul}(e, t)$$

(Parsons, 1990:208)

The verb introduces an event and other sentential elements are represented as separate conjuncts related to the verb through the event argument. $\text{Role}(e, x)$ refers to one or more conjuncts that relate entities to the verb via thematic roles (agent, theme, etc.); $\text{Mod}(e)$ refers to one or more conjuncts that arise from adverbial modifiers; $\text{Cul}(e, t)$ refers to the culmination of the event with respect to some reference time. The representation of the sentence “Brutus stabbed Caesar violently” would be:

$$(43) \exists I[I < \text{now} \wedge \exists e \exists t[t \in I \wedge \text{Stabbing}(e) \wedge \text{Agent}(e, \text{Brutus}) \wedge \text{Theme}(e, \text{Caesar}) \wedge \text{Violent}(e) \wedge \text{Cul}(e, t)]]$$

Abstracting away from tense, here are some examples of Parson’s representation for more complex sentences:

$$(44) \text{ a. } x \text{ closes the door}$$

$$(\exists e)[\text{Cul}(e) \wedge \text{Agent}(e, x) \wedge (\exists e')[\text{Cul}(e') \wedge \text{Theme}(e', \text{door}) \wedge \text{CAUSE}(e, e') \wedge (\exists s)[\text{Being-closed}(s) \wedge \text{Theme}(s, \text{door}) \wedge \text{Hold}(s) \wedge \text{BECOME}(e', s)]]]]$$

(Parsons, 1990:120)

$$\text{ b. } x \text{ hammered the metal flat}$$

$$(\exists e)[\text{Cul}(e) \wedge \text{Agent}(e, x) \wedge \text{Hammering}(e) \wedge \text{Theme}(e, \text{metal}) \wedge (\exists e')[\text{Cul}(e') \wedge \text{Theme}(e', \text{metal}) \wedge \text{CAUSE}(e, e') \wedge (\exists s)[\text{Being-flat}(s) \wedge \text{Theme}(s, \text{metal}) \wedge \text{Hold}(s) \wedge \text{BECOME}(e', s)]]]]$$

(Parsons, 1990:122)

Parsons adopts Dowty’s bi-eventive analysis of causatives containing a causing subevent and a result subevent. Although the two frameworks share a number of common aspects, a major contribution of Parsons is the introduction of event variables as an integral part of the lexical semantic representation. This device allows the representation to compactly capture proper logical entailments and correctly handle anaphoric event references in English.

Croft

Another, quite different, approach to event structure is to focus on causal relations between participants in the events. Croft (1991; 1998), drawing inspiration from Talmy’s work on force dynamics (1976; 1988), models events as a non-branching causal chain composed of distinct segments—his representation of events is actually geometric in nature. Each segment in the causal chain represents a simple event involving an asymmetric transfer of force. Consider the classical example of the prototypical transitive verb *break* whose event structure can be broken into a three-link causal chain:

- (45) John broke the window.
- i. John acted on the window. (CAUSE)
 - ii. The window changed state. (CHANGE)
 - iii. The window broke. (STATE)

The actual realization of arguments is dependent on the verb “profile”, or the segments of the casual chain that the verb describes. Causal segments directly profiled by the verb contain the verb’s semantic arguments; other segments may still be realized in the utterance, but only as adjuncts. In terms of the causal chain and the verb profile, Croft formulates four linking rules:

- (46)
1. The verbal profile is delimited by Subject and Object.
 2. Subject > Object
 3. Antecedent Oblique > Object > Subsequent Oblique
 4. Subject > Incorporated Noun > Object (if any)

$x > y = 'x \text{ antecedes } y \text{ in the force-dynamic chain}'$

(Croft, 1998:24)

The concept of causal chains and the linking rules correctly predict the realization of *John* as the subject and *the window* as the object in (45). However, the generality of Croft’s approach has been questioned for verbs that do not involve any transfer of force, e.g., unergatives and verbs of perception. Furthermore, one could perhaps argue that Croft’s approach is but a refined special case of Dowty’s proto-agent and proto-patient entailments.

1.1.4 From Linking Theory to Syntactic Representations

The works of Rappaport Hovav and Levin, Jackendoff, Croft, and many others assume a lexical semantic representation independent of syntactic structure.⁵ As such, these theories of verbal argument structure are incomplete without a (presumably

⁵Dowty’s work is in the Generative Semantics tradition, and Parsons’ theory makes no explicit reference to syntactic structures.

independent) component that explicitly maps between arguments in the event representation and arguments in the syntactic structure, i.e., a linking theory. Jackendoff uses a thematic hierarchy to mediate between semantic arguments and positions in the syntactic structure. Rappaport Hovav and Levin define a set of well-formedness constraints such as the Argument-Per-Subevent Condition (Rappaport Hovav and Levin, 1998; Levin, 2000) that associate pieces of event structure with syntactic structure. Furthermore, they propose the following four linking rules:

- (47)
- a. *Immediate Cause Linking Rule*. The argument of a verb that denotes the immediate cause of the eventuality described by that verb is its external argument.
(Levin and Rappaport Hovav, 1995:135)
 - b. *Directed Change Linking Rule*. The argument of a verb that corresponds to the entity undergoing the directed change described by that verb is its internal argument.
(Levin and Rappaport Hovav, 1995:146)
 - c. *Existence Linking Rule*. The argument of a verb whose existence is asserted or denied is its direct internal argument.
(Levin and Rappaport Hovav, 1995:153)
 - d. *Default Linking Rule*. An argument of a verb that does not fall under the scope of any of the other linking rules is its direct internal argument
(Levin and Rappaport Hovav, 1995:154)

The independent status of a compositional (and recursive) semantic representation that parallels syntactic structure has been questioned, and violates an assumption held by many linguists that syntax is the only generative system of the human language faculty. Furthermore, assuming this parallel representation architecture necessitates a theory of linking that itself needs to be independently motivated. Otherwise, linking rules would deteriorate into a collection of stipulative rules whose purpose is to merely bring event structure into alignment with syntactic structure. Positing an independent level of semantic representation essentially adds an “extra degree of freedom” in formulating theories of argument structure—freedom that if not properly constrained will result in arbitrary stipulations.

A potential solution to the challenges presented by an independent event representation is to simply assume that event structure *is* syntactic structure. This dramatically simplifies a theory of argument structure: it would eliminate the need for both an independent lexical semantic representation and a linking theory—argument structure, syntactic structure, and event structure would all be the same. The advantages that this assumption offers makes it a very attractive working hypothesis. Although many linguists have recently explored this line of inquiry (Hale and Keyser, 1993; Marantz, 1997; Borer, 2001, among many many others), the earliest form of such theories can be traced back to the Generative Semantics tradition, which maintained that Deep Structure directly encodes “meaning” (McCawley, 1968; Postal, 1970; Lakoff, 1971). As an example, McCawley (1968) represents the meaning of *kill* with a subtree that encodes “cause become not alive”:

(48) kill:

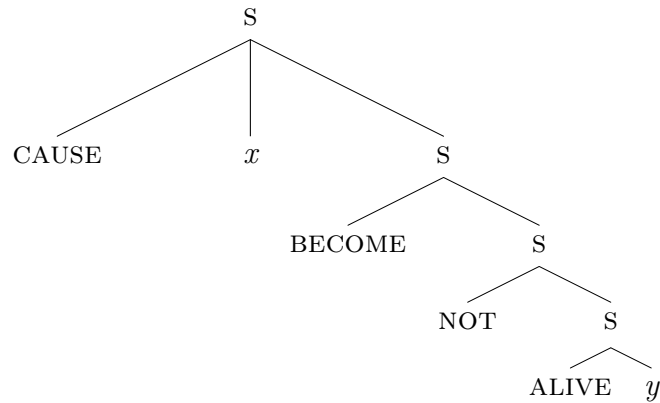

(McCawley, 1968, Figure 3)

The biggest problem with Generative Semantics work is that constraints in the composition of primitives are semantic, not syntactic, in nature. Thus, many studies from that era merely amounted to paraphrasing sentences with tree-like structures.

More recently, the work of Hale and Keyser (1993; 1998; 1999a; 1999b; 2002) is seminal with respect to the syntactic encoding of event structure. Their theory attempts to reduce thematic roles to syntactic configurations that lexical items and other functional elements participate in. They conceive of argument structure as “the syntactic configuration projected by a lexical item. Argument structure is the system of structural relations holding between heads (nuclei) and the arguments linked to them” (Hale and Keyser, 1999b:453).⁶ Limitations on the possible range of argument structures follows from independently-motivated syntactic principles (as opposed to the semantic relation between primitives). Technically, this is accomplished by extending Larson’s (1988) VP-shell analysis:

(49) The cook thinned the gravy.

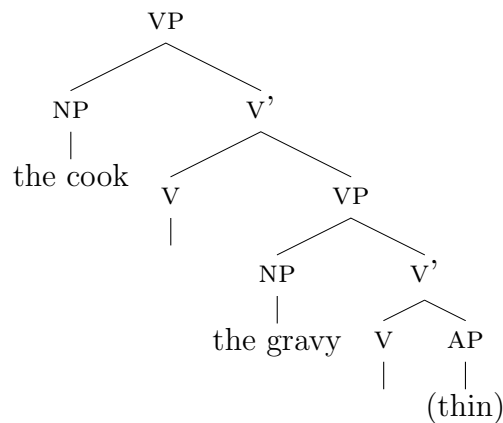

(Hale and Keyser, 1993:72)

The outer VP (in more recent terminology, *v*P) denotes an agentive, dynamic event that is in a causal relation with the inner VP, which also expresses a dynamic

⁶For more discussion on the homomorphic nature between syntactic and semantic structures, see (Bouchard, 1995; Baker, 1997).

event. The AP denotes the state achieved by the inner event, and its specifier, *the gravy* is identified as the theme/patient—the entity undergoing the change of state. Similarly, the outer VP identifies its specifier as the agent. In this manner, Hale and Keyser reduce thematic roles, considered by many to be an independent component of grammar, to canonical readings that listeners assign to specific structural configurations.

The final surface form of a sentence is derived through a series of head movements whereby the phonological content of the adjective (*thin*) ends up in the position of the outer V. In later versions of the theory, however, Hale and Keyser abandon the head movement analysis in favor of a “conflation” treatment (2000; 2002), which they argue to be a concomitant of the fundamental structure building operation MERGE (Chomsky, 1995).

Another noteworthy line of work that decomposes events in the syntax employs functional projections that are aspectual in nature (Borer, 1994; Ritter and Rosen, 1998; Ramchand, 1998; Ritter and Rosen, 2001; Ramchand, 2001, 2003). In Ritter and Rosen’s (2001) work, for example, canonical events are taken to consist of initiation, duration, and termination (van Voorst, 1986), each of which is directly licensed by an aspectual projection. It is unclear, however, whether semantic notions relevant to argument structure such as causation and inchoativity can be reduced to aspectual notions; see Levin (2000) for discussion on the relationship between aspect and lexical semantic representations. She argues, for example, that causation and telicity are independent concepts; therefore, analyses based purely on aspectual notions will have difficulty accounting for causal relations. I take the view that aspectual projections form a layer of syntactic representation above the functional elements responsible for argument and event structure.

1.2 Framing a Theory of Argument Structure

Implicit in the theory advocated by Hale and Keyser is that the head of each VP represents a conceptual primitive, e.g., notions such as agentivity and inchoativity. My theory of argument structure follows this tradition, but I render explicit the semantics of these verbalizing heads, which, by hypothesis, correspond to semantic primitives drawn from a conceptual inventory determined by Universal Grammar.

In addition, my theory assumes the framework of Distributed Morphology (Halle and Marantz, 1993, 1994; Marantz, 1997). It is argued that syntax does not manipulate full lexical items containing syntactic, semantic, and phonological information, but rather abstract bundles of morphosyntactic (and semantic) features that are relevant to the derivation process. Under the principle of “Late Insertion”, phonological material is inserted into the terminal nodes only at the perceptual/articulatory interface (PF) through insertion rules that pair a phonological signal with an insertion context (specified in terms of features).

Distributed Morphology abandons the distinction between syntactic derivation and morphological derivation, taking seriously the assumption that syntax is the single generative engine of the human language faculty. Thus, there is no Lexicon in the

traditional sense—the functions previously assigned to it are now distributed throughout various other components. It is therefore meaningless to talk about separate lexical processes, morphological processes, and syntactic processes because Distributed Morphology assumes a uniform substrate on which all derivation occurs. I believe that this framework constrains theories of argument structure and leads to more rigorous formulations. Earlier work in lexical semantics often appeal to notions such as “lexical rules”, or “it happens in the Lexicon”, which merely pushes the problem off to another (less-studied) component of grammar. An explanatory theory should, among other things, explicate the relationship between so-called lexical processes and other more familiar morphosyntactic processes. Distributed Morphology provides the theoretical substrate for accomplishing exactly that.

Based on the work of Marantz (1997), I take “verbs” as abstract categoryless concepts (verbal roots) that gain their verbal categorial status by association with a verbalizing head, drawn from an inventory of conceptual primitives shared by all languages. These verbalizing heads, or event introducers, license ontological event types that eventually give rise to classifications such as Vendler’s aspectual classes. Verbal roots serve as event modifiers that elaborate on the basic eventive readings introduced by the verbalizing heads. I posit an inventory of three such elements:

- (50) v_{DO} [+dynamic, –inchoative] = DO (introduces activities)
 v_{δ} [+dynamic, +inchoative] = BECOME (introduces change of states)
 v_{BE} [–dynamic] = BE (introduces states)

v_{DO} , v_{δ} , v_{BE} represent the notions of activity, inchoativity, and stativity, respectively. In addition, I posit two ontological types of verbal roots, similar to Rappaport Hovav and Levin’s template constants:

- (51) state: [*state* flat], [*state* break],⁷ [*state* red], etc.
activity: [*activity* run], [*activity* laugh], [*activity* dance], etc.

At this point, it is worthwhile to explicitly address two issues:

- (52) a. Why decompose verbs into verbalizing heads and roots?
b. Why this particular inventory of verbalizing heads?

The insight behind analyzing verbs in terms of roots and verbalizing heads stems from a distinction Grimshaw (1993) draws between *semantic structure* and *semantic content*. Semantic structure is the structural (configurational) component of verb meaning that is relevant for argument realization. Descriptively, verbs that share the same syntactic behavior have the same semantic structure. In contrast, semantic content is the actual “meaning” component of the verb, or what distinguishes a verb from other verbs sharing the same syntactic behavior. A simple example illustrates this distinction. Consider the verbs *run* and *jog*: their semantic structures are identical, i.e., they are both prototypical intransitive (unergative) verbs of motion. The

⁷i.e., the state of being broken

semantic content of *run*, however, differs from that of *jog* because it denotes a different manner of motion. This distinction has also been noted by other linguists; for example, Rappaport Hovav and Levin (1998), whose terminology I will adopt, draws the distinction between the *structural* and *idiosyncratic* components of verb meaning, which roughly corresponds to Grimshaw’s notion of semantic structure and semantic content. For Rappaport Hovav and Levin, the structural component of verb meaning is captured by event templates, while constants inserted into the event templates contribute the idiosyncratic component of meaning. Work in lexical semantics from other linguistic traditions also reflects this dichotomy; Construction Grammar, for example, distinguishes the facet of meaning inherent in a particular construction from the facet of meaning directly encoded by a verb (Goldberg, 1995, 2001; Goldberg and Jackendoff, 2003). In the Distributed Morphology framework, the verbalizing heads supply the “syntactic scaffolding” that licenses particular events (corresponding to the structural component of meaning). Verbal roots modify the basic event types and introduce the idiosyncratic meaning component.

With respect to the second issue (52b), I will argue that my particular inventory of verbalizing heads and verbal roots captures many generalizations about patterns of argument realization cross-linguistically. Furthermore, there is significant precedent in the literature on lexical semantics for the primitives that I am positing: v_{DO} is similar to Dowty’s DO and Rappaport Hovav and Levin’s ACT; v_{δ} is similar to BECOME, which is used by Dowty, Rappaport Hovav and Levin, and Parsons (and also Carter’s CHANGE); v_{BE} corresponds to Carter’s BE, and is implicit in both Dowty’s and Rappaport Hovav and Levin’s representations. Drawing evidence from Mandarin Chinese and English, the rest of this work will attempt to show that my framework can nicely account for a wide variety of interesting verbal phenomena.

1.2.1 Basic Event Structures

As previously discussed, each verbalizing head is, by hypothesis, a real syntactic element that enters the derivation process as a functional element—they license events and arguments within their verbal projections.

The verbalizing head v_{DO} licenses activities and is compatible with verbal roots that represent activity. Note that the relationship between v_{DO} and the verbal root is not head-complement, but rather head adjunction (the root is an event modifier):

(53) John ran.

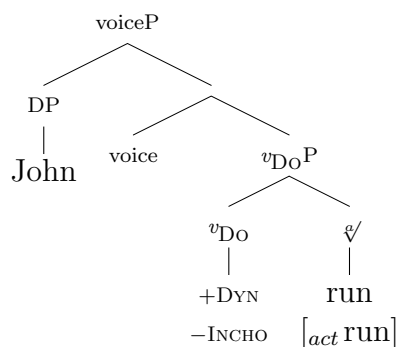

I assume that the entire *voice* phrase is further embedded under a tense projection (with the possibility of intervening aspectual projections), which I have omitted here for brevity. My theory adopts a version of the VP-internal subject hypothesis (Kitagawa, 1986; Kuroda, 1988; Koopman and Sportiche, 1991), whereby the external argument licensed by *voice* raises up to [Spec, TP] (accounting for typical stranding and reconstruction phenomena); this assumption, however, is not critical. Since my theory of verbal argument structure primarily concerns the composition of events, I will leave out all structure above *voice* in subsequent trees.

Intuitively, the meaning of sentence (53) can be paraphrased as “there is an activity of running, of which John is the agent”. More formally, the logical form of the above sentence would be (abstracting away from tense and aspect):

$$(54) \exists e[\text{ARG}_{ext}(\text{John})(e) \wedge \text{DO}([\textit{activity run}])(e)]$$

This representation is similar to Parsons’ in that both make explicit reference to underlying event variables. Instead of introducing arguments via thematic roles, however, I employ a generic label ARG_{ext} to indicate the external argument (introduced by *voice*), and the labels ARG_{do} , ARG_{δ} , and ARG_{be} to unambiguously refer to the structural arguments associated with v_{DO} , v_{δ} , and v_{BE} , respectively. A key claim of my work is that thematic roles can be reduced to canonical interpretations assigned to structural configurations.

Chomsky (1981) and Marantz (1984) were among the first to suggest that the external argument of a verb is not directly licensed by the verb itself. They argue that the external argument is actually an argument of the entire verbal predicate, not solely an argument of the verb. In Davidsonian terms, the external argument is related to the verb phrase via the event variable only. Recently, this has been developed into the theory of *voice* (Kratzer, 1994), a functional element that relates an external argument (its specifier) to an eventuality (its complement). This structural configuration allows the *voice* head to assign a particular semantic role to the external argument: agent, instrument, cause, and a few more. Note that Kratzer’s *voiceP* (1994) captures the same essential insights as Harley’s *CauseP* (1995; 1996), Travis’ *EventP* (1994), and Nishiyama’s *TrP* (1998).

In some cases, an activity verbal root can itself idiosyncratically license a DP to give rise to a transitive sentence:

(55) John ran the marathon.

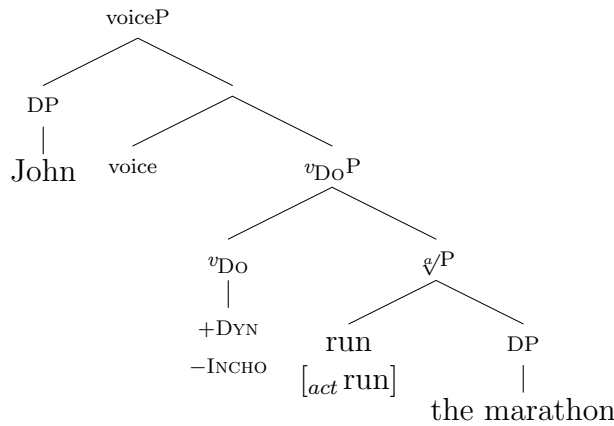

This structure can be paraphrased as “there is an activity of running the marathon, of which John is the agent”, with the following logical form:

(56) $\exists e[\text{ARG}_{ext}(\text{John})(e) \wedge \text{DO}([\textit{activity run}(\text{the marathon})])(e)]$

Obviously, the licensing of the DP by the verbal root is subjected to constraints imposed by semantic selection—this, for example, rules out the possibility of “*run the wall”. Note also that this argument is licensed purely by the specific semantics of the verbal root, i.e., there is nothing inherent about activities (that is, the structural component of meaning) that requires an argument of this type. Levin makes a similar distinction: some arguments are directly licensed by the event template (e.g., the theme/patient in externally-caused change of state verbs), whereas others are licensed by the constant (e.g., the object in verbs of manner of surface contact such as *wipe*). Verbs that idiosyncratically license their direct objects belong to a class she calls non-core transitive verbs (Levin, 1999).

Are all direct objects of activities introduced idiosyncratically by their roots? In other words, can *vDo* structurally license an argument in its specifier position? If so, what would be the interpretation of such an argument? According to Levin (1999), only causative change of state verbs such as *cut*, *destroy*, *kill*, transitive *break*, and transitive *open* qualify as core transitive verbs. She argues that these verbs fit the semantic profile of “agent acts on and causes an effect on patient”, and are “highly transitive”, in the sense of Hopper and Thompson (1980). Levin claims that verbs such as *kick*, *pound*, *rub*, and *sweep* are non-core transitive verbs because their objects lack a unified and independent semantic characterization.

I disagree with this position. While it is true that an activity such as sweeping does not necessarily bring about a change of state, i.e., one can sweep the floor without rendering it any cleaner, there is a reading of *sweep the floor* that fits the prototypical semantic profile of “agent acts on and causes an effect on patient”. These two readings arise from a syntactic ambiguity:

(57) John swept the floor.

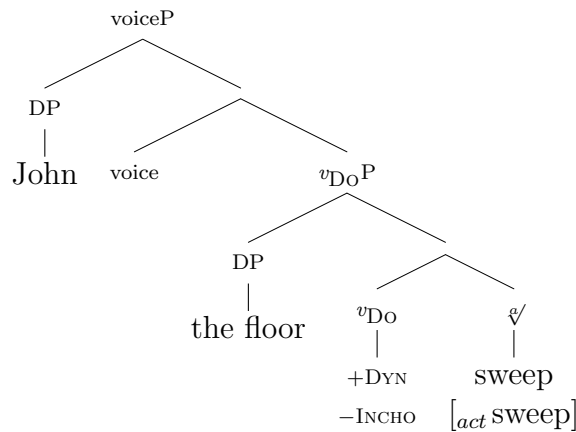
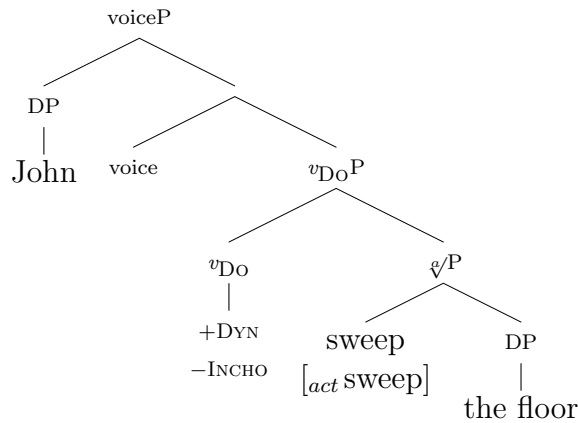

The structure on the top in (57) exactly parallels the structure shown in (55), and can be paraphrased as “there is an activity of sweeping the floor, of which John is the agent”. In this case, the floor is not an affected argument; in other words, John is interpreted as engaging in the activity of “floor-sweeping”. In contrast, the floor is an affected argument in the structure shown on the bottom of (57). This structure can be paraphrased as “there is an activity of sweeping that acts on and causes an effect on the floor, of which John is the agent.” A DP in the specifier of v_{Do} is interpreted as the affected argument of the activity; naturally, the detailed nature of the effect is determined by the semantics of the verbal root.

In short, a sentence such as “John swept the floor” is ambiguous between a pure activity reading and a reading that involves an activity acting on an affected argument. The logical forms of these two interpretations are given below:

- (58) a. $\exists e[\text{ARG}_{ext}(\text{John})(e) \wedge \text{DO}([\text{activity sweep}(\text{the floor})])(e)]$ (pure activity)
 b. $\exists e[\text{ARG}_{ext}(\text{John})(e) \wedge \text{ARG}_{do}(\text{the floor})(e) \wedge \text{DO}([\text{activity sweep}])](e)]$
 (activity with affected argument)

In the presence of different contexts, one reading can be rendered more salient than another. Take the following examples with the verb *wipe*:

- (59) a. After dinner every day, John wipes the table. (affected reading more salient)

- b. John wiped the table for hours yesterday, but just couldn't get the grime off. (pure activity reading)

The verbalizing head v_{BE} licenses static situations and is compatible only with verbal roots denoting states. The specifier of v_{BE} is the entity whose state is being described:

- (60) Mary is tall.

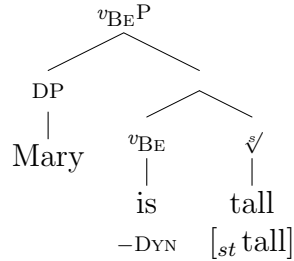

The above structure can be paraphrased as “there is state of Mary being tall”, with the logical form:⁸

- (61) $\exists s[\text{BE}([_{state} \text{tall}])(s) \wedge \text{ARG}_{be}(\text{Mary})(s)]$

A state can be embedded under a v_{δ} to give rise to an inchoative event (once again, the entire $v_{\delta}P$ is assumed to be embedded under a TP):

- (62) The window broke:

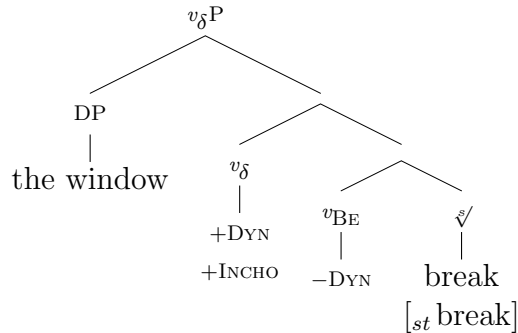

The specifier of v_{δ} is the entity that undergoes a change to the state specified by the verbal root associated with the inner v_{BE} ; this argument position is interpreted as the theme or patient of the verb. Intuitively, the above structure can be understood as “there is an inchoative event ending in the state of being broken, where the window is the entity undergoing the change of state.” The logical form would be something along the lines of:

- (63) $\exists e \exists s[\text{BE}([_{state} \text{break}])(s) \wedge \text{BECOME}(s)(e) \wedge \text{ARG}_{\delta}(\text{the window})(e)]$

⁸Parsons (1990:186-206) presents evidence that states (and maybe even nouns) refer to underlying state variables. See (Katz, 2000) for arguments against states having state variables. This point is not critical for my work.

Other unaccusative verbs in English share the analysis of *break* presented above. A verbal projection headed by v_δ can be optionally embedded as the complement of a v_{Do} , giving rise to the causative form of the sentence:

(64) John broke the window.

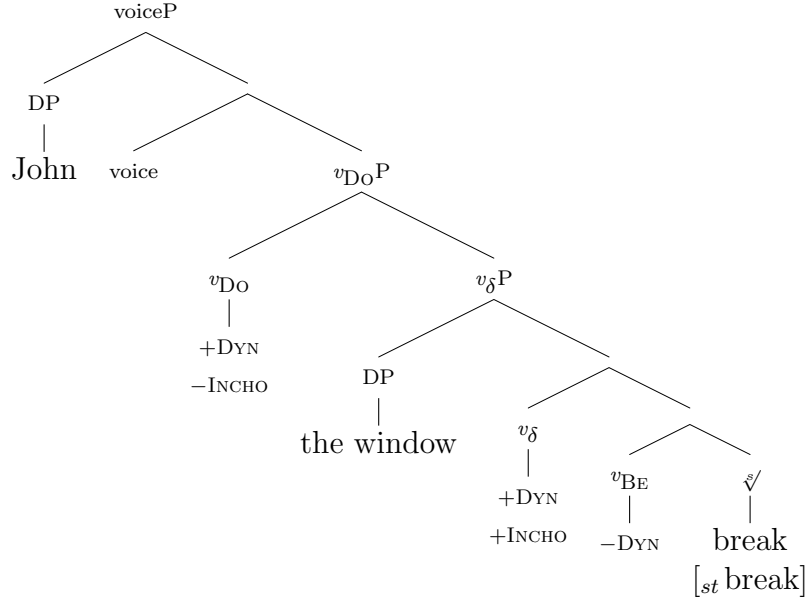

It is this presence or absence of the outer v_{Do} projection that accounts for the causative/inchoative alternation exhibited by many unaccusative verbs. Intuitively, the full structure may be understood as “there is an unspecified activity of which John is the agent, and there is an inchoative event ending in the state of being broken, of which the window is the entity undergoing the change of state, and the first event causes the second event”. In the more succinct language of symbolic logic:

(65) $\exists e_1[\text{ARG}_{ext}(\text{John})(e_1) \wedge \text{DO}([\text{activity } \text{undef}])(e_1) \wedge$
 $\exists e_2 \exists s[\text{BE}([\text{state } \text{break}])(s) \wedge \text{BECOME}(s)(e_2) \wedge \text{ARG}_\delta(\text{the window})(e_2) \wedge$
 $\text{CAUSE}(e_1)(e_2)]]$

My theory agrees with Dowty in analyzing causative sentences as bi-eventive, i.e., as being comprised of an inner inchoative core and an outer activity shell connected by an implicit causal relation (more on this later). Contra Levin and Rappaport Hovav (1995), I argue that the causative alternant of change of state verbs is derived from the more basic inchoative alternant (this issue will be taken up in Section 3.9).

As an interesting aside, it is a well known fact that other languages exhibit causativization patterns unavailable in English (examples from Pylkkänen, 2002):

(66) English:

- a. *John cried the baby.
- b. *John learned Mary Finnish.

(67) Japanese:

- a. *John-ga kodomo-o nak-asi-ta*
John-NOM child-ACC cry-CAUSE-PAST
'John made the child cry.'
- b. *John-ga Taroo-ni Eigo-o os-hie-ta*
John-NOM Taro-DAT English-ACC learn-CAUSE-PAST
'John taught Taro English.' (literally, 'John made Taro learn English')

(68) Finnish:

- a. *Jussi itke-tt-i last-ta*
Jussi cry-CAUSE-PAST child-PART
'Jussi made the child cry.'
- b. *Taro ope-tt-i Jussi-lle japani-a*
John-NOM learn-CAUSE-PAST Jussi-ABL Japanese-PART
'Taro taught Jussi Japanese.' (literally, 'Taro made Jussi learn Japanese')

Pykkänen (2002) explains this variation by a feature she calls “voice bundling”. In languages such as English, for example, the features of *voice* and v_{Do} (what she calls CAUSE) are “bundled” together into a complex head—the inability for another argument to intervene between the two heads blocks causativization of the form given above. In Japanese and Finnish, *voice* is disjoint from v_{Do} , which allows more flexibility in the realization of causatives.

The syntactic framework presented here captures a well-known asymmetry in the types of semantic roles that subjects and objects can take. Roles in the subject position of a sentence are typically limited to agent, cause, instrument, and a few more roles. The inventory of possible roles in the object position, however, is far more diverse. Levin (1999) provides the following examples:

- (69) a. The engineer cracked the bridge (patient)
b. The engineer destroyed the bridge (patient/consumed object)
c. The engineer painted the bridge (incremental theme)
d. The engineer moved the bridge (theme)
e. The engineer built the bridge (effected object/factitive)
f. The engineer washed the bridge (location/surface)
g. The engineer hit the bridge (location)
h. The engineer crossed the bridge (path)
i. The engineer reached the bridge (goal)
j. The engineer left the bridge (source)
k. The engineer saw the bridge (stimulus/object of perception)

1. The engineer hated the bridge (stimulus/target or object of emotion)

The source of this asymmetry stems from the difference in which subjects and objects are licensed (cf. Rappaport Hovav and Levin, 2003). Subjects are structural participants licensed either by *voice*, in the case of activities, or v_δ , in the case of unaccusatives. Thus, the semantics of the functional heads determines the roles of the subject. By comparison, objects can be licensed in three different ways: structurally by v_δ , in the case of causative change of state verbs, structurally by v_{Do} , in the case of activities with affected arguments, or idiosyncratically by an activity root, in the case of pure activities.

Pertaining to the licensing of direct objects, verbs can therefore fall into three different classes. With causative change of state verbs (i.e., the transitive form of *open* or *break*) the direct object must be structurally licensed by v_δ . With activity verbs such as *sweep* or *wipe*, there is an ambiguity between a pure activity reading and an activity with an affected argument reading. The former corresponds to an idiosyncratically licensed object, while the latter corresponds to an object licensed by v_{Do} . Finally, with unergative verbs such as *run* and *dance*, optional arguments are always idiosyncratically licensed by the verbal root itself. It is not possible to interpret “the marathon” and “the tango” in “run the marathon” and “dance the tango” as affected arguments. Since there are in principle no limits on the semantics of activity roots, the semantic relations between them and the event participants they license are not limited to a fixed inventory of roles. Thus, the subject/object asymmetry described above is directly reflected in the syntactic structure of sentences.

1.2.2 Causation and the Theory of Voice

An interesting aspect of my framework is its representation and encoding of causation. Whether causation is a relationship between two events (or more general, eventualities) or between an entity and an event is a much debated subject in both the philosophical and linguistic literature. It has also been suggested that cause is actually a three-place predicate involving a causer, a causee, and a patient (Alsina, 1992). Of particular linguistic relevance is the syntactic encoding of causation, i.e., is there an functional element *cause*, and a corresponding *causeP* projection? In this section, I will examine some of these issues in greater detail.

In my framework, cause is not directly represented in the syntax, but is rather an implicit relation between two eventualities, the most common of which is an activity causing a change of state, as in “John broke the vase”. In my framework, causation is a structural notion: the head-complement relation between a v_{Do} and the $v_\delta\text{P}$ that it selects. There appears to be no evidence for the existence of a *cause* head in the syntax that mediates a causer and a causee.

Ambiguity with adverbs such as *again* and *almost* have long been employed as a probe into the syntactic structure of sentences. Consider the repetitive/restitutive contrast in the following sentence:

(70) John closed the door again.

- i. John previously closed the door. He did it again. (repetitive reading)
- ii. Mary previously closed the door. John caused it to be in the same state again. (restitutive reading)

It is generally believed that the two different readings arise from a structural ambiguity,⁹ i.e., there are multiple “attachment points” for the adverb in the syntactic structure. If *again* is viewed as an operator, the different readings can be attributed to the scope of AGAIN: whether it is modifying the core change of state or the entire event:

(71) John closed the door again.

- i. AGAIN(John closed the door) = repetitive reading
- ii. John AGAIN(closed the door) = restitutive reading

See McCawley (1973) and Dowty (1979, chapter 5) for a more detailed treatment. The German counterpart of *again*, *wieder*, has been systemically investigated by von Stechow (1995; 1996; 1999), Klein (2001); also see references therein.

In English, a similar scope ambiguity arises with *almost*. Thus, it can serve as a probe into the nature of causation. If cause were syntactically encoded, i.e., as a *cause* functional head, the following three-way ambiguity would be predicted:

(72) John almost closed the door.

- i. *almost* applies to the causing event.
John almost got off his lazy ass to close the door.
- ii. **almost* applies to the cause.
John did something, which almost caused the door to close.
- iii. *almost* applies to the state/change of state.
The door was ajar, not fully closed.

The second reading is not available, which casts doubt on the existence of a *cause* head. If adverbial ambiguity is indeed a good test for the presence of syntactic elements, the syntactic framework I have presented should also predict a three-way ambiguity:

(73) John closed the door again.

- i. *again* applies to v_{DO} . (repetitive reading)
- ii. ?*again* applies to v_{δ} .
- iii. *again* applies to v_{BE} . (restitutive reading)

⁹as opposed to multiple distinct morphemes with the same phonological matrix

The situation in (73i) corresponds to the repetitive reading, i.e., repetition of the entire action, while the situation in (73iii) represents the restitutive reading, i.e., restoration of the state. The reading in (73ii) appears somewhat odd, but it has been attested in the literature. Von Stechow (1999) describes the following scenario:

- (74) The window opened by itself. Mary closed the window. John opened the window again.

Although the evidence is somewhat weak, reading (73ii) should not be ruled out as impossible. Then again, it is not entirely clear whether the restitutive reading is AGAIN(door be open) or AGAIN(door become open), and what the differences between those might be. The close association of v_δ and v_{BE} in comprising the core of a sentence might contribute to the inability to clearly untangle all these effects.

If causation is always a relation between two events (or eventualities), how are external arguments introduced? As mentioned previously, I adopt Kratzer’s (1994) theory of *voice*. Through a process called Event Identification, the functional head *voice* identifies a thematic relation between an entity and an event (s is the semantic type of eventualities):

- (75) Event Identification: $\langle e, \langle s, t \rangle \rangle \langle s, t \rangle \rightarrow \langle e, \langle s, t \rangle \rangle$

In the following (abridged) example, the external argument is introduced into a relation with the event denoted by v_{DoP} . In this case, the relationship is agent:

- (76) Mary danced.

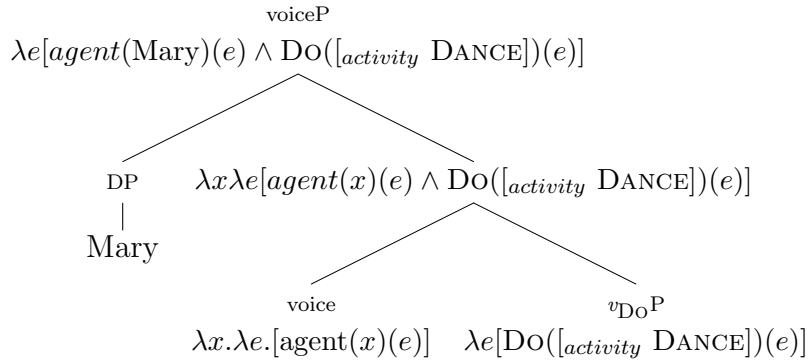

paraphrase: “There is an activity of dancing, of which Mary is the agent.”

The situation is similar for bi-eventive sentences such as “John broke the window”. The v_{Do} introduces a dynamic activity (that causes the change of state), while the *voice* head specifies the role of an external argument with respect to this activity; see (64).

Of course, agent is not the only possible role between an external argument and an event, although the inventory is quite limited (see earlier discussion about subject/object asymmetries). The following presents a short list:¹⁰

¹⁰Alternatively, it may be possible that the semantic relationship between *voice* and the external argument is simply a matter of construal.

- (77) Agent: $\lambda x.\lambda e.[\text{agent}(e, x)]$ (e.g., John opened the door)
the external argument is the agent of the causing event
- Instrument: $\lambda x.\lambda e.[\text{instrument}(e, x)]$ (e.g., The key opened the door.)
the external argument is the instrument of the causing event
- Identity: $\lambda x.\lambda e.[e = x]$ (e.g., The wind opened the door.)
the external argument *is* the causing event

In passing, the theory of *voice* also provides the potential basis for an explanation of the passive and middle constructions. In passives, the *voice* head is present, but it does not project an external argument (perhaps, the passive morphology somehow “absorbs” the external argument). Middles, however, do not involve *voice* heads at all. This hypothesized situation is shown in the following trees:

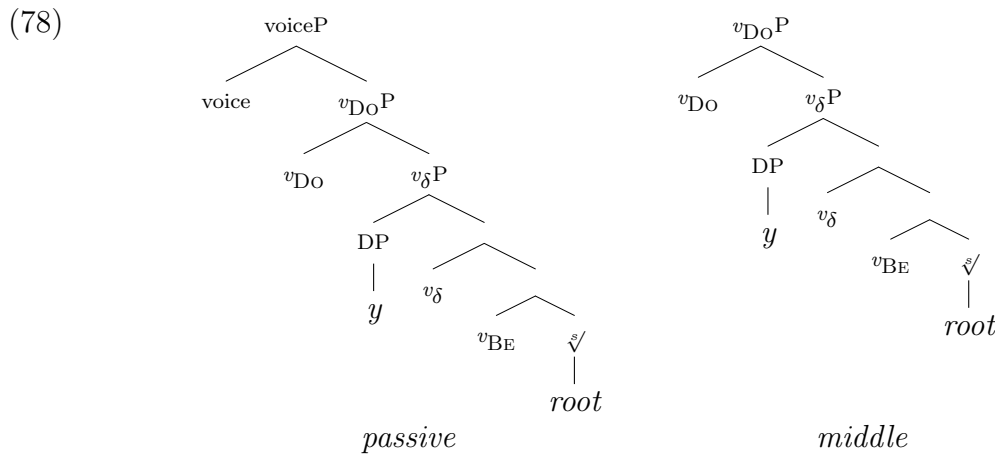

The above structures would account for well known differences with respect to control:

- (79) a. The ship was sunk to collect the insurance money.
b. *The ship sinks easily to collect the insurance money.
c. *The ship sank to collect the insurance money.

In (79a), the external argument has some implicit realization, which manifests in its ability to control the PRO subject of the infinitive, even without an explicit *by*-phrase (cf. Manzini, 1983). In Section 3.7, I will provide an analysis of the middle construction in the context of Mandarin resultative verb compounds. Clearly, a comprehensive theory of middles and passives is beyond the scope of this work, but I bring up this point to demonstrate the flexibility of my framework to potentially cover a broad range of verbal phenomena.

1.2.3 Underlying Syntactic Processes

To conclude the basic introduction to my framework of verb argument structure, I will discuss three key elements critical to the theory:

- (80) a. Compositional semantics.
 b. Some mechanism for semantic selection.
 c. Some syntactic process by which verbalizing heads acquire the phonological matrix of the verbal root.

Semantic compositionality refers to the notion, dating back to Frege, that the meaning of a linguistic expression is determined by the meanings of its parts. As it is one of the major tenets of formal linguistics, I will simply assume it without controversy. As a simple example of how logical forms can be compositionally derived from my proposed inventory of primitive elements, consider the following sentence:

- (81) The tire flattened.

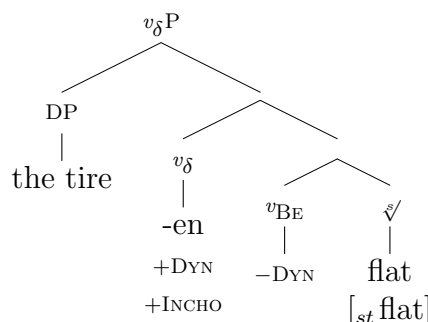

In later chapters, I will provide evidence that *-en* is indeed the inchoativizing functional head, i.e., v_δ . For now, given the above structure, the (informal) denotations of the relevant lexical items would be:

- (82) $\llbracket \sqrt{\textit{flat}} \rrbracket = [\textit{state flat}]$
 $\llbracket v_{\textit{BE}} \rrbracket = \lambda r \lambda s \textit{BE}(r)(s)$
 $\llbracket v_\delta \rrbracket = \lambda R \lambda n \lambda e \exists s [R(s) \wedge \textit{BECOME}(s)(e) \wedge \textit{ARG}_\delta(n)(e)]$

Putting the pieces together (assuming functional application at the branching nodes), we arrive at the denotation of the above sentence:

- (83) $\llbracket \textit{The tire flattened.} \rrbracket =$
 $\exists e \exists s [\textit{BE}([\textit{state flat}])(s) \wedge \textit{BECOME}(s)(e) \wedge \textit{ARG}_\delta(\textit{the tire})(e)]$

Note that we are abstracting away from tense and aspect; recall that $v_\delta P$ is further embedded under a tense projection, which would be responsible for existentially closing off the event variable underlying v_δ and establishing the relevant tense and aspectual relations.

An important aim of my work is to develop a syntactic theory that transparently supports interpretation at the syntax–semantics interface. As can be seen, each verbalizing head, verbal root, and structural argument has a well-defined position in the argument structure. For the rest of this work, however, I will omit denotations of various sentential elements in favor of a more intuitive explanation. I am confident,

however, that my syntactic structures can be formally interpreted in a manner similar to what I have sketched above.

Whereas compositionality drives structure building, semantic selection plays the counterbalancing role of constraining the range of possible structures: it partially governs the well-formedness of my event representation. Selectional restrictions between heads and roots, for example, ensure that a verbal root of a particular ontological type is properly paired with a corresponding verbalizing head—this is the notion of “semantic compatibility”, to borrow a term from Goldberg (1995:50). This type of selectional relation also corresponds to Rappaport Hovav and Levin’s canonical realization rules. Similar restrictions prevent non-sensical DPs from being licensed by verbal roots, for example, to ensure that the object of *run* is something “runnable” such as *marathon*, *lap*, *mile*, etc. Similarly, semantic selection restricts the object of a verb such as *wipe* to a surface (among other constraints). Note that my theory only depends on the existence of a plausible mechanism—the actual implementation of semantic selection is not critical. Within the Minimalist Program, however, feature checking is a plausible strategy for imposing selection restrictions. The “selector” feature on a head (Chomsky, 1995) governs whether or not two structures can enter into a MERGE relation (analogous to the probe in the AGREE relation)—although these selector features are typically assumed to be morphosyntactic in nature, they may nevertheless have a semantic component. Feature percolation from embedded heads can ensure that all checking of selectional criteria is performed locally. Alternatively, semantic features may be checked only at LF, such that all derivations corresponding to non-sensical events crash.

In order to correctly derive the surface word order from the analyses presented above, one must explain the process by which a higher functional element acquires the phonological content of embedded verbal roots. A plausible process for this is head movement (or *incorporation*), a well-studied and independently motivated syntactic phenomena (Baker, 1988). In the analysis of “John broke the window” in (64), the lower-most verbalizing head (v_{BE}) undergoes successive head movement, moving up to v_{δ} , v_{DO} , and *voice* (and even further up to Tense, where inflectional morphology is acquired). The verbal root, being a bound morpheme, is pied-piped along with the verbalizing head. The process is illustrated below:

(84) John broke the window.

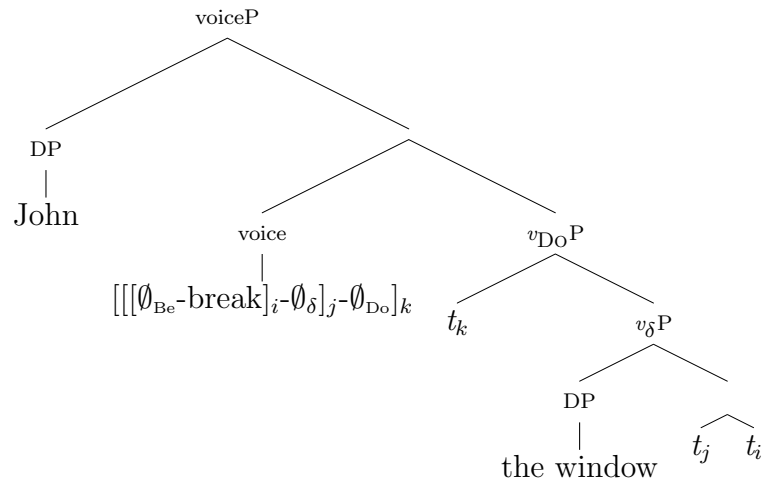

The derivation of the surface forms in my framework patterns with verbal incorporation commonly observed in many languages, which Baker (1988) explores in detail. Consider examples from Chichewa, a Bantu language:

- (85) a. *Mtsikana ana-chit-its-a kuti mtsuko u-gw-e.*
 girl AGR-do-make-ASP that waterpot AGR-fall-ASP
 ‘The girl made the waterpot fall.’
- b. *Mtsikana anau-gw-ets-a mtsuko*
 girl AGR-fall-made-ASP waterpot
 ‘The girl made the waterpot fall.’

The example in (85a) is bi-clausal, with an embedded clause appearing as an argument of the causative predicate in the main clause. In Chichewa, there is an alternate way of expressing the same meaning, via a single morphologically-complex verb, as in (85b). English displays a similar pattern with periphrastic causatives:

- (86) a. John made the window break.
 b. John broke the window.

Strictly speaking, the syntactic structures that I have been presenting do not correspond to a specific point in the derivation process—English strings are used as convenient shorthands for the bundle of features that they represent. Recall that phonological material is not inserted into the leaves of the syntactic structure until Spell-Out. Furthermore, for the sake of clarity, I will usually omit head movement and simply assume process along the lines of what I have described.

Head movement correctly derives the surface form of verbs in cases where the verbalizing heads are overt, as in *flatten*. Not surprisingly, this derivation obeys the Head Movement Constraint (Travis, 1984:131):

- (87) *The Head Movement Constraint (HMC)*
 An X^0 may only move into the Y^0 which properly governs it.

Note, however, that the notion of different levels of projection (e.g., X^0 vs. X') is not particularly meaningful within the Minimalist Program. Recent work attributes the HMC to a more general notion of minimality. What is important here is the observation that movement cannot skip over an intervening head.

Ultimately, one could appeal to the strength of the features on the verbalizing heads and “attraction” for deeper causes driving the movement. However, the actual details of the syntactic processes are not critical to my theory.

It is interesting to note, however, that Hale and Keyser collapse (80c), head movement, into (80b), semantic selection. They propose a process called conflation, which is a concomitant of MERGE:

- (88) Conflation consists in the process of copying the p-signature [phonetic features] of the complement into the p-signature of the head, where the latter is “defective”. (Hale and Keyser, 2002:63)

As defined by Hale and Keyser, conflation is not a movement process—it is label-copying process inseparable from MERGE. In other words, conflation is a relation between MERGE-partners, whereby the defective p-signature of a head is replaced by the p-signature of its complement. Hale and Keyser take this theory one step further: under the model of “Late Insertion” (Halle and Marantz, 1993), they consider the question of whether the copying of the p-signature is even necessary. There is nothing to prevent the phonological matrix of the item from being directly inserted into the verbal head. This, indeed, is the extension they pursue: Hale and Keyser boil conflation down to the ability of (phonologically overt) heads to license non-overt complements—which reduces to semantic selection. Although this theory integrates the different syntactic requirements critical to my framework for verbal argument structure, I need not adopt this particular analysis.

1.3 Key Claims

In this thesis, I will attempt to defend the following claims about natural languages in general:

Argument Structure to Event Structure Mapping

Argument structure can be reduced to event structure, a decompositional representation of events based on semantic primitives. The principles governing the realization of arguments can be wholly encapsulated in the event structure and the constraints acting thereon.

Event Structure to Syntactic Structure Mapping

Event structure is represented syntactically and compositionally constructed from a small inventory of functional elements and a large open-class collection of primitive concepts. The construction of “verb meaning” is governed by independently-motivated principles of syntax.

Components of Event Structure

Activity and state are the only two irreducible primitive concepts encoded by language. These conceptual roots, together with functional elements representing activity, stativity, and inchoativity, comprise the basic components of event structure.

Variations on Event Structure

Cross-linguistic differences in the realization and interpretation of verbal arguments can be reduced to parametric variations in the way functional elements interact with conceptual roots and other lexical categories. In addition, languages vary in the manner in which “meaning” is packaged into verbal roots.

1.4 Roadmap

The following serves as a rough guide to the rest of this thesis:

Chapter 2 provides basic support for my theory of verbal argument structure with evidence drawn primarily from Mandarin Chinese. A typological study of the Mandarin verbal system will reveal that verbs are either activity or stative verbs (with a few exceptions). For the most part, there are no simple monomorphemic accomplishments and achievements exist in Chinese—no simple verb necessarily encodes an end state, an end point, or implies the attainment of goal. Achievements appear to be syntactically derived from underlying stative roots, and accomplishments are further derived from achievements through verbal compounding. These facts provide the basic evidence that event composition is syntactic in nature.

Chapter 3 examines Mandarin resultative verb compounds (RVCs) in detail. Since resultative constructions involve complex composition of events, they serve as a good test for any theory of argument structure. I present a typological analysis of RVCs in Mandarin, highlighting the dimensions of variation that any theory must account for. I then show how my framework captures all the necessary requirements set forth, naturally accounting for semantic ambiguities and the ungrammaticality of certain forms. My syntactic analysis contributes to recent discussions in the literature regarding a Minimalist theory of control, since this syntactic device is employed to implement argument sharing in my framework. I demonstrate that the Minimum Distance Principle perspicuously captures the patterns of control exhibited in Mandarin, although there remain interesting open questions.

This chapter also rigorously defends my claim that the process of event composition is syntactic in nature; I compare my approach to an alternative “lexicalist” account where verbs directly introduce well-formed event structures into the syntax. Under this system, alternations in argument structure result from lexical rules. I will demonstrate that my syntactic framework better accounts for the empirical facts, particularly in Mandarin. Finally, I will compare my theory to other analyses of resultative verb compounds based on small clauses and articulated VP structures.

Chapter 4 focuses on cross-linguistic differences in the encoding of stative verbal roots in Mandarin and English. Whereas all Mandarin stative roots surface as stative verbs, some English stative roots appear as adjectives and others as inchoative verbs in their base form. I believe these differences can be attributed to parametric variations on the sensitivity of verbalizing heads to the property concept vs. result state distinction (Dixon, 1982).

Chapter 2

The Mandarin Verbal System

Having outlined my basic theory of verbal argument structure in the previous chapter, I will proceed to defend the claims set forth, primarily drawing evidence from Mandarin. Compared to English, the Chinese verbal system displays greater transparency in syntactically composing verb meanings from verbalizing heads and verbal roots. A detailed typological analysis of the Mandarin verbal system will reveal how event and argument structure is built up syntactically. A more detailed examination of cross-linguistic differences between Mandarin and English will be reserved for Chapter 4.

Before considering examples from Mandarin in greater detail, I would like to survey some *prima facie* evidence for my theory. Consider the following forms in O’odham, a Uto-Aztecan language of southern Arizona and northern Sonora, and Huallaga Quechua, a member of the Quechuan family spoken in Peru:

- (1) O’odham (Hale and Keyser, 1998:92)

<i>Adjective</i>	<i>Inchoative</i>	<i>Causative</i>	
(s-)weg-i	weg-i	weg-i-(ji)d	‘red’
(s-)moik	moik-a	moik-a-(ji)d	‘soft’
(s-)'oam	'oam-a	'oam-a-(ji)d	‘yellow’

- (2) Huallaga Quechua (Weber, 1989)

<i>Noun</i>	<i>Inchoative</i>	<i>Causative</i>	
qarwash-	qarwash-ta:-	qarwasy-ta:-chi-	‘yellow’
han	han	han	‘above on slope’
hatun	hatun-ya:-	hatun-ya:-chi	‘big’
umasapa-	umasapa-ya:-	umasapa-ya:-chi	‘big headed’

We can see clear evidence from the morphology in O’odham and Huallaga Quechua that inchoative verbs (*become X*) are derived from base stative forms (adjectives in O’odham, nouns in Huallaga Quechua¹) by the addition of a suffix. Causative change of state verbs (*cause to become X*) are further constructed from the inchoative forms

¹but see (Beck, 2002) for evidence that states are actually encoded as adjectives

with the addition of another suffix. This process appears to be productive, and suggests that the affixes in O’odham and Huallaga Quechua may be overt realizations of v_S and v_{Do} .

Consider, also, evidence from Warlpiri, a Pama-Nyungan language of Central Australia:

(3) Warlpiri (Hale and Keyser, 1998:93)

<i>Noun</i>	<i>Inchoative</i>	<i>Causative</i>	
wiri	wiri-jarri-	wiri-ma-	‘big’
maju	maju-jarri-	maju-ma-	‘bad’
rdilyki	rdilyki-ya	rdilyki-pi-	‘break’
larra	larra-ya	larra-pi-	‘crack’

All these unrelated languages exhibit similar patterns of morphological derivation. Unlike O’odham, where states are lexicalized as adjectives in their base form, Warlpiri patterns with Huallaga Quechua in encoding states as nouns. One possible interpretation of the morphological facts in Warlpiri is that the transitive (causative) morpheme *-ma-* supplants the intransitive (inchoative) morpheme *-jarri-*; this is consistent with the “Late Insertion” principle of Distributed Morphology (Halle and Marantz, 1993).

Even English, a language well-known for having impoverished morphology, shows evidence for deriving change of state verbs from underlying states:

(4) English

<i>Adjective</i>	<i>Inchoative</i>	<i>Causative</i>
red	redden	red
wide	widen	widen
dark	darken	darken
dim	dim	dim
clear	clear	clear
slow	slow	slow
modern	modernize	modernize

Suffixes such as *-en* and *-ize* in English derive change of state verbs from adjectives.² Interestingly, English also has zero-derived deadjectival verbs. From the surface form of these verbs, it is unclear whether the causative derives from the inchoative, or vice versa. Generalizing from Mandarin, I believe that verbal meaning is “built up”, in the sense that adding an inchoativizing element to states gives rise to a change of state, and further adding a causativizing element allows the introduction of an external argument. In Section 3.9, I argue against the paradigm of decausativization—deriving inchoatives from causatives by absorption of the external argument, an approach espoused by Levin and Rappaport Hovav (1995).

Finally, consider evidence from Tanoan, a major branch of the Aztec-Tanoan family of languages primarily found in New Mexico and Oklahoma:

²See (Jespersen, 1939) for phonological constraints on the *-en* suffix.

(5) Tanoan Unergatives (Hale and Keyser, 1998:115)

<i>Noun</i>		<i>Unergative</i>	
sae	‘work’	sae-’a	‘do work’
se	‘speech’	se-’a	‘do speech’
t,u	‘whistle’	t,u-’a	‘do whistle’
h,i,il	‘laugh’	h,i,il-’a	‘do laugh’
shil	‘cry’	shil-’a	‘do cry’
zaae	‘song’	zaae-’a	‘do song’

Once again, we see morphological evidence for the compositional construction of verb meanings from underlying semantic components. In this case, verbs denoting activities appear to be derived from underlying names of those activities.

2.1 Salient Features of Mandarin Chinese

Having briefly surveyed a few languages that appear to provide *prima facie* support for my theory, I will focus in detail on evidence from Mandarin Chinese. The organization of the Mandarin verbal system closely parallels my theoretical framework in an overt manner, making it an appropriate target of study. Recall my primary claims: argument structure can be reduced to event structure, which is itself syntactically encoded; events are constructed from an inventory of three verbalizing heads and two types of verbal roots. Certain features of the Chinese verbal system readily support these claims:

- (6)
 - a. For the most part, activity and state are the only two primitive verbal types in Mandarin Chinese. As a general rule, change of state predicates (accomplishments and achievements) are derived syntactically.
 - b. With very few exceptions, no monomorphemic verbs in Mandarin are telic—no monomorphemic verb encodes a result, a natural end point, an end state, or the attainment of a goal.
 - c. The particle *le* signals inchoativity.

The two primitive verbal types in Mandarin directly correspond to the two ontological types of verbal roots I have posited. I will provide two types of evidence for claim (6a): Unlike English, which has monomorphemic activity/achievement verb pairs, Mandarin achievements must be derived from activities through the formation of verbal compounds. Incremental theme verbs, which are typically considered accomplishments in English, denote activities in Mandarin that do not necessarily imply a natural end point. The claim (6b) is a corollary of (6a), since activities are by definition atelic. In support of claim (6c), I present a series of minimal pairs differing only in the presence or absence of the particle *le* that exhibit a state/change of state contrast, suggesting that the semantic component of inchoativity must be contributed by *le*.

In addition to the above claims, a few clarifications are necessary: Although the particle *le* signals inchoativity when placed immediately after a stative verb, it is *not* the overt realization of v_δ . Like many Chinese linguists, I consider verbal *le* to be a perfective marker. A discussion of this “perfective state” mystery will be taken up in Section 2.7. A related issue is the contribution of my work to the single *le* vs. multiple *les* debate in the literature on Chinese: my theory does not favor one view over another, but is compatible with both accounts. I identify a semantic component of *le* that has not previously been explicated in a clear manner. This, however, does not necessarily imply that there are multiple *les*—in principle, an appropriately underspecified *le* (interacting with different environments) could still give rise to all attested meanings. My work focuses primarily on verbal *le*, and my theory contributes little to the question of sentential *le* in Mandarin.

In the pages to come, I first review relevant prior work before endeavoring to defend my claims. As a brief preview, I will argue that the organization of the Mandarin verbal system can be schematically represented as follows:

- (7) **primitive event types:** activity, state
state + *le* → achievement
activity + achievement → accomplishment

In the following chapter, I will extend and refine my framework to analyze resultative verb compounds in Mandarin Chinese.

2.2 Previous Work

2.2.1 Deriving Accomplishments and Achievements

The somewhat controversial claim that no monomorphemic verbs in Mandarin encode accomplishments or achievements has been previously made by a number of linguists. Tai and Chou (1975), in their study of the verb *sha*₁ ‘kill’, claim that no Chinese action verb necessarily implies the attainment of a goal. Chu (1976) similarly argues that Chinese verbs are generally “non-implicative”, and that implications must be expressed by “separate syntactic devices”. Tai (1984) argues that activity, state, and result are the basic verbal categories in Chinese. He distinguishes results and states based on their compatibility with the intensifier *hen*₃ ‘very’:

- (8) a. *hen*₃ *gao*₁
very tall
‘very tall’
b. **hen*₃ *si*₃
very dead
intended: ‘very dead’

Tai argues that since *si*₃ ‘dead’ is not compatible with *hen*₃, it must be a result, distinguished from *gao*₁ ‘tall’, a state. However, this dichotomy is unmotivated: if

Chinese does indeed have state and result as two separate event types, it would be unique among languages. A much more plausible explanation is that *si*₃ ‘dead’ and *gao*₁ ‘tall’ are both states, but states differ in their compatibility with degree interpretations, i.e., height is a continuous (gradeable) measure, whereas dead/not dead is a binary distinction.

Shi (1988), also working in Chinese, extends Tai’s generalization and argues that in general, languages have only two primitive verbal categories, state and activity. Accomplishments and achievements are complex categories:

- (9) Achievements are basically states, but they differ from states in that they describe new states, i.e., change of state. Accomplishments are basically activities, but they differ from activities in that they encode causative activities. (Shi, 1988:59)

Other linguists have noted that accomplishments combine semantic elements of both activities and change of states. Accomplishment verbs primarily denote an activity, but also encode an end state. It is therefore conceivable that these two semantic components are encoded separately. Linguists have also noted that achievements differ from accomplishments only in the duration of the relevant event (Tenny, 1987:20); Pustejovsky (1991) groups achievements and accomplishments into the category he calls transition. Therefore, claiming that change of states are derived from underlying states does not seem particularly far-fetched.

Although the lack of monomorphemic accomplishments and achievements in Mandarin has been previously suggested, supporting arguments have not been thorough in examining the range of empirical facts. Previous works do not in fact *prove* this claim. The data presented by Tai and others merely demonstrates that many events which appear to be accomplishments or achievements at first glance, are, upon closer examination, actually verbal compounds or unbounded activities that do not encode explicit end points or end states. In fact, no one has systematically studied a broader range of Chinese verbs to verify these claims. Asserting the non-existence of certain verb types is a strong statement that can be invalidated by a simple counterexample. Thus, unless one considers *all* verbs in Mandarin, this claim cannot be truly substantiated. Although a detailed examination of every single verb in Mandarin is clearly beyond the scope of this work, I will attempt to better defend the claims set forth in (6) by both closely reexamining previous evidence and considering a much wider range of empirical data.

2.2.2 The Particle *le*

The proper analysis of the particle *le* in Mandarin is the subject of intense debate among scholars. The particle can appear in two different positions: directly following the verb (or verbal compound) or at the end of a sentence; these instances are referred to as verbal *le* and sentential *le*, respectively.³ However, both the verbal *le* and sentential *le* can co-occur in a single sentence, giving rise to so-called double *le* sentences.

³Both *les* are orthographically identical, although phonetically different in certain Mandarin dialects.

Even after decades of debate, there is still little consensus as to whether the verbal *le* and sentential *le* are in fact the same morpheme. For example, Rohsenow (1977), P. Li (1989), and Shi (1988), among others, argue that there is only one *le*, whose interpretation varies in different syntactic environments. Not surprisingly, these linguists concentrate on the similarities of the different semantic roles that *le* plays in its many uses. On the other hand, Chao (1968), Li and Thompson (1981), and Sybesma (1999), just to cite a few authors, argue that verbal *le* and sentential *le* are distinct morphemes with different meanings.

Despite disagreements regarding the proper treatment of verbal and sentential *le*, proponents of both approaches generally agree that the semantic function of sentential *le* is a marker of inchoativity.⁴ For example, Chao (1968:798-800) lists seven uses of sentential *le*:

- (10) a. Inchoative *le*
- b. Command in response to a new situation
- c. Progress in story
- d. Isolated event in the past
- e. Completed action as of the present
- f. Consequent clause to indicate situation
- g. Obviousness

Along the same lines, says Chang (1986) of sentential *le*:

- (11) a. It serves to express a “change of state” meaning.
- b. It serves as a discourse-final particle, marking the end of a discourse unit
(Chang, 1986:120,122)

Li and Thompson (1981:240) specifically use the term “Currently Relevant State” (CRS) to describe the meaning conveyed by sentential *le*. The notion of Current Relevant State essentially sets up an opposition between the state preceding the sentence and the present moment, implying some sort of change or transition. More specifically:

- (12) The sentential *le* conveys CRS if the state of affairs it represents
 - a. is a changed state,
 - b. corrects a wrong assumption,
 - c. reports progress so far,
 - d. determines what will happen next, or
 - e. is the speaker’s total contribution to the conversation at that point.

⁴Among scholars who argue for a two-morpheme treatment of *le*, there is little agreement on whether or not sentential *le* is an aspectual marker.

(Li and Thompson, 1981:244)

A few examples illustrate the use of sentential *le*:

- (13) a. *wo*₃ *ting*₁ *dao*₄ *xin*₁*wen*₂ *le*₅
I listen arrive news LE
'I heard the news.'
- b. *ta*₁ *you*₃ *yi*₁ *ge*₅ *hai*₂*zi*₅ *le*₅
ta has one CL child LE
'He has a child now.'
- c. *ta*₁*men*₅ *chi*₁ *wan*₂ *fan*₄ *le*₅
they eat finish meal LE
'They have finished eating.'

All of the above sentences describe a state of affairs that holds now, implying that it did not before. In (13a), for example, a contrast is set up between a state where the speaker did not know the news and the current state of the speaker knowing the news. The implication of (13b) is that he did not have a child before, as he does now. The example in (13c) denotes the coming about of a state in which they have finished eating.

Verbal *le* in Mandarin is typically taken to be an aspectual marker related to perfectivity, boundedness, and completion (Wang, 1965; Chao, 1968; Li and Thompson, 1981). For an alternative view, see Shi's (1990) analysis of both verbal and sentential *le* as a marker of relative anteriority, and J.-W. Lin's (2003) treatment of verbal *le* as an event realization marker based on Bohnemeyer and Swift's (2001) concept of "event realization".

In this work, I will make the more traditional assumption that verbal *le* marks perfectivity. Comrie's (1976) seminal work on aspect serves as a starting point for many discussions; the following is his definition of the perfective aspect:

- (14) perfectivity indicates the view of a situation as a single whole, without distinction of the various separate phases that make up that situation.
(Comrie, 1976:16)

Unfortunately, this definition does little to clarify the notion of perfectivity, and has indeed been the focus of much subsequent debate. What exactly does it mean to "view" a situation "as a whole"?

To Chao (1968), verbal *le* is a marker of completion. Li and Thompson (1981), however, equate perfectivity with boundedness. They suggest that a situation is "viewed as a single whole" if it is bounded, and that a situation is bounded if "temporal, spatial, or conceptual limits are placed on it" (p. 186). More specifically, they propose the following criteria:

- (15) A situation is considered bounded:
- a. if it is quantified,
 - b. if it is definite or specific,
 - c. if the verb is inherently bounded, or
 - d. if it is the first event in a sequence.

As pointed out by Shi (1990), this account is problematic. According to Li and Thompson, boundedness (and perfectivity, indirectly) is determined by various semantic and syntactic criteria, which in turn license the verbal *le*. This implies that verbal *le* is independent of aspect—because perfectivity licenses verbal *le*, not the other way around. Thus, verbal *le* is reduced to a redundant co-occurrence of the perfective aspect, and hence should have no impact on the grammaticality or interpretation of a sentence. This prediction is clearly wrong: the presence or absence of verbal *le* obviously contributes to the aspectual and semantic interpretation of Mandarin sentences.

A deeper problem with Li and Thompson’s analysis, I believe, stems from a confusion of what is meant by aspect. Smith (1991), among others, convincingly argues that what linguists commonly refer to as “aspect” is in fact two separate and independent types of properties, which she terms *situational aspect* and *viewpoint aspect*. Situational aspect refers to Vendler’s classification of event types, often known as lexical aspect or *aktionsart*.

Viewpoint aspect, on the other hand, refers to the encoding of a particular situation on a particular occasion with reference to a temporal interval: in the words of Smith (1991:172), “the viewpoint focuses on the situation as it unfolds in time”. Abstractly, events can be viewed as potentially having an initial point, an end point, and internal stages. *Imperfective* viewpoint aspect can be thought of as focusing on only the internal stages of an event, without specific regard for either the initial or the end point. *Perfective* viewpoint aspect,⁵ on the other hand, focuses on an event as a whole, without regard to its internal stages. Therefore, the perfective aspect crucially includes both the initial and end points of an event—hence its relationship to boundedness. It is to be emphasized that situational aspect and viewpoint aspect are independent and orthogonal properties, as demonstrated by the following English sentences:

- (16) a. Mary sang. (activity, perfective)
b. Mary is singing. (activity, imperfective)
- (17) a. John wrote a poem. (accomplishment, perfective)
b. John is writing a poem. (accomplishment, imperfective)

⁵Since the imperfective and perfective are unambiguously viewpoint aspects, I will henceforth omit “viewpoint” for brevity.

The above examples present an activity and an accomplishment in either perfective or imperfective aspect. For an event such as singing, which is inherently an atelic activity, the perfective aspect introduces an arbitrary end point. In English, the *be ... -ing* verb form marks the imperfective aspect, whereas the perfective aspect does not appear to have any overt morphological expression. Instead, it is believed that a past tense verb comes to be interpreted as perfective when it is not otherwise marked for the imperfective aspect.

Given this clarification of aspectual properties, it appears that Li and Thompson conflate the independent properties of situational and viewpoint aspect in their analysis of the Mandarin verbal *le*. Boundedness is a situational notion, whereas perfectivity is a viewpoint notion.

How then, should viewpoint aspect be treated? I adopt the work of Klein (1994), who reduces tense and aspect to logical relations between intervals of time. Viewpoint aspect, according to him, is a relation between the interval of time during which an event takes place (called situation time, abbreviated TSit) and the time interval about which a sentence makes an assertion (called topic time, abbreviated TT). Tense, on the other hand, is a relation between the topic time and the time the sentence is uttered (time of utterance, abbreviated TU). Given these intervals, the imperfective aspect can be defined as the situation where TT is properly contained in TSit, and perfective aspect describes the situation where TSit is contained (properly or improperly) in TT.

While I disagree with Li and Thompson's specific analysis of verbal *le*, I do share, like many other Chinese linguists, the intuition that it functions as a perfective marker. Accordingly, I will adopt Klein's definition of perfectivity. Consider the following examples of verbal *le*:

- (18) a. *ta₁ zou₂tian₁ ku₁ le₅ yi₁ ge₅ zhong₁hou₂*
 he yesterday cry LE one CL hour
 'He cried for an hour yesterday.'
- b. *ta₁ zou₂tian₁ kan₃ dao₃ le₅ yi₁ ke₁ shu₄*
 ta yesterday chop fall CL one CL tree
 'He chopped down a tree yesterday.'

In both examples, the situation time (crying and chopping down the tree) is contained within the topic time (yesterday). The logical relationship between topic time and situation time allows a listener to automatically draw the inference that the relevant event has been completed (and hence bounded). Klein's definition of perfectivity, therefore, subsumes previous treatments of verbal *le* that depend on notions of boundedness and completion. In most Mandarin sentences, however, topic time is not explicitly mentioned and must be contextually determined.

This, however, cannot be the complete story. Treating verbal *le* as a containment relationship between topic time and situation time makes incorrect predictions with respect to stative verbs (see Section 2.7). States represent inherently unbounded, non-dynamic situations, and it is unclear what viewing states perfectly would

entail. Most linguists, therefore, dismiss verbal *le* occurring with stative verbs as ungrammatical. Some purported evidence for this claim is shown below:

- (19) a. **wo₃ xi₃huan₁ le₅ mu₄gua₁*
 I like LE papaya
 intended: ‘I liked papaya.’ (Li and Thompson, 1981:202)
- b. **ta₁ xiang₄ le₅ ba₄ba₅*
 he resemble LE dad
 intended: ‘He resembled dad.’ (Ross, 1995:110)
- c. **ta₁ cong₁ming₂ le₅ (yi₁ dian₃)*
 he intelligent LE a little
 intended: ‘He became intelligent (a bit smarter).’ (Rohsenow, 1977:277)
- d. **ta₁ zhi₁dao₄ le₅ nei₄ jian₄ shi₄*
 he know LE that CL matter
 intended: ‘He learned about that matter.’ (Sybesma, 1997:223)

However, this claim is simply not true—the conclusions drawn by other linguists appear to have been made without considering a broader range of empirical facts from Mandarin. Even in the literature, grammaticality judgments on verbal *le* with statives vary; J.-W. Lin (2003:268), for example, marks a sentence like (19d) grammatical. Turing to the World Wide Web, it is not very difficult to find instances of all of the above stative predicates co-occurring with verbal *le*:

- (20) a. *dang₁ ta₁ fang₄qi₄ de₅ shi₂hou₄, ni₃ que₄ fa₁xian₄ zi₄ji₃*
 when he give.up DE time, you but discover yourself
yi₃jing₁ xi₃huan₁ le₅ ta₁
 already like DE him
 ‘Only when he’s given up did you finally discover that you like him.’
 (from a widely circulated poem about cherishing the moment)
- b. *ching₁chen₂ geng₄ xiang₄ le₅ shi₁yi₄ hou₄ de₅ jing₃se₄*
 early-morning even resemble LE loss-memory after DE scenery
 literally: ‘The early mornings start to resemble the scenery after a memory loss.’
 (lyrics of a Mandarin pop song)
- c. *hou₄lai₂ ta₁ cong₁ming₂ le₅ yi₁ dian₃, kan₄ tou₄ le₅ wo₃*
 afterwards he intelligent LE a little see through LE I
de₅ xing₁
 DE heart
 ‘Afterwards, he became smarter and was able to see right through my heart.’
- d. *wo₃ zhi₁dao₄ le₅ she₂me₅ shi₄ xian₄dai₄hua₄*
 he know LE what is modernize
 ‘I now know what modernization truly is.’
 (quote attribute to Deng Xiaoping upon visiting a Japanese factory)

Interestingly, many authors who assert the ungrammaticality of sentences such as those in (19) have no problems with the following sentences:

- (21) a. *ta*₁ *gao*₁ *le*₅ *san*₁ *gong*₁*fen*₁
 I tall LE three centimeter
 ‘He grew three centimeters.’
- b. *wo*₃ *pang*₄ *le*₅ *liang*₃ *gong*₁*jin*₁
 I fat LE two kilogram
 ‘I gained two kilograms in weight.’ (literally: ‘I fattened two kilograms.’)

By most accounts, *gao*₁ ‘tall’ and *pang*₄ ‘fat’ are stative verbs.⁶ What, then, accounts for the felicity of such sentences? The proposal that I will explore in greater detail is that verbal *le* signals inchoativity.

2.3 Activities and States

Building on the work of Tai (1984), Shi (1988), and others, I will focus in this section on the claim that activity and state are the only two primitive verbal types in Mandarin Chinese. Change of state predicates, therefore, must be derived; furthermore, I will show that this process is syntactic in nature. With very few exceptions, there are no telic monomorphemic verbs in Mandarin—no monomorphemic verb encodes a result, a natural end point, an end state, or the attainment of a goal.

In this section, I will present two arguments supporting this claim: the first involves activity/achievement verb pairs in Mandarin, and the second concerns incremental theme verbs. In the next section, I will turn my attention to inchoativity in Mandarin.

2.3.1 Activity/Achievement Verb Pairs

A property of English is the existence of activity/achievement pairs—verbs with similar meaning, differing only in telicity and an end state:

- (22) *activity* *achievement*
 look (at) see
 listen (to) hear
 study learn
 look for find

In the above examples, it is evident that a verb such as *look (at)* denotes an unbounded activity, whereas its achievement counterpart, *see*, encodes a natural end point, i.e., the successful act of perception. Established diagnostics (Dowty, 1979) clearly distinguish the two sets of verbs presented above. Activities sound odd with *take a few minutes to V* and achievements sound odd with *spend a few minutes V-ing*:

⁶Sybesma (1997), however, argues that such verbs are activities.

- (23) a. John spent a few minutes looking at the picture/listening to the music/studying the Chinese characters/looking for his keys.
 b. ??It took Mary a few minutes to look at the picture/to listen to the music/to study the Chinese characters/to look for his keys.
- (24) a. ??Mary spent a few minutes seeing the picture/hearing the music/learning the Chinese characters/finding her keys.⁷
 b. It took Mary a few minutes to see the picture/to hear the music/to learn the Chinese characters/to find her keys.

In contrast to English, Mandarin has no corresponding activity/achievement verb pairs. To encode an end point, a speaker must resort to a verbal compound:

- (25) *activity* *achievement*
*kan*₄ ‘look’ *kan*₄ *jian*₄/*dao*₄ ‘look-perceive/arrive’ = see
*ting*₁ ‘listen’ *ting*₁ *jian*₄/*dao*₄ ‘listen-perceive/arrive’ = hear
*xue*₂ ‘study’ *xue*₂ *hui*₄ ‘study-able’ = learn
*zhao*₃ ‘look for’ *zhao*₃ *dao*₄ ‘look.for-arrive’ = find

In Chinese, no monomorphemic counterparts to English achievements exist; verbs such as *ting*₁ ‘listen’ and *zhao*₃ ‘look for’ express atelic activities. To encode the successful attainment of a goal (e.g., a result state or a successful act of perception), Mandarin speakers must employ verbal compounds, where the first verb typically denotes an activity, and the second verb a result state. As I will show in detail later, the second verb of these compounds are stative, not unaccusative. For verbs of perception, two different result morphemes are often used: *jian*₄, best glossed as ‘perceive’, and *dao*₄, literally ‘arrive’ (naturally, the result state is interpreted metaphorically). The claim that verbal compounds are required to explicitly encode the attainment of a goal is supported by the grammaticality of sentences that explicitly deny the end state:

- (26) a. *ta*₁ *kan*₄ *le*₅ *ban*₄ *tian*₁, *ke*₃*shi*₄ *mei*₂ *kan*₄ *jian*₄/*dao*₄
 he look LE half day but not-have look perceive/arrive
 ‘He looked for a long time, but couldn’t see it.’
- b. *ta*₁ *ting*₁ *le*₅ *ban*₄ *tian*₁, *ke*₃*shi*₄ *mei*₂ *ting*₁ *jian*₄/*dao*₄
 he listen LE half day but not-have listen perceive/arrive
 ‘He listened for a long time, but couldn’t hear it.’
- c. *ta*₁ *xue*₂ *le*₅ *ban*₄ *tian*₁, *ke*₃*shi*₄ *mei*₂ *xue*₂ *hui*₄
 he study LE half day but not-have study able
 ‘He studied for a long time, but wasn’t able to learn it.’

⁷The verb *learn* appears to be a so-called “degree achievement” that is compatible with both telic and atelic readings. Note, however, that “to spend a few minutes learning the Chinese characters” sounds odd in the context of having learned *all* the characters.

- d. ta_1 $zhao_3$ le_5 ban_4 $tian_1$, ke_3shi_4 mei_2 $zhao_3$ dao_4
 he look.for LE half day but not-have look.for arrive
 ‘He looked for a long time, but couldn’t find it.’

If the verbal compound is used in the first clause, however, then it becomes infelicitous to deny the end state. As an example:

- (27) $*ta_1$ $zhao_3$ dao_4 le_5 ban_4 $tian_1$, ke_3shi_4 mei_2 $zhao_3$ dao_4
 he look.for arrive LE half day but not-have look.for arrive
 intended: ‘He found it for a long time, but couldn’t find it.’

This evidence suggests that, at least for these classes of verbs, activities represent the base verbal form; achievements are derived by the process of verbal compounding. In later sections, it will become clear that this process of event composition is syntactic in nature.

2.3.2 Incremental Theme Verbs

The lack of monomorphemic incremental theme accomplishments has been previously used as support for the hypothesis that Mandarin verbs encode only activities and states (Tai, 1984).

The study of incremental themes figures prominently in theories of Tenny (1987; 1992; 1994). The central principle underlying her work is the Aspectual Interface Hypothesis (AIH):

- (28) *Aspectual Interface Hypothesis*

The mapping between thematic structure and syntactic argument structure is governed by aspectual properties. A universal aspectual structure associated with internal (direct), external, and oblique arguments in syntactic structure constrain the kinds of event participants that can occupy these positions. Only the aspectual part of thematic structure is visible to the syntax.
 (Tenny, 1992:2)

The crucial constraint on the realization of arguments can be stated as follows:

- (29) The internal argument of a simple verb is constrained so that it either undergoes no change or motion, or it undergoes change or motion which “measures out the event” over time. (Tenny, 1992:3)

Tenny uses the measuring-out property in an informal sense, as a convenient metaphor for uniform and consistent change. The following examples better illustrate the concept:

- (30) a. perform a play
 b. translate a poem

The internal arguments of (30a) and (30b) provide the temporal bounds for the events they describe. The performance of a play begins with the first act, then the second act, and so forth. The translation of a poem begins with the first stanza, then the second stanza, and so forth. As a result, the play and the poem measure out their respective events. This characterization is shared by Dowty (1991), who terms the direct objects in (30) *incremental themes*, one of his proto-patient entailments.

By most accounts, events in English such as *write a letter* and *paint a picture* (which involve incremental theme verbs) are considered accomplishments.

- (31) a. John wrote a letter yesterday.
 b. John painted a picture yesterday.

Since the sentences in (31) are accomplishments, and hence telic, the event is interpreted to have reached its natural end, i.e., the letter is finished and the picture is completed as a result of their respective actions. That is, incremental theme verbs encode a particular end state of their internal arguments. Thus, denying the completion of the objects would result in a contradiction:

- (32) a. #John wrote a letter yesterday, but he didn't finish it.
 b. #John painted a picture yesterday, but he didn't finish it.

However, this is not the case in Chinese. The counterparts of the sentences in (32) are perfectly acceptable in Mandarin:

- (33) a. *wo₃ zou₂tian₁ xie₃ le₅ yi₁ feng₁ xin₄, ke₃shi₄ mei₂ xie₃*
 I yesterday write LE one CL letter but not-have write
wan₂
 finish
 'I wrote a letter yesterday, but I didn't finish it.'
 b. *wo₃ zou₂tian₁ hua₄ le₅ yi₁ fu₂ hua₄, ke₃shi₄ mei₂ hua₄*
 I yesterday paint LE one CL picture but not-have paint
wan₂
 finish
 'I painted a picture yesterday, but I didn't finish it.'

Note that the above sentences are in the perfective aspect, yet no sense of completion is implied; that is, the event does not culminate in its natural end. The results of this “contradiction test” show that there are no simple accomplishments in Mandarin, only activities—unbounded events that do not specify a particular end point (in the perfective aspect, the event is interpreted as terminating at an arbitrary point). Paralleling verbs of perception in Mandarin, a verbal compound must be employed to ensure the completion of the theme, e.g., *xie₃ wan₄* ‘write finish’. I will demonstrate later that *wan₄* and other verbs in the second position are stative. With such compounds, the assertion that theme is not complete *does* result in a contradiction:

- (34) a. #wo₃ zou₂tian₁ xie₃ wan₂ le₅ yi₁ feng₁ xin₄, ke₃shi₄ mei₂
 I yesterday write finish LE one CL letter but not-have
 xie₃ wan₂
 write finish
 intended: ‘I finished writing a letter yesterday, but I didn’t finish it.’
- b. #wo₃ zou₂tian₁ hua₄ wan₂ le₅ yi₁ fu₂ hua₄, ke₃shi₄ mei₂
 I yesterday paint finish LE one CL picture but not-have
 hua₄ wan₂
 paint finish
 intended: ‘I finished painting a picture yesterday, but I didn’t finish it.’

The compatibility of incremental theme verbs with temporal adverbials presents additional evidence that they are activities in Mandarin. If such verbs are indeed atelic, then they should be grammatical with durative adverbials (e.g., *for an hour*, but not with frame adverbials (e.g., *in an hour*). For verbal compounds, the opposite situation should be true. In Mandarin, a bare temporal adverbial, e.g., *yi₁ ge₅ zhong₁tou₂* ‘one hour’, is interpreted in a durative manner. Verb reduplication is necessary, however, in many circumstances to render the sentence grammatical. The construction *zai₄ X nei₄*, literally ‘at X in’, is the Chinese equivalent of the frame adverbial. See (Liu, 1997) for discussions about these diagnostics. Having set up the predictions, we see that they are indeed borne out:

- (35) a. wo₃ xie₃ na₄ feng₁ xin₄ xie₃ le₅ yi₁ ge₅ zhong₁tou₂
 I write that CL letter write LE one CL hour
 (ke₃shi₄ mei₂ xie₃ wan₂)
 but not write finish
 ‘I wrote the letter for an hour (but I didn’t finish it).’
- b. ??wo₃ zai₄ yi₁ ge₅ zhong₁tou₂ nei₄ xie₃ le₅ na₄ feng₁ xin₄
 I at one CL hour in write LE that CL letter
 (ke₃shi₄ mei₂ xie₃ wan₂)
 but not-have write finish
 intended: ‘I wrote the letter in an hour (but I didn’t finish it).’
- (36) a. *wo₃ xie₃ wan₂ na₄ feng₁ xin₄ xie₃ le₅ yi₁ ge₅ zhong₁tou₂
 I write finish that CL letter write LE one CL hour
 intended: ‘I finished writing the letter for an hour.’
- b. wo₃ zai₄ yi₁ ge₅ zhong₁tou₂ nei₄ xie₃ wan₂ le₅ na₄ feng₁
 I at one CL hour in write finish LE that CL
 xin₄
 letter
 ‘I finished the letter in an hour.’

As predicted, the monomorphemic verb *xie₃* ‘write’ is perfectly compatible with durative adverbials (i.e., *for an hour*), but sounds odd with frame adverbials (i.e.,

in an hour). My intuition is that the frame adverbial in the perfective aspect with a simple activity verb, e.g., (35b), violates the Gricean maxim of quantity (1975), i.e., make your contribution as informative as is required, but not more. A frame adverbial and the perfective aspect strongly suggest that the relevant activity reaches its natural end point, but yet a speaker would generally use a verbal compound to denote such a situation.⁸ The verbal compound *xie₃ wan₂* ‘write-finish’ behaves exactly as predicted—it is compatible only with frame adverbials.

The necessity of employing verbal compounds to express completion is not a property unique to Mandarin. Japanese (Ikegami, 1985), Hindi (Singh, 1998), and Thai (Koenig and Muansuwan, 2000), for example, exhibit a similar phenomenon whereby the incremental theme can be interpreted as not having been completely affected (in the relevant sense denoted by the verb). The following sentences illustrate this with verbs of consumption (from Singh, 1998):

- (37) a. *maãẽ ne aaj apnaa kek khaayaa aur baakii kal*
 I ERG today mine cake eat-PERF and remaining tomorrow
khaaũũgaa
 eta-FUT
 ‘I ate my cake today and I will eat the remaining part tomorrow.’ (Hindi)
- b. *watashi-wa keeki-o tabeta dakedo keeki-wa mada nokotteiru*
 I-NOM cake-ACC ate-PERF but cake-NOM still remains
 ‘I ate the cake but some of it still remains.’ (Japanese)

Just as in Mandarin, the use of a verbal compound, however, asserts that the event has reached its natural end. In the following examples, asserting the existence of leftover food triggers a contradiction:⁹

- (38) a. **maãẽ ne kek khaa liyaa, jo bacaa hae wo raam*
 I ERG cake eat take-PERF what remain is that Ram
khaayegaa
 eta-FUT
 intended: ‘I ate the cake and Ram will eat the rest.’ (Hindi)
- b. **watashi-wa keeki-o tabeteshimatta dakedo keeki-wa mada*
 I-NOM cake-ACC ate-finish-PERF but cake-NOM still
nokotteiru
 remains
 intended: ‘I ate the cake but some of it still remains.’ (Japanese)

Considering the evidence, behavior exhibited by incremental theme verbs in Mandarin, Japanese, Hindi, and other languages do not appear very strange. Accomplishments, after all, do have features of both activities and achievements: they are like

⁸The sentences sound even more odd without the perfective marker.

⁹In my own examples, I am careful to distinguish contradictory (#) from ungrammatical (*), but I have preserved original judgments by others in cited examples.

activities in that an extended agentive action is involved, and they are like achievements in that a change of state occurs as a result of the action. A simple explanation would be that in some languages, these two semantic components of accomplishments are encoded separately. As a result, a verbal compound, in which the second verb explicitly encodes the end point, is necessary to denote a telic event. Although I believe this to be the correct intuition, the reality is much more complex. In what follows, I will attempt to untangle the intricacies of this phenomenon in both Mandarin and English, but regardless of the explanation, the empirical facts still support the claims about Mandarin I have set forth in (6).

Interactions with the Nominal System

My claims regarding the lack of monomorphemic accomplishments in Mandarin predicts that the Chinese equivalent of *all* incremental theme verbs in English would pass the “contradiction test”, i.e., denying the natural end point of an event would not result in a contradiction. As Soh and Kuo (2001) note, this is not true:

- (39) a. #wo₃ zou₂tian₁ zuo₄ le₅ yi₁ ge₅ dan₄gao₄, ke₃shi₄ mei₂
 I yesterday make LE one CL cake but not-have
 zuo₄ wan₂
 make finish
 intended: ‘I baked a cake yesterday, but I didn’t finish it.’
- b. #wo₃ zou₂tian₁ zao₄ le₅ yi₁ zuo₄ qiao₂, ke₃shi₄ mei₂ zao₄
 I yesterday build LE one CL bridge but not-have build
 hao₃
 good
 intended: ‘I built a bridge yesterday, but I didn’t finish it.’

In Mandarin, one cannot assert the baking of a cake or the construction of a bridge in the perfective aspect unless the relevant entity is completed as a result of the action. To make matters more complicated, Soh and Kuo further note that the choice of direct object has an impact on the result of the contradiction test. As an example, compare (33) with (40).

- (40) a. #wo₃ zou₂tian₁ xie₃ le₅ yi₁ ge₅ zi₄, ke₃shi₄ mei₂
 I yesterday write LE one CL character but not-have
 xie₃ wan₂
 write finish
 intended: ‘I wrote a character yesterday, but I didn’t finish it.’
- b. #wo₃ zou₂tian₁ hua le₅ yi₁ ge₅ quan₅quan₅, ke₃shi₄ mei₂
 I yesterday paint LE one CL circle but not-have
 hua₄ wan₂
 paint finish
 intended: ‘I drew a circle yesterday, but I didn’t finish it.’

The above examples point to interactions between verbal predicates and the Mandarin nominal system. Soh and Kuo analyze the above phenomena along these lines: an incremental theme verb gains its completion reading not because the verb inherently encodes an accomplishment, but from semantic properties of the theme. They introduce the dichotomy “No Partial Object” (NPO) and “Allows Partial Object” (APO) as a fundamental semantic property of physical entities, following (Chan, 1996). NPO is the class of objects that cannot be considered an instance of the relevant object until the process of creation has culminated. An example of the NPO class is *yi₁ ge₅ dan₄gao₁* ‘a cake’, which cannot be considered a cake until it has been completely made, i.e., prior to completion, the “cake” is merely a pile of flour and sugar. Other members of the NPO class include *yi₁ zuo₄ qiao₂* ‘a bridge’, *yi₁ ge₅ zi₄* ‘a character’, *yi₁ ge₅ quan₅quan₅* ‘a circle’: an incomplete bridge is merely a pile of bricks (or concrete, steel, etc.), an incomplete character is merely a collection of strokes, and an incomplete circle is merely an arc. Thus, NPOs in the direct object position of a creation verb entails the completion of the object, which cannot be canceled without a contradiction—the ability to name an object of the NPO class presupposes its existence. In contrast, *yi₁ feng₁ xin₄* ‘a letter’ and *yi₁ fu₂ hua₄* ‘a picture’ belong to the APO class: a partially written letter can still be considered a letter, and a partially finished painting is still a painting. Different tolerances for partial objects (cf. Chan, 1996) may account for the differences between Mandarin and English incremental theme verbs.

The nominal system of Mandarin and Hindi interacts with verbal predicates in other interesting ways as well. If the incremental theme is a numeral object, for example, then the natural end point of the event cannot be negated:

- (41) a. *ta₁ kan₄ le₅ liang₃ ben₃ shu₁ (#ke₃shi₄ mei₂ kan₄ wan₂)*
 I read LE two CL book but not-have read finish
 ‘He read two books (#but didn’t finish them).’
- b. *us ne do gilaas biiyar pii (*par puurii nahii[~] pii)*
 he ERG two glasses beer drank-PERF but entire NEG
 drink-PERF
 ‘He drank two glasses of beer (*but did not drink all of it).’

Singh (1998) and Soh and Kuo (2001) have different theories to account for these facts. However, these intricate interactions between the verbal and nominal systems do not detract from my primary claim that events appearing at first sight to be accomplishments are in fact activities in Mandarin.

English Incremental Theme Verbs

In this section, I will argue that, upon closer examination, English incremental theme verbs actually behave quite like activities in Mandarin. I believe that the natural end point of an event is not encoded in the lexical entry of an English incremental theme verb, but rather arises out of an implicature, and as such, is cancelable.

Following Singh (1998), I classify incremental theme verbs into three distinct categories:

- (42) a. Non-modifying: read a letter, recite a poem
 b. Modifying: eat a cake, paint the wall
 c. Creating: build a house, draw a picture

For all three types, the internal argument “measures out” the respective event. For non-modifying verbs, the direct object is not affected by the event, whereas modifying verbs denote some change of state in the object. The third class of incremental theme verbs is the verbs of creation, whereby an entity comes into existence as a result of the action denoted by the event. Singh decomposes these three classes in terms of more primitive semantic features—total affectedness and independent existence—and demonstrates how they are relevant for the interpretation of incremental theme verbs in Hindi.

According to Dowty’s theory of lexical semantics, the event representation for the above three classes of accomplishments would be something like the following:

- (43) a. John eat the cake.
 [[John do something] CAUSE [BECOME [cake eaten]]]
 b. John read the letter.
 [[John do something] CAUSE [BECOME [letter read]]]
 c. John built the house.
 [[John do something] CAUSE [BECOME [house exists]]]

adapted from (Dowty, 1979:91)

The standard decomposition of accomplishments is into a bi-eventive structure comprised of two subevents, the first of which denotes the agentive activity (the cause), and the second of which denotes the result. Such an analysis, however, poses an interesting problem for my syntactically-grounded framework. Recast into my theory, the structure of an accomplishment would require three separate verbalizing heads, v_{DO} to license the activity, and a stacked v_{δ} - v_{BE} core:

(44) John wrote the letter.

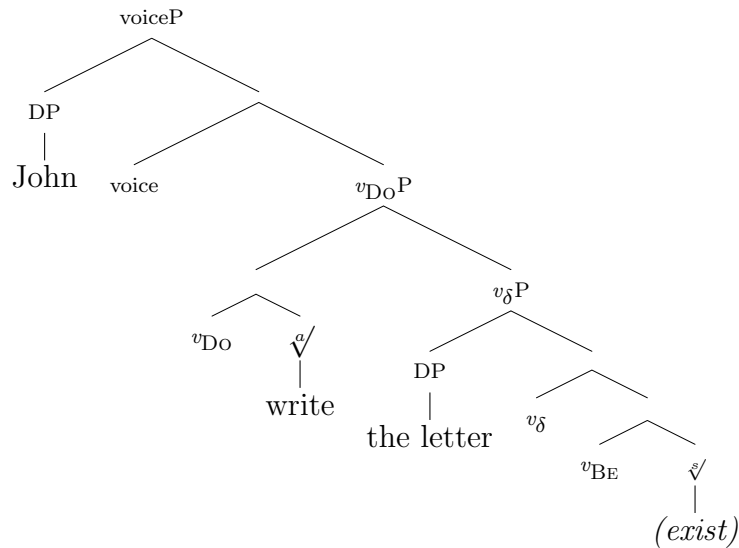

paraphrase: There is an activity of writing that causes the letter to come into existence, of which John is the agent.

There are at least three arguments against this analysis. If “John wrote the letter” does indeed have the above structure, then it would be syntactically indistinguishable from a prototypical change of state verb such as *break*. Clearly, however, these two classes of verbs behave quite differently.¹⁰

Another problem with the above analysis concerns the covert nature of the hypothetical stative root, whose meaning would be something like “exist”. To pursue this analysis, one would need to develop an independently-motivated theory of covert verbal roots. Even if the above structure were correct, this type of covert verbal compounding would be unique to creation verbs; a resultative construction in English is usually needed to encode the result of some activity, e.g., *hammer the metal flat*. In contrast, incremental theme verbs do not require result phrases, e.g., *write the letter to the end*, to encode the completion of the theme.

Finally, the structure presented in (44) incorrectly predicts the following sentences to be ungrammatical:

- (45) a. Mary ate a sandwich yesterday, but as usual she left the last bite.
 b. John built the cabinet last week, but he didn’t stain it yet.

If incremental theme verbs explicitly encode completion, then why are the above sentences perfectly acceptable? Going with the bi-eventive analysis, one could suggest the existence of two different verbs, *write* and *write+∅*, corresponding to completion and non-completion readings. This, however, merely begs the question: What licenses the hypothetical (covert) stative root, and why is it omissible? For these

¹⁰Note that this problem of different verb types having the same lexical semantic representation is not limited to my theory. In Rappaport Hovav and Levin’s (1998) framework of event templates, it is similarly difficult to distinguish event structures that are directly lexicalized by a monomorphemic verb and event structures that are derived via Template Augmentation.

reasons, Dowty's original analysis of incremental theme accomplishments appears to be untenable, especially when one carefully considers the syntactic implications of such an analysis.

Where then, does the completion reading come from? I argue that it arises from an implicature, and as such, can be canceled. The solution to the problem of English incremental theme verbs is to abandon the bi-eventive analysis completely. I give the following analysis to non-modifying incremental theme verbs:

(46) John read the poem.

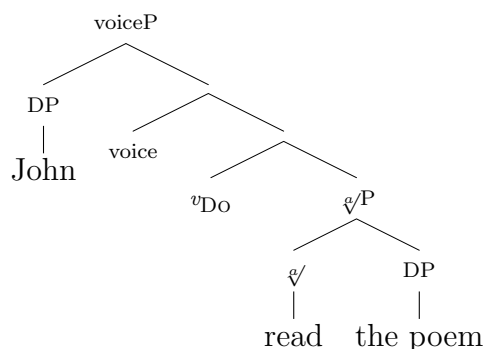

paraphrase: There is an activity of reading the poem, of which John is the agent.

Modifying and creating incremental theme verbs have the following structures, respectively:

(47) Mary ate the cake.

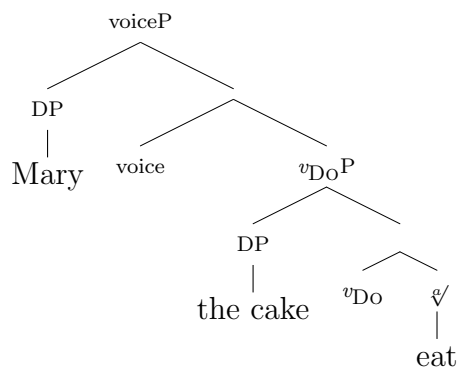

paraphrase: There is an activity of eating that acts on and causes an effect on the cake, of which Mary is the agent.

(48) Bill drew a picture.

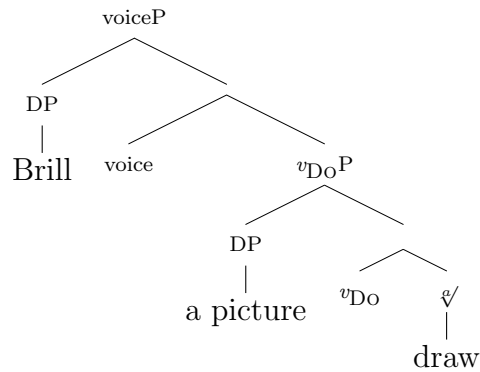

paraphrase: There is an activity of drawing that acts on and causes an effect on the picture, of which Bill is the agent.

In the case of non-modifying incremental theme verbs, the completion interpretation arises out of the relationship between the activity root and the idiosyncratic DP that it licenses. In the case of modifying and creating incremental theme verbs, the completion reading is the result of the interaction between the verbal root and the structural argument, which specifies the degree to which the object is affected. Critically, there is no v_{δ} present to license an inchoative event. Thus, the structure of incremental theme verbs is very different from that of prototypical change of state verbs such as *break*. I believe that the relationship between the verbal root and the argument of the verb can be captured in terms of the event-argument homomorphism model (Krifka, 1992, 1998), a further refinement of Dowty’s notion of incremental theme and Tenny’s Aspectual Interface Hypothesis. This model was developed to capture observations by Verkuyl (1972), who noted that the telicity of an event depends on the semantic properties of the internal argument:

- (49) a. John drank water for an hour/*in an hour.
 b. John drank a gallon of water *for an hour/in an hour.

With a definite amount of water, i.e., a *quantized* theme, the drinking event is interpreted as telic, but with an indefinite amount of water, i.e., a *cumulative* theme, the same event remains atelic. Under the event-argument homomorphism model, the boundedness property of the nominal argument is “transferred” over to the boundedness property of the event. More specifically, this is accomplished via a structure-preserving mapping, where each part of the incremental theme corresponds to a part of the event, and vice versa. Furthermore, the event’s start and end points must coincide with the start and end of the nominal argument (in the relevant sense denoted by the verb). In (49b), the gallon of water “measures out” the drinking event—when the water is half gone, the event is half over, and when the water is all gone, the event is over. The consumption of the gallon of water establishes temporal bounds on the activity of drinking, giving rise to a telic event. Since the water in (49a) is cumulative (i.e., a mass noun), no natural end point can be established for the corresponding event.

I argue that the completion reading in English incremental theme verbs arises naturally out of the event-argument homomorphism model. The structure-preserving mapping picks out the natural bounds in a quantized nominal by default, and hence the entire theme measures out the event. This, however, is not an absolute constraint, but can be violated. The effect is that natural end points of incremental theme verbs arise as implicatures, and as such, can be canceled:

- (50) a. John ate a sandwich yesterday, but as usual he left the last bite.
 b. John ate a sandwich yesterday, but as usual he didn't eat the crust.
 c. John ate a sandwich yesterday, but as usual he didn't eat the meat because he's a vegetarian.
 d. ?John ate a sandwich yesterday, but as usual he throws half the sandwich away.
 e. ??John ate a sandwich yesterday, but as usual he only takes a bite.
- (51) a. John read a book yesterday, but as usual he skips the footnotes.
 b. John read a book yesterday, but as usual he only reads the first and last chapters.
 c. ??John read a book yesterday, but as usual he only reads the first and last sentences.
 d. ??John read a book yesterday, but as usual he only reads the first and last words.
- (52) a. John wrote a letter yesterday, but he didn't sign it.
 b. John wrote a letter yesterday, but as usual he lets his assistant print it.
 c. ??John wrote a letter yesterday, but he didn't write the last paragraph yet.
- (53) a. John built a dog house yesterday, but he didn't paint it.
 b. John built a dog house yesterday, but he didn't write Spot's name over the door yet.
 c. ??John built a dog house yesterday, but he didn't put on the roof yet.

For modifying incremental theme verbs, e.g., (50), completion appears to be cancelable to the extent that the object can be regarded as having been affected in the relevant manner specified by the verbal root. The verbal root *eat* encodes an activity of consumption: to an English speaker, the activity of eating all but the last bite of the sandwich is “close enough” to the “typical” event of eating a sandwich. It is important to note that “typicality” is context dependent. For example, if Mary eats only half a sandwich for lunch everyday and saves the rest for later, it would not sound odd to say that “Mary ate her sandwich at lunch today”, even though she consumed only half of the sandwich.

For non-modifying incremental theme verbs and creating incremental theme verbs, completion appears to be cancelable to the extent that the theme can be considered an object of the type that it names. This relates to the partial object effect discussed previously. An unsigned letter is “close enough” to the prototype of a letter that denying the signature doesn’t result in a contradiction. In the same manner, an unpainted dog house can still be considered a dog house, but it would be a stretch to consider a roofless dog house an instance of a dog house.

In the same way that languages such as Mandarin and Hindi employ verbal compounds to specifically convey the attainment of the natural end point, English has a limited number of verb–particle constructions that fill the same role. As predicted, denying the natural end point of events denoted by these constructions sounds odd:

- (54) a. John ate a sandwich yesterday, but as usual he left the last bite.
 b. ??John ate up a sandwich yesterday, but as usual he left the last bite.

As I have shown, English incremental themes verbs behave more like their Mandarin and Hindi counterparts than one would initially believe. These verbs do not encode a bi-eventive structure, but rather denote a simple activity and convey an additional implicature.

2.4 Inchoativity

This section takes a closer look at change of state predicates in Mandarin and explores the origins of inchoativity. Although I have argued in the previous sections that achievements and accomplishments are derived from underlying activities via verbal compounding, it is not very difficult to construct apparent counterexamples to the hypothesis that Mandarin has no monomorphemic change of state verbs. Consider the following examples:

- (55) a. *shu*₄ *dao*₃ *le*₅
 tree fall LE
 ‘The tree fell.’
 b. *bo*₁*li*₂ *sui*₄ *le*₅
 glass shatter LE
 ‘The glass shattered.’

Unlike *xie*₃ ‘write’ and *hua*₄ ‘paint’, which are perfectly acceptable in the contradiction construction (33), *dao*₃ ‘fall’ and *sui*₄ ‘shatter’ are both semantically and grammatically odd:

- (56) a. #??*shu*₄ *zou*₂*tian*₁ *dao*₃ *le*₅, *ke*₃*shi*₄ *mei*₂ *dao*₃ *wan*₂
 tree yesterday fall LE but not-have fall finish
 intended: ‘The tree fell yesterday, but it didn’t finish falling.’

- b. #??bo₁li₂ zou₂tian₁ sui₄ le₅, ke₃shi₄ mei₂ sui₄ wan₂
 glass yesterday shatter LE but not-have shatter finish
 intended: ‘The glass shattered yesterday, but it didn’t finish shattering.’

Although it is unclear what *dao*₃ *wan*₂ ‘fall finish’ or *sui*₄ *wan*₂ ‘shatter finish’ could mean, the first clause of both (56a) and (56b) appear to encode an end state. For example, if one asserts that the tree has fallen, the fallen state of the tree cannot be denied without triggering a contradiction. This provides strong evidence against the hypothesis that Mandarin has only activity and state verbs; *dao*₃ ‘fall’ and *sui*₄ ‘shatter’ appear to explicitly encode end states, and hence must be either accomplishments or achievements.

If my original claims are correct, then the sentences in (55) cannot contain only simple verbs, but rather must be verbal complexes derived from either states or activities. I will argue, in fact, that this is exactly the case—inchoative predicates in Mandarin are derived from underlying stative verbs. This point will be made by a series of minimal pairs that contrast stative and change of state readings. Consider the first example:

- (57) a. *shu*₄ *gao*₁ *shi*₂ *gung*₁*fen*₁
 tree tall ten centimeter
 ‘The tree is ten centimeters tall.’
 b. *shu*₄ *gao*₁ *le*₅ *shi*₂ *gung*₁*fen*₁
 tree tall LE ten centimeter
 ‘The tree grew ten centimeters.’

In (57a), *gao*₁ ‘tall’ is used as a state, i.e., *be tall*, whereas in (57b), *gao*₁ is used as a change of state, i.e., *become tall(er)* or *grow*. Since the only difference between the pair is *le*, the particle must somehow contribute the inchoative component of meaning.

The distinct state and change of state readings are also apparent in minimal pairs involving questions:

- (58) a. *shu*₄ *gou*₁ *ji*₃ *gung*₁*fen*₁
 tree tall how.many centimeter
 ‘How tall is the tree in centimeters?’
 b. *shu*₄ *gou*₁ *le*₅ *ji*₃ *gung*₁*fen*₁
 tree tall LE how.many centimeter
 ‘How many centimeters has the tree grown?’

Once again, the only difference between the pair of questions in (58) is the presence or absence of the particle *le*. Therefore, it must contribute the semantic component of inchoativity.

More evidence for my claim can be found in the distinction between stative and the resultative participial forms of the underlying stative verb:

- (59) a. *sui*₄ (*de*₅) *bo*₁ *li*₂
 shattered DE glass
 ‘shattered glass’ (stative)
- b. *sui*₄ *le*₅ *de*₅ *bo*₁ *li*₂
 shattered LE DE glass
 ‘glass that was shattered’ (resultative participle)

The noun phrase in (59a) represents the stative form of *sui*₄ ‘shatter’; it simply denotes glass in a shattered state, i.e., in little pieces. In contrast, (59b) demonstrates the use of *sui*₄ as a resultative participle, i.e., participles that denote a state resulting from a prior event (cf. Embick, 2002). The difference between the two uses is quite distinct: (59a) denotes a state, whereas (59b) presupposes a prior inchoative event. Since the two noun phrases in Mandarin form a minimal pair differing only in the presence or absence of the particle *le*, it must contribute the semantic meaning of *to become X*. This contrast exactly parallels the following examples in English:

- (60) a. an open door
 b. an opened door

The analysis of *le* as a signal of inchoativity (among other uses) resolves a puzzle in the literature surrounding the Chinese verb *you*₃ ‘have’, typically thought to be a stative verb. Consider the following examples:

- (61) a. *Zhang*₁ *san*₁ *you*₃ *yi*₁ *da*₄ *bi*₃ *qian*₂
 Zhangsan has one big amount money
 ‘Zhangsan has a lot of money.’
- b. *Zhang*₁ *san*₁ *you*₃ *le*₅ *yi*₁ *da*₄ *bi*₃ *qian*₂
 Zhangsan has LE one big amount money
 ‘Zhangsan has acquired a lot of money.’

Sentence (61b) clearly denotes an inchoative event, and given the minimal pair, the particle *le* once again must be the source of the reading.

If we adopt the analysis of *le* as a marker of inchoativity, then the puzzle surrounding *you*₃ ‘have’ is easily resolved: it is inherently a stative verb, but becomes a change of state predicate with the addition of *le*. The ungrammaticality of *hen*₃ ‘very’ with *le* lends further support to this argument:

- (62) a. *Zhang*₁ *san*₁ *hen*₃ *you*₃ *qian*₂
 Zhangsan very has money
 ‘Zhangsan has a lot of money (Zhangsan is very rich).’
- b. **Zhang*₁ *san*₁ *hen*₃ *you*₃ *le*₅ *qian*₂
 Zhangsan very has LE money
 intended: ‘Zhangsan has acquired a lot of money.’

The Mandarin intensifier *hen*₃ ‘very’ can only co-occur with states: the ungrammaticality of (62b) indicates that the verb complex *you*₃ *le*₅ is no longer a stative predicate.

My analysis makes verifiable predictions regarding the interaction of *you*₃ and verbal *le* with temporal adverbials such as *at two o’clock*. If verbal *le* serves to convert a state into a change of state, then *at two o’clock* would indicate the point at which the new state (e.g., of being rich) is attained. Thus, it would be contradictory to assert that the state held *before* two o’clock. On the other hand, no such restriction exists with a pure state: if Zhangsan is in a particular state at a particular time, it should not trigger a logical contradiction to assert that he was also in that same state at a previous time. Indeed, this prediction is borne out (examples from Gao and Soh, 2003):

- (63) a. *Zhang*₁*san*₁ *xia*₄*wu*₃ *liang*₃ *dian*₃ *you*₃ *wu*₂ *bai*₃ *kuai*₄.
 Zhangsan afternoon two o’clock has five hundred dollar
*liang*₂ *dian*₃ *yi*₃*qian*₂ *ta*₁ *ye*₃ *you*₃ *wu*₂ *bai*₃ *kuai*₄
 two o’clock before he also have five hundred dollar
 ‘Zhangsan had five hundred dollars at two o’clock. Before two o’clock he also had five hundred dollars.’
- b. #*Zhang*₁*san*₁ *xia*₄*wu*₃ *liang*₃ *dian*₃ *you*₃ *le*₅ *wu*₂ *bai*₃
 Zhangsan afternoon two o’clock has LE five hundred
*kuai*₄. *liang*₂ *dian*₃ *yi*₃*qian*₂ *ta*₁ *ye*₃ *you*₃ *wu*₂ *bai*₃ *kuai*₄
 dollar two o’clock before he also have five hundred dollar
 intended: ‘Zhangsan acquired five hundred dollars at two o’clock. Before two o’clock he also had five hundred dollars.’

Once again, the only difference in the minimal pair (63) is the absence or presence of *le*; thus, it must contribute the component of inchoativity that gives rise to the different semantic interpretations.

To provide additional evidence for my analysis, let us examine juxtaposed state and change of state sentences and consider what predictions could be made:

- (64) a. *wo*₃ *kan*₄ *jian*₄ *shu*₄ *dao*₃ *zhai*₄ *lu*₄ *bian*₁
 I see perceive tree fall at road side
 ‘I see the fallen tree at the side of the road.’
- b. *wo*₃ *kan*₄ *jian*₄ *shu*₄ *dao*₃ *le*₅ *zhai*₄ *lu*₄ *bian*₁
 I see perceive tree fall LE at road side
 ‘I see the tree falling at the side of the road.’

Since I argue that the embedded clause in (64a) denotes a state, and the embedded clause in (64b) denotes a change of state, my analysis makes the following prediction: the speaker of (64b) must have witnessed the actual falling of the tree, whereas the speaker of (64a) might not have, i.e., the tree may have already fallen prior to arrival. This prediction is indeed borne out, most evidently when the sentences are shifted to the past tense:

- (65) a. *wo*₃ *zou*₂*tian*₁ *kan*₄ *jian*₃ *shu*₄ *dao*₃ *zhai*₄ *lu*₄ *bian*₁
 I yesterday see perceive tree fall at road side
 ‘Yesterday I saw the fallen tree at the side of the road.’ (the tree might have fallen last week)
- b. *wo*₃ *zou*₂*tian*₁ *kan*₄ *jian*₄ *shu*₄ *dao*₃ *le*₅ *zhai*₄ *lu*₄ *bian*₁
 I yesterday see perceive tree fall LE at road side
 ‘I saw the tree fall at the side of the road.’

Sentence (65a) expresses the situation where the speaker encountered a fallen tree lying by the side of the road yesterday—no commitment is made to when the tree fell. In contrast, example (65b) asserts that the speaker actually witnessed the falling of the tree yesterday, i.e., the change of state.

Although I claim that Mandarin change of state predicates are derived from underlying stative verbs, there may be a few genuine exceptions. For example, *de*₂ ‘get’ and *ying*₂ ‘win’ appear to convey a change of state reading without *le*. Consider the following examples:

- (66) a. *ta*₁ *de*₂ *jian*₃ *?(le)*₅
 he get award LE
 ‘He won the award.’
- b. *ta*₁ *de*₂ *le*₅ *jian*₃
 he get LE award
 ‘He won the award.’

I currently do not have a good explanation for this class of apparent counterexamples in Mandarin.

In the preceding pages, I have established a relationship between the particle *le* and change of state readings. The addition of verbal *le* to stative verbs in Mandarin gives rise to an inchoative interpretation. With possibly a few genuine exceptions, the particle appears to function as a marker of inchoativity.

2.5 Activities or States?

Although the contrast between activity and stative verbs is for the most part intuitively obviously to the native speaker, there are a few ambiguous cases that require more clear-cut diagnostics. Throughout this chapter, I have employed the contradiction test to distinguish states from activities: since activities are atelic events, any natural endpoint (if one exists) can be denied through a conjoined clause. States (and achievements derived therefrom) do not share this property.

Here I would like to propose an additional diagnostic that is a bit more compact. In the A-not-A construction, the contrast between states and activities is very transparent:

- (67) a. *pao₃/he₁/wan₂/tui₁ bu₄ pao₃/he₁/wan₂/tui₁*
 run/drink/play/push no run/drink/play/push
 ‘Are you going to run/drink/play push or not?’
- b. *gao₁/chang₂/hong₂/mang₂/lei₄ bu₄ gao₁/chang₂/hong₂/mang₂/lei₄*
 tall/long/red/busy/tired no tall/long/red/busy/tired
 ‘Are you/is it tall/long/red/busy/tired or not?’

In this construction, the dynamic nature of activity verbs is rendered very salient, such that they must be translated as “Are you going to *V* or not?” Stative verbs in the A-not-A construction, on the other hand, inquire about the stable properties of an entity. Although the diagnostic is not based on grammaticality judgments, this contrast is obvious to native speakers.

There are, however, verbs that do not appear to be grammatical in the A-not-A construction. Consider the following example:

- (68) *??dao₃/si₃/zhui₄/sui₄ bu₄ dao₃/si₃/zhui₄/sui₄*
 fall/die/drunken/shatter no fall/die/drunken/shatter
 intended: ‘Are you going to fall/die/get drunk or not?’

Since the above examples fail the contradiction test, one is inclined to believe that they represent states. They are, however, not acceptable in the A-not-A construction. Furthermore, if an interpretation had to be forced, the above verbs are able to marginally denote an activity, given the right circumstances. For these cases, the have-not-have construction renders salient the properties we are after:

- (69) *you₃ mei₂ you₃ dao₃/si₃/zhui₄/sui₄*
 have not have fall/die/drunken/shatter
 intended: ‘Is it/he fallen/dead/drunken/shattered?’

To a native speaker, these verbs obviously denote states, and do not implicate a dynamic eventuality of any sort. Contrast the reading of activity verbs in the have-not-have construction:

- (70) *you₃ mei₂ you₃ pao₃/he₁/wan₂/tui₁*
 have not have run/drink/play/push
 intended: ‘Did you/he run/drink/play/push?’

In summary, a combination of three tests is sufficient to distinguish activities from states: the contradiction test, the A-not-A test, and the have-not-have test. The latter two tests render salient the dynamic property of activities, making them “more activity-like” than they otherwise would be. This allows native speakers to better bring their intuitions to bear.

2.6 Accomplishments or Achievements?

Are Mandarin change of state predicates achievements or accomplishments? This section will explore this question in greater detail, and also provide a sketch of the organization of the Mandarin verbal system. Specifically, I will show that verbal *le* converts states into achievements, and accomplishments are further derived through verbal compounding in which the achievement “picks up” an activity verb. The situation can be summarized as follows:

- (71) **primitive event types:** state, activity
state + *le* → achievement
activity + achievement → accomplishment

The central concern of this section is the status of the following sentences: are they accomplishments or achievements?

- (72) a. *Li₃si₄ pang₄ le₅ liang₃ gong₁jing₁*
Lisi fat LE two kilograms
'Lisi gained two kilograms.'
b. *bo₁li₂ sui₄ le₅ man₃ di₄*
glass shatter LE whole floor
'The glass shattered all over the floor.'

The “progressive test” has frequently been cited as a diagnostic for distinguishing stative and non-stative verbs in English (Lakoff, 1966); only non-statives can occur in the progressive:

- (73) a. *John is knowing the answer. (state)
b. John is dancing. (activity)
c. John is painting a picture. (accomplishment)

Achievements, however, present a more complex story:

- (74) a. John is winning the game. (achievement)
b. ?John is reaching the top. (achievement)
c. ??John is noticing the sign. (achievement)

Since achievements are punctual, Smith (1991) argues that the progressive refers to the preliminary stages of the event leading up the change of state rather than the change of state itself. I will simply assume that the compatibility of English achievements with the progressive varies by verb. Despite this ambiguity, the progressive test will still be useful in ascertaining the event classification of the Mandarin sentences in (72).

Another useful test for separating achievements from accomplishments is the acceptability of the verb as the complement of *stop*:

- (75) a. Mary stopped knowing the answer. (state)
 b. Mary stopped dancing. (activity)
 c. Mary stopped painting a picture. (accomplishment)
 d. ??Mary stopped reaching the top. (achievement)

Achievements sound odd as the complement of *stop*, expect perhaps in a habitual interpretation, e.g., “John stopped noticing the sign.” The results of these two diagnostics are summarized below:

	<i>compatible with progressive?</i>	complement of <i>stop</i>
state	no	ok
(76) activity	yes	ok
accomplishment	yes	ok
achievement	maybe (^{ok} is winning, *is noticing)	bad

We can now apply these diagnostics to Mandarin sentences. As it turns out, the sentences in (72), as well as all derived change of state predicates in Chinese, appear to be incompatible with the progressive and as the complement of *stop*:

- (77) a. **Li₃si₄ zheng₄zai₄ pang₄ le₅ liang₃ gong₁jing₁*
 Lisi in.process.of fat LE two kilograms
 intended: ‘Lisi is in the process of gaining two kilograms.’
- b. **bo₁li₂ zheng₄zai₄ sui₄ le₅ man₃ di₄*
 glass in.process.of shatter LE whole floor
 intended: ‘The glass is in the process of shattering all over the floor.’
- (78) a. **Li₃si₄ ting₂zhi₃ pang₄ le₅ liang₃ gong₁jing₁*
 Lisi stop fat LE two kilograms
 intended: ‘Lisi stopped gaining two kilograms.’
- b. **bo₁li₂ ting₂zhi₃ sui₄ le₅ man₃ di₄*
 glass stop shatter LE whole floor
 intended: ‘The glass stopped shattering all over the floor.’

From the results in (76), we can conclude that the events in (72) are achievements. Change of state predicates derived from underlying stative verbs in Mandarin thus denote achievements.

Another interesting property of Mandarin verbs is the inability of achievements to directly transitive into a causative change of state form. Some verbs sound odd in this form, while others are outright ungrammatical:

- (79) a. **Zhang₁san₁ dao₃ le₅ shu₄*
 Zhangsan fall LE tree
 intended: ‘Zhangsan chopped the tree down.’

- b. *??Zhang₁san₁ sui₄ le₅ bo₁li₂*
 Zhangsan shatter LE glass
 intended: ‘Zhangsan shattered the glass.’

In order to express the intended meaning of the above sentences, Mandarin speakers must employ resultative verb compounds. In such a compound, the first verb denotes an activity and the second verb denotes a state that bounds the otherwise atelic activity:

- (80) a. *Zhang₁san₁ kan₃ dao₃ le₅ shu₄*
 Zhangsan chop fall LE tree
 ‘Zhangsan chopped the tree down.’
 b. *Zhang₁san₁ da₃ sui₄ le₅ bo₁li₂*
 Zhangsan hit shatter LE glass
 ‘Zhangsan shattered the glass.’

Such constructions are, in fact, accomplishments in Mandarin. They do allow the progressive, although the sentences sound much more natural in the *ba* construction:

- (81) a. *Zhang₁san₁ zheng₄zai₄ ba₃ shu₄ kan₃ dao₃*
 Zhangsan in.process.of BA tree chop fall
 ‘Zhangsan is chopping the tree down.’
 b. *Zhang₁san₁ zheng₄zai₄ ba₃ bo₁li₂ da₃ sui₄*
 Zhangsan in.process.of BA glass hit shatter
 ‘Zhangsan is shattering the glass.’

The next chapter will be devoted to a detailed analysis of resultative verb compounds, which are vastly more complex than the brief sketch presented here. Relevant issues I will explore include: What is the result predicated of? Which verb is the object an argument of? Which verb is the external argument an argument of? I will present a unified typological and syntactic analysis of Mandarin resultative verb compounds that accounts for a broad range of empirical facts.

Note, however, there exists a special class of verbs in Chinese that can freely undergo the causative/inchoative alternation without taking an activity verb in a resultative verb compound:

- (82) a. *da₄men₂ guan₁ le₅*
 door close LE
 ‘The door closed.’
 b. *Li₃si₄ guan₁ le₅ da₄men₂*
 Lisi close LE door
 ‘Lisi closed the door.’

- (83) a. *che₁zi₅ ting₂ le₅*
 car stop LE
 ‘The car stopped.’
- b. *Wong₂wu₅ ting₂ le₅ che₁zi₅*
 Wongwu stop LE car
 ‘Wongwu stopped/parked the car.’

The inchoative versions of these sentences are achievements, much like the examples in (72). However, I currently have no good explanation why this special class of verbs can undergo causativization without overt verbal compounding. Perhaps the resultative verb compound formation is occurring covertly, i.e., the activity verb in these cases are phonologically empty, as is the case with English. I leave this issue for further study.

The above class of verbs notwithstanding, the Mandarin verbal system appears to have clearly defined, regular processes for compositionally building event and argument structure from smaller components of meaning. Chinese verbs belong to either one of two primitive types, state or activity. Inchoative achievements derive from stative verbs with the addition of verbal *le*, and most inchoative achievements causativize into accomplishments by taking an additional activity verb as part of a resultative verb compound.

2.7 Stative Verbs and the Perfective Aspect

Evidence presented in the previous sections demonstrates that the addition of verbal *le* to a stative verb results in an achievement. The naïve explanation of this phenomenon is to simply posit that verbal *le* is an overt realization of v_{δ} . Such a claim, however, immediately raises a number of issues. Why does the inchoative *le* and the perfective *le* have the same phonological matrix? Inchoativity is a notion concerning situational (lexical) aspect, whereas perfectivity is a notion concerning viewpoint aspect—two unrelated concepts operating at different levels of syntactic structure. To simply posit that verbal *le* is (among other things) v_{δ} does not provide a satisfactory explanation to this important question.

Furthermore, it has been noted that, cross-linguistically, the same form used to mark the perfective aspect is often used to signal the inception of a new state with stative verbs, i.e., a change of state (Chung and Timberlake, 1985:217; Comrie, 1976:19). Comrie provides examples from Ancient Greek: the Aorist form (perfective past) of the verb *basileúō* ‘I reign’ can refer to a complete reign, or the start of the reign, as in *ebasíleusa* ‘I became king, ascended the throne’. This contrasts with the Imperfect (imperfective past) form *ebasíleuon*, which means ‘I was king’.

Consider the following examples from Russian, where stative verbs become change of state verbs when viewed perfectly:

(84)	<i>imperfective</i>		<i>perfective</i>
	ponimat’	‘understand’	ponjat’ ‘come to understand’
	verit’	‘believe’	poverit’ ‘come to believe’
	lubit’	‘love’	polubit’ ‘come to love’

The same phenomenon is also exhibited by French with the Imparfait/Passé Simple contrast. Imparfait is the imperfective past form, whereas Passé Simple represents the perfective past.

- (85) a. *Anne était triste.*
 Anne be-PAST-IMP sad
 ‘Anne was sad.’
- b. *Anne fut triste.*
 Anne be-PAST-PERF sad
 ‘Anne became sad.’
- (86) a. *Jeanne savait la reponse.*
 Jeanne be-PAST-IMP the answer
 ‘Anne knew the answer.’
- b. *Sudain, Jeanne sut la reponse.*
 Suddenly Jeanne know-PAST-PERF the answer
 ‘Suddenly, Anne came to know the answer.’

It is certainly no coincidence that the same form used to mark perfectivity is also used to signal inchoativity with stative verbs cross-linguistically. This points to a deeper underlying connection between the two functions, one that can not be satisfactorily explained by merely positing two distinct morphemes.

A theory that posits multiple morphemes having different functions, but the same phonological realization, presents a challenge for children acquiring language. Children make use of functional morphemes, which form a closed-class, to bootstrap the syntax and semantics of other sentential elements. For example, Poeppel and Wexler (1993) show that German children acquire the major functional and sentential heads, including the inflectional and complementizer systems, at a relatively early age. It is unclear how learners can bootstrap language using functional elements if they themselves are ambiguous.

From a variety of perspectives, having one morpheme for verbal *le* is preferred over positing multiple morphemes. Since there is some agreement among Chinese linguists that verbal *le* is a perfective marker,¹¹ an ideal analysis should explain why cross-linguistically, the combination of the perfective aspect with a stative verb gives rise to a change of state reading. Before presenting my own account, I will discuss the empirical challenges faced by a theory of “perfective states”.

I assume Klein’s (1994) model of aspect as logical relationships between the interval of time during which an event takes place (the situation time, abbreviated TSit)

¹¹Shi (1990) and J.-W. Lin (2003), however, present alternative accounts.

and the time interval about which a sentence makes an assertion (topic time, abbreviated TT). In this model, the perfective can be defined as $TSit \subset TT$, the temporal configuration where situation time is contained in topic time. In addition, I employ Dowty’s definition of states:

- (87) If α is a stative predicate, then $\alpha(x)$ is true at all moments within I . (Dowty, 1979:166)

Given these assumptions, a state viewed perfectively is predicted to have the interpretation described by the following diagram:

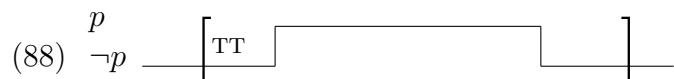

With the perfective aspect, situation time must be contained in topic time. This means that there must exist an interval near the beginning of the topic time and near the end of the topic time in which the state does not hold. Languages, however, do not appear to behave this way. Consider the following French examples:

- (89) a. *Hier, Anne fut triste.*
yesterday Anne be-PAST-PERF sad
‘Anne became sad yesterday.’
a. *Hier, Jeanne sut la reponse*
yesterday Jeanne be-PAST-PERF the answer
‘Anne came to know the answer yesterday.’

Critically, native speakers do not get from (89a) the reading, say, that sometime yesterday morning Anne became sad, but she got over it and was happy again yesterday afternoon. Similarly, the diagram in (88) does not describe the interpretation of (89b).

Although the change of state reading that arises from the combination of the perfective aspect and stative verbs has been long observed, few satisfactory treatments have been proposed. Analyses of this mystery and related phenomena based on aspectual coercion have been proposed (cf. Moens and Steedman, 1988). In particular, de Swart (1998; 2000) describes a theory of aktionsart-aspect interactions based on coercion operators within the framework of Discourse Representation Theory (Kamp and Reyle, 1993). These operators come into play in the semantic composition when and only when a type clash licenses them; in her own words: “Coercion ... is governed by implicitly contextual reinterpretation mechanisms triggered by the need to resolve aspectual conflicts” (de Swart, 1998:360). These operators are introduced as underspecified semantic functions (from sets of eventualities to sets of eventualities) which can be resolved to a number of distinct aspectual operators. For example, a telic-to-atelic semantic function can be resolved to the progressive, the iterative, or the habitual.

However, Bonami (2001) convincingly demonstrates that de Swart’s implementation of aspectual coercion is inadequate. In particular, some implicit operators are

licensed even when no type clash licenses them. If aspectual coercion is not licensed by semantic mismatch, then what constrains their distribution? Since coercion operators do not have surface realization, why can't they be arbitrarily "chained" to produce different interpretations? In addition, Bonami shows that the presence of a given implicit operator is not licensed in some cases even though it would resolve a type clash.

My analysis of "perfective states" centers on the covert inchoativizing head, i.e., v_δ . As I have previously demonstrated, languages such as O'odham, Quechua, and English appear to have overt inchoativizing suffixes that convert states into change of states. There is no reason why this morpheme must be overt. In fact, *clear*, *dim*, *tame*, and many other deadjectival verbs in English are formed by a zero-affix. The solution I propose for the "perfective state" mystery is the presence of a covert inchoative verbalizing head v_δ that gives rise to the change of state reading. With this functional element in place, the perfective aspect behaves exactly according to the standard definition, i.e., indicating the temporal configuration where situation time is contained in topic time.

The following time-course diagram captures the interpretation of a stative verb viewed perfectly:



Once a state is converted into a change of state by v_δ , the perfective marker *le* can apply to the resulting event in the usual way, i.e., to denote the viewpoint wherein the situation time (the transition from $\neg p$ to p) is wholly contained in the topic time. In principle, it does not matter whether the transition is punctual or gradual, as long as the entire transition is contained within topic time.

Given this analysis, I believe that the proper syntactic structure of (91) is shown in (92):

- (91) $ta_1 \quad gao_1 \quad le_5 \quad san_1 \quad gong_1 fen_1$
 I tall LE three centimeter
 'He grew three centimeters.'

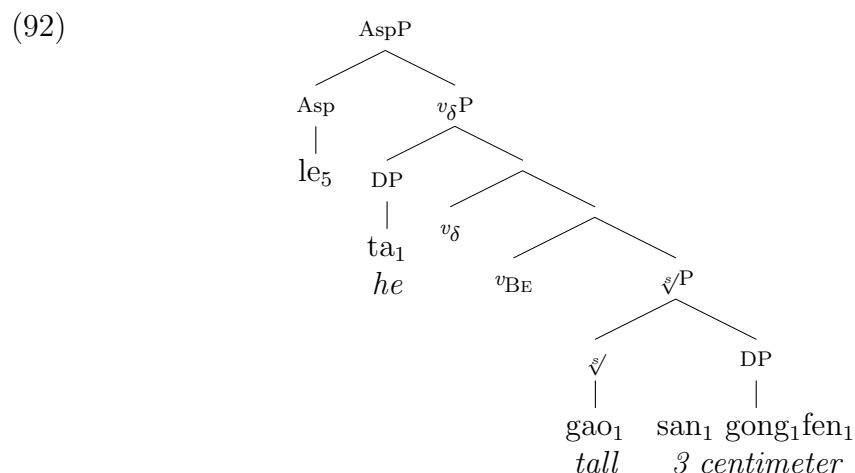

This analysis of verbal *le* predicts that it is possible to have a change of state reading even in the absence of the particle. This is indeed borne out:

- (93) a. *Li₃si₄ xian₃ pang₄ san₃ gong₁jing₁*
 Lisi think fat three kilogram
 ‘Lisi wants to gain three kilograms.’
- b. *ta₂ mei₃ nian₂ gao₁ yi₁ gung₁fen₁*
 he every year tall one centimeter
 ‘He grows a centimeter every year.’
- c. *ni₃ chou₁ yan₁, hui₄ zhao₃ si₃*
 you inhale smoke, will early die
 ‘If you smoke, you’ll die young.’

Thus, verbal *le* is not considered the overt realization of v_δ , but rather a surface reflex of the underlying verbalizing head. This analysis captures the correct generalizations without stipulating a new semantic function for the particle. As I have shown, the presence of v_δ is independently motivated.

2.8 Conclusion

The primary goal of this chapter is to provide supporting evidence for my theory of verbal argument structure. I have shown that the organization of the Mandarin verbal system transparently mirrors the theoretical framework I have posited. It can be seen that event and argument structure is syntactically composed from stative roots, activity roots, and an inventory of three verbalizing heads. In the following chapter, I will take a closer look at the productive phenomenon of resultative verb compounds, which further highlights the process of event composition that I have been espousing.

Chapter 3

Mandarin Resultative Verb Compounds

The formation of resultative verb compounds is a productive process in Mandarin wherein a sequence of verbs collectively denote a complex event involving an activity and its result. These compounds have been related to serial verb constructions (SVCs) found in many languages (Nishiyama, 1998); see also (Baker, 1989; Collins, 1997; Baker and Stewart, 1999; Butt and Ramchand, 2001; Carstens, 2002). According to Collins' (1997) definition, Mandarin resultative verb compounds *are* instances of serial verb constructions:

(1) *Definition of SVC*

A serial verb construction is a succession of verbs and their complements (if any) with one subject and one tense value that are not separated by any overt marker of coordination or subordination. (Collins, 1997:462)

However, not all serial verb constructions are resultative in nature. Consider the following examples from Yoruba (2) and Ewe (3), both west African languages:

(2) Yoruba (Baker, 1989)

- a. *Ó mú ìwé wá.*
he take book come
'He brought the book.'
- b. *Bólá sè ẹ́ran tà.*
Bola cook meat sell
'Bola cooked some meat and sold it.'
- c. *Titi rìn lọ ni, kò sáré lọ.*
Titi walk go is not run go
'Titi left walking, not running.'

(3) Ewe (Collins, 1997)

- a. *Me nya dɛvi-ɛ dzo.*
I chase child-DEF leave
'I chased the child away.'
- b. *Kofi tsɔ ati-ɛ fo Yao.*
Kofi take stick-DEF hit Yao
'Kofi took the stick and hit Yao with it.'
- c. *Wo da fufu du.*
they cook fufu eat
'They cooked fufu and ate it.'

Beside expressing the direct result of an action, other common patterns of serial verb constructions involve temporal sequencing of events and composition of events that are not causally related. Since a comprehensive theory of all serializing constructions is beyond the scope of this work, I will limit my inquiry to resultatives only. Informally, resultative verb compounds in Mandarin are sequences of verbs that describe a complex event consisting of an activity and an end state, where one is the direct result of another. It is important to note, however, that some Mandarin verbal compounds are not resultative in nature; I call these spurious compounds, and will devote some attention to them in Sections 3.2 and 3.5.

In general, resultative constructions are cross-linguistically interesting because they encode complex events, which provide a good test for any theory of argument structure. I will demonstrate that Mandarin RVCs and English resultatives share the same underlying structure, except that in Mandarin, the result predicate is headed by a verb, whereas in English, results are denoted by adjectives or prepositional phrases. Differences between Mandarin and English resultative constructions can be primarily attributed to categorial difference of the result phrase. My goal in this chapter is to provide an account of resultatives that grounds complex events simultaneously in semantically-meaningful functional heads and independently-motivated syntactic principles.

In Mandarin resultative verb compounds, the arguments expressed by the entire compound is a product of the argument structure of the individual verbs. This mapping, however, is by no means obvious. Sometimes, arguments are "shared", i.e., an argument of the entire compound is a semantic argument of both individual verbs. Sometimes, arguments of the individual verbs remain unexpressed. Furthermore, in some cases, the external argument of the entire verbal compound may not be a semantic argument of either verb. It is a challenge of any theory to account for these facts, and it is my claim that the argument structure of RVCs are syntactically constructed.

3.1 Basic RVC Classification

In their influential work on Mandarin grammar, Li and Thompson (1981) classify Mandarin resultative verb compounds into three basic types: simple, phase, and directional. Almost all RVCs in Mandarin are comprised of two verbs (I will return to longer compounds shortly); for expository convenience, I will refer to the individual verbs as V_1 and V_2 .

The first type of resultative verb compound, *simple RVC*, is comprised of a two verb sequence where V_1 denotes an activity and V_2 denotes a state. The second verb describes the end state that is brought about by the V_1 event, and the entire verbal compound is necessarily telic. A few examples are shown below:

- (4) a. $Wu_3song_1 da_3 si_3 le_5 lao_3hu_3$
 Wusong hit die _{LE} tiger
 ‘Wusong beat the tiger to death.’
- b. $Zhang_1san_1 ti_1 fan_1 le_5 tong_3zi_5$
 Zhangsan kick spill _{LE} bucket
 ‘Zhangsan kicked the bucket over.’
- c. $Li_3si_4 ku_1 shi_1 le_5 shou_3pa_4$
 Lisi cry wet _{LE} handkerchief
 ‘Lisi cried the handkerchief wet.’

For greater accuracy, I refer to these constructions as *literal resultative verb compounds*, and the second verb as the literal result, because it is in a direct predication relationship with either the direct object or the subject¹ of the entire verbal compound—this means that the second verb can be used felicitously in a simple sentence, for example, (5). This parallels resultative constructions in English, where the adjective describes the state of affairs that results from the activity, as in (6).

- (5) a. $Wu_3song_1 da_3 si_3 le_5 lao_3hu_3$
 Wusong hit die _{LE} tiger
 ‘Wusong beat the tiger to death.’
- b. $lao_3hu_3 si_3 le_5$
 tiger die _{LE}
 ‘The tiger died.’

- (6) a. John pounded the metal flat.
 b. The metal is flat (as a result of John’s pounding).

Li and Thompson’s second type, *phase RVC*, expresses the completion of an event without supplying a literal result state:

¹Mandarin appears to violate the Direct Object Restriction (Levin and Rappaport Hovav, 1995); this issue will be discussed in detail later.

- (7) a. *Zhang₁san₁ zong₁yu₂ mai₄ diao₄ le₅ che₁zi₅*
 Zhangsan finally sell drop LE car
 ‘Zhangsan finally sold the car.’
- b. *Li₃si₄ zou₂tian₁ yi₃jing₁ zuo₄ hao₃ le₅ gong₁ke₄*
 Lisi yesterday already make good LE homework
 ‘Lisi already finished the homework yesterday.’
- c. *Wong₂wu₅ kan₄ wan₂ na₄ ben₃ shu₄ le₅*
 Wongwu read finish that CL book LE
 ‘Wongwu finished reading the book.’

In (7a), the second verb *diao₄*, literally ‘drop’, cannot be used to describe the state of the car as a result of the selling event. The situation is exactly the same for the other phase resultative verb compounds. Critically, the V_2 of a phase RVC is *not* a literal result, and cannot be used felicitously as the main verb in simple sentences to describe the end state. Contrast the following sentences to (5b):

- (8) a. **che₁zi₅ diao₄ le₅*
 car drop LE
 intended: ‘The car has been gotten rid of.’
- b. **gong₁ke₄ hao₃ le₅*
 homework good LE
 intended: ‘The homework has been finished.’
- c. **na₄ ben₃ shu₄ wan₂ le₅*
 that CL book finish LE
 intended: ‘that book has been finished.’

The second verb of these compounds are known in the literature as “phase complements”. According to Chao (1968:446), phase complements “express the phase of an action in the first verb rather than some result in the action or goal”. Li and Thompson (1981:65) remark that these morphemes express the degree to which an action is carried out, rather than the result. An important point to note is that phase RVCs are telic, and necessarily imply completion of the event in the relevant sense, that is, the natural end of the event is reached. Thus, these resultative verb compounds fail the contradiction test; conjoining a clause that denies the natural end point of the event results in a contradiction (see Section 2.3). In this fashion, phase RVCs in Mandarin are similar to verb–particle constructions in English, where the preposition contributes little semantic content, but primarily serves to delimit the event. Alternatively, one can view the phase complement as having a metaphoric or idiomatic interpretation. Despite the differences between literal and phase RVCs, I will argue that they share the same underlying structure. The process of incorporation (head movement) allows adjacent verbs to acquire idiomatic or metaphoric interpretations; when such movement is blocked, idiosyncratic meaning cannot be licensed (more on this in Section 3.8).

Although phase complements cannot be used to describe the literal result of an action when used in a resultative verb compound, they can nevertheless function as true verbs. A few common phase complements are shown in (9) and examples of them being used as main verbs in simple sentences can be seen in (10).

(9)	phase complement	verb meaning (as main verb)
	<i>cheng</i> ₂	‘success’
	<i>cuo</i> ₄	‘wrong’
	<i>dao</i> ₄	‘arrive’
	<i>diao</i> ₄	‘drop’
	<i>hao</i> ₃	‘good’
	<i>wan</i> ₂	‘finish’

- (10) a. *chian*₁ *bi*₃ *diao*₄ *le*₅
pencil drop LE
‘The pencil dropped.’ (i.e., onto the ground)
- b. *wo*₃ *de*₅ *shen*₁ *ti*₃ *hao*₃ *le*₅
I DE body good LE
‘I recovered from an illness.’
- c. *dian*₄ *ying*₃ *wan*₂ *le*₅
movie finish LE
‘The movie is over.’

An often-used diagnostic to distinguish between literal and phase RVCs is the *de* form of the resultative construction, where the object intervenes between V₁ and V₂. Literal resultative verb compounds can be paraphrased by the *de* construction, whereas phase resultative verb compounds cannot:

- (11) a. *Li*₃ *si*₄ *ku*₁ *shi*₁ *le*₅ *shou*₃ *pa*₄
Lisi cry wet LE handkerchief
‘Lisi cried the handkerchief wet.’ (literal RVC)
- b. *Li*₃ *si*₄ *ku*₁ *de*₅ *shou*₃ *pa*₄ *shi*₁ *le*₅
Lisi cry DE handkerchief wet LE
‘Lisi cried until the handkerchief got wet.’
- (12) a. *Wong*₂ *wu*₅ *kan*₄ *wan*₂ *na*₄ *ben*₃ *shu*₁ *le*₅
Wongwu read finish that CL book LE
‘Wongwu finished reading the book.’ (phase RVC)
- b. **Wong*₂ *wu*₅ *kan*₄ *de*₅ *na*₄ *ben*₃ *shu*₁ *wan*₂ *le*₅
Wongwu read DE that CL book finish LE
intended: ‘Wongwu read until the book was finished.’

Huang (1988) analyzes *de* as a complementizer, and hence the *de* variant of RVCs are bi-clausal. Sybesma (1999) presents a different analysis, arguing that *de* heads an “Extent Phrase” that intervenes between the projections of the activity and the result. The relationship between the canonical verbal compound form and the *de* alternation will be discussed in Section 3.8. For now, the analysis of *de* is irrelevant; what is important is its usefulness as a diagnostic for separating literal RVCs from phase RVCs.

Finally, Li and Thompson’s third type, *directional RVC*, is comprised of an activity verb followed by subsequent verbal elements that express spatial properties of the activity. These compounds productively, and quite naturally, can allow up to three verbal elements. Typical examples are shown below:

- (13) a. w_3 pao_3 guo_4 $qiao_2$ le_5
 I run over bridge LE
 ‘I ran over the bridge.’
- b. ta_1 na_2 $zhou_3$ le_5 shu_1 bao_1
 he take away LE book.bag
 ‘He took away the book bag.’
- c. ta_1 men_5 $tiao_4$ chu_1 lai_2 le_5
 they jump out come LE
 ‘They jumped out.’

I believe that these resultative verb compounds are merely specific instances of the first two types. Sentence (13a), for example, expresses a literal result; in this case, the result is predicated of the subject (more on this in Section 3.3.1). Consequently, the following sentence is perfectly natural:

- (14) w_3 guo_4 (le_5) $qiao_2$ le_5
 I over LE bridge LE
 ‘I crossed the bridge.’

Although guo_4 appears to be a directional verb, it is in actuality no different than any other stative verb in Mandarin, i.e., denoting the state of having crossed something.² This is confirmed by the contradiction test: it is contradictory to conjoin a clause denying the act of crossing the bridge. Thus, the sentence in (14) denotes a change of state, not an activity.

The example in (13b) belongs in the same category as phase resultative compound; V_2 does not describe a literal result of the book bag. The translation of the sentence into the verb–particle construction *take away* is very accurate, and captures much of the same nuances of the event (note, “*The book bag is away”). Finally, (13c) behaves like a literal resultative verb compound; it sounds perfectly grammatical with the first verb omitted:

²Like other verbs of spatial configuration, it licenses a reference entity, and thus has properties of a preposition.

- (15) *ta₁ men₅ chu₁ lai₂ le₅*
 they out come LE
 ‘They came out.’

The only complication with the RVC in (13c) is the predicate *lai₂*, best glossed as ‘come’, or perhaps ‘hither’. This predicate forms a complementary pair with *qu₄* ‘go’, or perhaps ‘thither’. It is unclear whether these morphemes are true verbs. Zhang (2001a) cites three main uses for *lai/qu*:

- (16) a. *Zhang₁ san₁ qu₄ guo₄ Xiang₁ Gang₃*
 Zhangsan go EXP Hong Kong
 ‘Zhangsan has been to Hong Kong.’
 b. *Li₃ si₄ lai₂ [xia₄ le₅ yi₁ pan₂ qi₂]*
 Lisi come play LE one CL chess
 ‘Lisi came to play a round of chess.’
 c. *Wong₂ wu₃ [kan₄ Zhang₁ san₁] lai₂ le₅*
 Wongwu see Zhangsan come LE
 ‘Wongwu came to see Zhangsan.’

In (16a), *qu₄* ‘go’ is used as a main verb. The predicates *lai₂* and *qu₄* can also either appear in front of an XP, as in (16b), or immediately following one, as in (16c). In both cases, the predicate does not appear to be verbal in nature. It is unclear whether the resultative in (13c) should be analyzed in the same manner as any of those in (16). Since there is yet no consensus on the treatment of these constructions, I will exclude them from my discussion of resultative verb compounds.

Resultative verb compounds in Mandarin consisting of three elements are rare, but not unheard of. Consider the following example:

- (17) *ta₁ ku₁ fan₂ si₃ le₅ wo₃*
 he cry annoy die LE me
 ‘He cried so much that I got annoyed to death.’

There is, however, reason to suspect that these tri-verbal constellations are not true resultative verb compounds.³ Evidence comes from the fact that *si₃* ‘die’ can be used semi-productively to intensify the effect of ordinary two-verb compounds. This fact leads one to suspect that *si₃* may not be a true verb in these cases; these instances are perhaps better analyzed as adverbs. Furthermore, there do not exist enough occurrences of natural-sounding three-element compounds (those with *si₃* aside) for me to form good intuitions about their underlying structure. It is similarly difficult to elicit clear-cut judgments from native speakers, for example, about possible and impossible scenarios that can be described by the compounds. For these reasons, three verb compounds will be excluded from my study.

Superficially, I claim that Mandarin resultative verb compounds can be divided into the literal type, where *V₂* describes the result of the action denoted by *V₁*, and the phase complement type, where the *V₂* is interpreted non-literally. The bi-clausal *de* form of resultative verb compounds is sensitive to this distinction.

³I am grateful to Alexander Williams (p.c.) for pointing this out.

3.2 Spurious Verbal Compounds

Not all consecutive sequences of verbs in Mandarin are resultative verb compounds. In this section, I will discuss state-state, activity-activity, and activity-state verbal combinations that are not resultative in nature; that is, V_2 does not describe the result of the event denoted by V_1 (not even under idiomatic or metaphoric interpretations). I call these spurious verbal compounds, distinguishing them from true resultative verb compounds.

A common type of non-resultative verb compound in Mandarin consists of two stative verbs. Consider the following examples:

- (18) a. *Zhang₁san₁ zhu_{i4} dao₃ le₅*
Zhangsan drunk fall _{LE}
'Zhangsan got so drunk he fell.'
- b. *Li₃si₄ lei₄ hui₄ le₅*
Lisi tired bad _{LE}
'Lisi got really tired.'
- c. *lao₃hu₃ si₃ diao₄ le₅*
tiger die drop _{LE}
'The tired died.'

The meanings of these verbal compounds are generally idiomatic, and cannot appear in the *de* construction. For example, Zhangsan does not literally have to fall in order for (18a) to be felicitous; *dao₃* 'fall' appears to have an intensification effect. In (18b), *hui₄* 'bad' does not describe the literal state of the subject, but is used to elaborate on the tired state. Finally, in (18c), there appear to be no truth-conditional differences between *si₃* 'die' and *si₃ diao₄* 'die drop'.

I believe that double-state compounds in Mandarin are similar to resultatives in English based on unaccusatives, such as those in (19). These matrix unaccusatives already denote a change of state, but they are able to further participate in resultative constructions. I only provide a descriptive characterization of the facts here; analysis of these compounds will be deferred until Section 3.5.

- (19) a. The pond froze solid.
b. The gate opened wide.
c. The vase broke into bits.

Paralleling double-state verbal compounds, there exist double-activity compounds in Mandarin. Consider the example in (20), from (Li, 1999:447). Note that the crying is not a result of the singing: there is no explicit causal relationship between the two activities. As an aside, the sentence sounds perfectly acceptable in the *de* construction.

- (20) *ta*₁ *chang*₄ *ku*₁ *le*₅
 he sing cry LE
 ‘He cried from singing.’ (e.g., because the song evoked sad memories)

Finally, there are Mandarin verbal compounds consisting of an activity and a state that are not resultative in nature. The following examples are adapted from (Li, 1999:479):

- (21) a. *ta*₁ *chang*₄ *hui*₄ *le*₅ *na*₄ *shou*₃ *ge*₁
 he sing know LE that CL song
 ‘He learned the song through singing it.’
 b. *wo*₃ *xia*₄ *ying*₂ *le*₅ *na*₄ *pan*₂ *qi*₂
 I play win LE that CL chess
 ‘I won that chess game.’
 c. *xue*₂ *sheng*₁ *men*₅ *ting*₁ *dong*₃ *le*₅ *ke*₄
 students listen understand LE class
 ‘The students understood the class material.’

Take (21b) as an example: the winning of the chess game does not result from the playing, i.e., the chess game is not affected by the activity in the same way as in a true resultative verb compound. In other words, “I played the chess game and won it as a result” is not a good paraphrase of the sentence. Contrast this with a true RVC such as “I ran myself exhausted”, which can be accurately paraphrased as “I ran and became exhausted as a result.” Interestingly, in these verbal compounds, the subject and the object appear to be semantic arguments of *both* verbs:

- (22) a. *wo*₃ *xia*₄ *le*₅ *na*₄ *pan*₂ *qi*₂
 I play LE that CL chess
 ‘I played that chess game.’
 b. *wo*₃ *ying*₂ *le*₅ *na*₄ *pan*₂ *qi*₂
 I win LE that CL chess
 ‘I won that chess game.’

As shown above, both *xia*₄ ‘play’ and *ying*₂ ‘win’ can be used as the main verb in a simple sentence with the same subject and object as in the RVC. The same is true for the other examples in (21): *V*₂ does not denote a result of the event denoted by *V*₁. The relation between the two eventualities is not causal in nature, but rather simply one of temporal precedence. These spurious compounds present additional challenges for a theory of argument structure.

3.3 Inventory of Issues

Before delving into a detailed syntactic account of Mandarin resultative verb compounds, I will first present a typological analysis of the phenomenon to highlight the range of empirical facts that any successful theory must account for. There are (at least) three dimensions in which resultative verb compounds in Mandarin can vary; for similar accounts of the English resultative, see (Rappaport Hovav and Levin, 2001; Goldberg and Jackendoff, 2003):

- (23)
- a. what argument the result is predicated of
 - b. which verb the direct object is an argument of
 - c. which verb the external argument is an argument of

Note that these variations only make sense with respect to literal resultatives verb compounds, which will be the focus of the discussion for now. I will return to the question of phase RVCs in Section 3.8.

In the following pages, I will examine each of these variations in greater detail. They, in essence, form the desiderata for a theory of Mandarin resultative verb compounds, and more generally, verbal argument structure. After this typological study, a detailed syntactic analysis will be presented.

Wherever relevant, I will point out the differences between Mandarin and English resultatives. The most obvious difference, of course, is the syntactic category of the result phrase itself: in Mandarin, it is always headed by a stative verb, while in English, the result phrase can either be an adjective or a prepositional phrase:

- (24)
- a. The chef rolled the dough flat.
 - b. The chef rolled the dough into pieces.

Since the result phrase in English is not verbal in nature, it cannot be used as the primary predicate in a simple sentence. This contrasts with Mandarin, where the literal result can be used as a main verb. I will later show that many differences between Mandarin and English resultatives can be traced to the categorial difference of the result phrase.

3.3.1 The Direct Object Restriction

Simpson (1983), in a study of the resultative construction, first noticed a restriction on the result phrase of a complex causative—it appears to always be predicated of the immediate post-verbal NP (cf. Carrier and Randall, 1992). Levin and Rappaport Hovav (1995) formalize this generalization into the Direct Object Restriction (DOR), a cornerstone of their exploration of unaccusativity. The DOR explains why, for example, unergatives cannot appear in a resultative construction without the insertion of a “fake reflexive object” to mediate the predicational relationship. The following prototypical examples of resultatives show the predication relation between the post-verbal object (i.e., “direct object”) and the result phrase:⁴

⁴In a sense, the DOR is a misnomer because the subject of predication is often not an actual direct object of the matrix verb.

- (25) a. John hammered the metal flat.
 b. Mary boiled the kettle dry.
 c. Alice shouted herself hoarse.
 d. Bob ran his Nikes threadbare.

The validity of the Direct Object Restriction has been an intensely debated issue. Wechsler (1997), for example, argues that the generalization is violated in the following English examples:

- (26) a. The wise men followed the star out of Bethlehem.
 b. The sailors rode the breeze clear of the rocks.
 c. He followed Lassie free of his captors.

(Wechsler, 1997:313)

In these cases, Wechsler argues that the result phrase appears to be predicated of the subject, i.e., the wise men rode out of Bethlehem as a result of the “following” event (but see below for discussion about the acceptability of such a paraphrase). He argues that the examples in (26) belong in the same class as the examples in (25). If this analysis is correct, then the Direct Object Restriction is not valid, and many theoretical results built upon this assumption need to be reexamined, e.g., the status of the resultative as a diagnostic of unaccusativity. Rapport Hovav and Levin (2001), in more recent work, concede Wechsler’s observations and subsequently abandon the Direct Object Restriction.

This recent development in denying the DOR in English may be premature. It has not escaped the attention of many linguists that Wechsler’s counterexamples are all complex events of directed motion. They form a natural semantic class, and it would not be far-fetched if such constructions behave differently from normal resultatives. The agreement paradigm of *Ambae*, an Oceanic language of Vanuatu, where complex predicates of directed motion behave differently than other complex causatives, provides suggestive evidence (Williams, 2002).

Furthermore, examples in (26) cannot be paraphrased in the same way as the examples in (25):

- (27) John caused the metal to be flat by hammering it. = (25a)
 (28) The wise men caused themselves to get out of Bethlehem by following the star. ≠ (26a)

Whereas (27) is a good paraphrase of (25a), (28) means something quite different than (26a). Given these considerations, the Direct Object Restriction may still be a valid generalization; see Williams (2002) for additional arguments against Wechsler’s analysis. Levin and Rappaport Hovav’s abandonment of the Direct Object Restriction is perhaps not warranted.

Although it may be debatable whether the examples in (25) and (26) form a homogeneous group, the Direct Object Restriction is clearly violated in Mandarin (cf. Li, 1999). Consider the following literal resultative verb compounds in Chinese:

- (29) a. *Zhang₁san₁ chi₁ bao₃ le₅*
 Zhangsan eat full LE
 ‘Zhangsan ate himself full.’
- b. *Li₃si₄ pao₃ lei₄ le₅*
 Lisi run tired LE
 ‘Lisi ran himself exhausted.’
- c. *wo₃ xiao₄ si₃ le₅*
 I laugh dead LE
 ‘I laughed myself to death.’

Clearly, the result (i.e., V_2) is predicated of the subject. It is Zhangsan that becomes full as a result of the eating in (29a); Lisi that becomes tired as a result of the running in (29b); and the speaker that metaphorically dies as a result of the laughing (29c). I refer to these cases as subject-control RVCs. Note these resultative verb compounds are generally acceptable in the *de* construction:

- (30) a. *Zhang₁san₁ chi₁ de₅ bao₃ le₅*
 Zhangsan eat DE full LE
 ‘Zhangsan ate himself full.’
- b. *Li₃si₄ pao₃ de₅ lei₄ le₅*
 Lisi run DE tired LE
 ‘Lisi ran himself exhausted.’
- c. **wo₃ xiao₄ de₅ si₃ le₅*
 I laugh DE dead LE
 ‘I laughed myself to death.’

Sentence (30c) is ungrammatical because the death cannot be interpreted metaphorically. This points to an interesting difference between *de* resultatives and normal verbal compounds: it appears that the latter can acquire idiosyncratic meaning, e.g., an idiomatic or metaphoric interpretation, which is unavailable in the former. This issue will be taken up in Section 3.8.

While nearly all subject-control resultative verb compounds are intransitive, there are instances of transitive sentences where the result is predicated of the subject:

- (31) a. *Zhang₁san₁ chi₁ bao₃ le₅ fan₄*
 Zhangsan eat full LE meal
 ‘Zhangsan got full from eating the meal.’
- b. *Li₃si₄ he₁ zhui₄ le₅ jiu₃*
 Lisi drink drunk LE wine
 ‘Lisi got drunk from drinking the wine.’

These examples have bearing on the issue of control and the validity of the Minimum Distance Principle (Rosenbaum, 1967), to be discussed in Section 3.6. It is important to note, however, that the direct objects in example (31) must be non-referential; the event denoted by V_1 in both cases is best analyzed as generic, i.e., the activity of “meal-eating” or “wine-drinking”. The sentences become ungrammatical with referential objects:

- (32) a. **Zhang₁ san₁ chi₁ bao₃ le₅ san₁/na₄/na₃ wan₃ fan₄*
 Zhangsan eat full LE three/that/which bowl rice
 intended: ‘Zhangsan got full from eating three/that/which bowl(s) of rice.’
- b. **Li₃ si₄ he₁ zhu₁ le₅ liang₃/na₄/na₃ bei₁ jiu₃*
 Lisi drink drunk LE two/that/which glass wine
 intended: ‘Lisi got drunk from drinking two/that/which glass(es) of wine.’

The situation is, in fact, even more complex; there are examples of transitive RVCs in Mandarin where the sentence is ambiguous between subject and object control. In other words, the result can be interpreted as either being predicated of the subject or the direct object. Consider the following example:

- (33) *Zhang₁ san₁ qi₂ lei₄ le₅ ma₃*
 Zhangsan ride tired LE horse
 ‘Zhangsan rode the horse, and ...’
- i. ‘the horse got tired as a result.’
 ii. ‘Zhangsan got tired as a result.’

In (33), two readings are available: one where Zhangsan becomes tired, and another where the horse becomes tired. Mandarin speakers are forced to employ context in determining the correct interpretation. However, it is important to note that, just like the examples shown in (31), the subject-control reading is only available with non-referential objects:

- (34) *Zhang₁ san₁ qi₂ lei₄ le₅ liang₃/na₄/na₃ pi₁ ma₃*
 Zhangsan ride tired LE two/that/which CL horse
 ‘Zhangsan rode the horse, and ...’
- i. ‘the horse got tired as a result.’
 ii. *‘Zhangsan got tired as a result.’

Given these facts, it seems clear that in subject-control resultatives with direct objects, the direct object is not an argument of the entire compound, but rather forms a complex predicate with the activity verb. The best evidence for this is the non-referential requirement on these objects: referential objects force an object-control interpretation, which may lead to a crash at LF in the case of the examples in (32). Thus, the examples in (31) should be paraphrased as:

- (35) a. Zhangsan engaged in the activity of meal-eating and became full as a result.
 b. Zhangsan engaged in the activity of wine-drinking and became drunk as a result.

Correspondingly, the two different readings of (33) are paraphrased in (36). In Section 3.4, I will demonstrate how these different readings can be syntactically captured.

- (36) a. Zhangsan engaged in the activity of riding which acted on and affected the horse, and the horse became tired as a result.
 b. Zhangsan engaged in the activity of horse-riding, and he became tired as a result.

In summary, the answer to the question “What is the result predicated of?” depends on the language: in Mandarin, the result can be predicated of either the subject or the direct object unambiguously. I call these cases *subject control* and *object control*, respectively. Certain Mandarin RVCs, however, display the interesting behavior where both a subject control and object control reading is available (with a non-referential object). Turning to English, however, it remains an open research question whether or not the Direct Object Restriction is a valid empirical generalization. Although it has been abandoned by some linguists, I have presented evidence that this may be premature.

3.3.2 Which verb is the direct object an argument of?

One important dimension of variation observed in resultative constructions concerns the post-verbal DP (if there is one): which verb is it an argument of, and is it selected for (by the first verb)? In principle, there are only two possibilities: the object is either subcategorized for by the first verb, or it is not. Examples from English are shown below:

- (37) a. John hammered the metal flat.
 b. They drank the pub dry.
 c. Mary laughed herself silly.

In (37a), *the metal* is a semantic argument of the matrix verb *hammer*, whereas in (37b) and (37c), *the pub* and *herself* are not. For resultatives whose objects are selected by the matrix verb, the corresponding simple sentences without the result phrase are grammatical:

- (38) a. John hammered the metal.
 b. *They drank the pub.
 c. *Mary laughed herself.

Resultatives whose objects are unselected for by the matrix verb are sometimes called ECM resultatives. They pattern with a very broad class of constructions in English, namely those involving exceptional case-marking verbs. Thus, it is believed that these resultatives should be analyzed in the same fashion as the following sentences; see Simpson (1983) and Carrier and Randall (1992) for further discussions:

- (39) a. They consider Mary a good candidate.
 b. John believes her to be intelligent

Of English resultatives with unselected objects, the type exemplified by (37c) is often called the “fake reflexive” resultative. Resultatives in English based on unergatives cannot directly have the result phrase directly predicated of the subject (one type of evidence in support of the DOR); instead, this relationship must be mediated by a reflexive pronoun that anaphorically binds the subject. Resultatives involving unergatives are ungrammatical without this fake reflexive:

- (40) a. Mary laughed *(herself) silly.
 b. John ran *(himself) exhausted.

Since the Direct Object Restriction does not appear to be a valid generalization for Mandarin (i.e., the result can be directly predicated of the subject), “fake reflexive” pronouns are not necessary in Chinese. In fact, adding a reflexive pronoun often gives rise to a subtle change in meaning, and sometimes leads to an ungrammatical sentence:

- (41) a. **Zhang₁ san₁ chi₁ bao₃ le₅ zi₄ji₃*
 Zhangsan eat full LE himself
 intended: ‘Zhangsan ate himself full.’
 b. *Li₃ si₄ pao₃ lei₄ le₅ zi₄ji₃*
 Lisi run tired LE himself
 ‘Lisi ran himself exhausted.’
 c. *wo₃ xiao₄ si₃ le₅ zi₄ji₃*
 I laugh dead LE myself
 ‘I laughed myself to death.’

While (41a) is ungrammatical, (41b) and (41c) appear to convey a sense of extra effort, or extra affectedness of the subject. One reading might be that the subject doesn’t really have control of himself, and is almost manipulating his body like a puppet. For example, consider scenario of Lisi, after a bad breakup, runs and runs to forget his troubles. In that case, (41b) would be a very adept description of the situation.

Finally, the situation with a reflexive pronoun in the *de* construction is quite complex:

- (42) a. *??Zhang₁san₁ chi₁ de₅ zi₄ji₃ bao₃ le₅*
 Zhangsan eat DE himself full LE
 intended: ‘Zhangsan ate himself full.’
- b. *Li₃si₄ pao₃ de₅ zi₄ji₃ lei₄ le₅*
 Lisi run DE himself tired LE
 ‘Lisi ran himself exhausted.’
- c. **wo₃ xiao₄ de₅ zi₄ji₃ si₃ le₅*
 I laugh DE myself dead LE
 ‘I laughed myself to death.’

Sentence (42a) sounds unnatural, (42c) is ungrammatical because the literal death reading is unavailable, but (42b) sounds fine. Once again, a possible reading is that the subject is manipulating himself involuntarily.

Mandarin resultative verb compounds with reflexive pronouns as a special case aside, there are two possibilities for the direct object: it could be a semantic argument of V_1 , or it can bear no semantic relationship to it (I refer to these two cases as *selected* and *non-selected*, respectively). The two possibilities are shown below:

(43) Selected, object-control RVC

- a. *Zhang₁san₁ kan₃ dao₃ le₅ shu₄*
 Zhangsan chop fall LE tree
 ‘Zhangsan chopped the tree down.’
- b. *Li₃si₄ ca₁ gan₁ le₅ zhou₁zi₅*
 Lisi wipe dry LE table
 ‘Lisi wiped the table dry.’

(44) Non-selected, object-control RVC

- a. *Zhang₁san₁ xiao₄ tung₄ le₅ du₄zi₅*
 Zhangsan laugh hurt LE stomach
 ‘Zhangsan laughed so hard his stomach hurt.’
- b. *Li₃si₄ ku₁ shi₁ le₅ shou₃pa₄*
 Lisi cry wet LE handkerchief
 ‘Lisi cried his handkerchief wet.’

Since subject-control RVCs, for the most part, are all intransitive, the selected/non-selected distinction mostly applies to object-control resultative verb compounds. In each of the examples in (43), the direct object of the entire compound is also the semantic argument of V_1 , whereas in each of the examples in (44), the direct object bears no semantic relationship to V_1 .⁵ As in English, the simple non-resultative counterparts of the sentences in (43) are grammatical, while the simple non-resultative counterparts of the sentences in (44) are not:

⁵As I will show later, object-control, non-selected RVCs do not involve control at all; I will, however, continue employing this terminology for the sake of consistency.

- (45) a. *Zhang₁san₁ kan₃ le₅ shu₄*
 Zhangsan chop LE tree
 ‘Zhangsan chopped the tree.’
- b. *Li₃si₄ ca₁ le₅ zhou₁zi₅*
 Lisi wipe LE table
 ‘Lisi wiped the table.’
- (46) a. **Zhang₁san₁ xiao₄ le₅ du₄zi₅*
 Zhangsan laugh LE stomach
 intended: ‘Zhangsan laughed his stomach.’
- b. **Li₃si₄ ku₁ le₅ shou₃pa₄*
 Lisi cry LE handkerchief
 intended: ‘Lisi cried his handkerchief.’

In the previous two sections, I have discussed variations involving the internal arguments of Mandarin resultative verb compounds. The next section will focus on variations involving the external argument.

3.3.3 Causatives and External Arguments

Mandarin RVCs present a number of interesting situations involving the realization of the external argument. In typical cases, the external argument is the subject (i.e., agent) of V_1 . However, the external argument can remain unrealized in a productive alternation:

- (47) a. *Zhang₁san₁ kan₃ dao₃ le₅ shu₄*
 Zhangsan chop fall LE tree
 ‘Zhangsan chopped the tree down.’
- b. *shu₄ kan₃ dao₃ le₅*
 tree chop fall LE
 ‘The tree got chopped down.’
- (48) a. *Li₃si₄ ku₁ shi₁ le₅ shou₃pa₄*
 Lisi cry wet LE handkerchief
 ‘Lisi cried his handkerchief wet.’
- b. *shou₃pa₄ ku₁ shi₁ le₅*
 handkerchief cry wet LE
 ‘The handkerchief got wet from crying.’

I refer to these constructions as *reduced resultative verb compounds*. Lacking the morpheme *bei*, these Mandarin sentences are not passives; the most natural translation for them however, employs a *get* passive in English. I will defer a detailed syntactic analysis of these constructions until Section 3.7. The primary purpose of

the present discussion is to enumerate all the facts that a theory of resultative verb compounds must account for.

In Mandarin, the subject of the entire verbal compound may not bear any semantic relationship to either V_1 . A special case of this is a productive alternation involving unalienable possessions (one's hands, eyes, throat, etc.). Compare the typical unselected, object-control compound in (49a) with (49b), a synonymous alternate form (which sounds strange in the *de* construction).

- (49) a. *Zhang₁san₁ xiao₄ tung₄ le₅ du₄zi₅*
 Zhangsan laugh hurt LE stomach
 'Zhangsan laughed so hard that his stomach hurt.'
- b. *Zhang₁san₁ de₅ du₄zi₅ xiao₄ tung₄ le₅*
 Zhangsan DE stomach laugh hurt LE
 'Zhangsan's stomach hurt from laughing so hard.'
- c. *??Zhang₁san₁ de₅ du₄zi₅ xiao₄ de₅ tung₄ le₅*
 Zhangsan DE stomach laugh DE hurt LE
 'Zhangsan's stomach hurt from laughing so hard.'

Critically, the subject of the entire verbal compound is not an argument of V_1 : the stomach is not doing the laughing, but rather is involved in the result of the laughing event.

Other examples of RVCs in Mandarin where the external argument is not a semantic argument of either V_1 or V_2 are shown below:

- (50) a. *na₄ ping₂ jiu₃ he₁ zhui₄ le₅ Zhang₁san₁*
 that bottle wine drink drunk LE Zhangsan
 'That bottle of wine got Zhangsan drunk.'
- b. *na₄ jian₄ shi₄ xiao₄ si₃ le₅ wo₃*
 that CL matter laugh dead LE I
 'That matter laughed me to death.'

In these cases, the external argument is interpreted as a non-agentive cause. Similar sentences are available with the *de* construction also:

- (51) a. *zhe₄ feng₁ xin₄ xie₃ de₅ wo₃ (de₅) shou₃ suan₁ le₅*
 this CL matter write DE I DE hand sore LE
 'My hand got sore from writing this letter.'
- b. *na₄ dui₁ gong₁ke₄ mang₂ de₅ Zhang₁san₁ chuan₃bu₂guo₄qi₄*
 that pile homework busy DE Zhangsan breathless
 'Zhangsan is so busy from that pile of homework that he can't catch his breath.'

In summary, the external argument of Mandarin resultative verb compounds can vary in a variety of interesting ways. The external argument can simply be omitted, in what appears to be a productive process, forming what I call reduced RVCs. The external argument can be an inalienable possession of an implicit agent, or it can be a totally unrelated cause that bears no direct semantic relation to V_1 or V_2 .

3.4 The Basic Syntax of Verbal Compounds

Having explored the typology of Mandarin resultative verb compounds, I will proceed to provide a syntactic analysis that captures the dimensions of variation outlined in the last section. As a starting point, consider an inchoative sentence (52), whose structure is shown in (53). This analysis was discussed in the previous chapter.

- (52) *shu₄ dao₃ le₅*
 tree fall LE
 ‘The tree fell.’

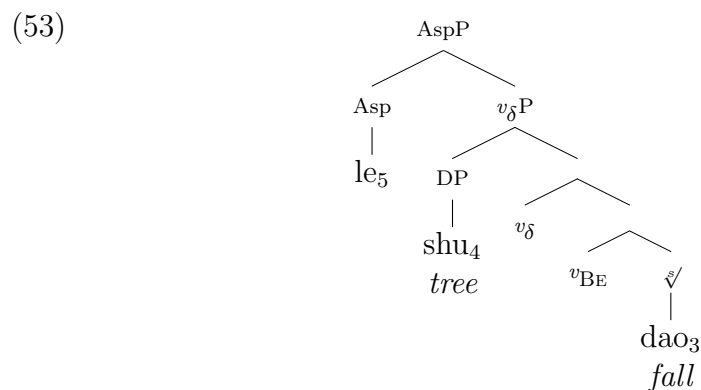

Now consider a resultative verb compound built on top of (52), representing a transitive accomplishment:

- (54) *Zhang₁ san₁ kan₃ dao₃ le₅ shu₄*
 Zhangsan chop fall LE tree
 ‘Zhangsan chopped the tree down.’

It is important to note that the subject of the inchoative sentence (52) bears the same semantic relation to *dao₃* ‘fall’ as the object of the transitive sentence (54). This, naturally, should be reflected in the syntax. As a side note, this phenomenon is not an issue with English resultatives because the result phrase is either an adjective or a prepositional phrase; it cannot serve as the main predicate of a corresponding simple sentence.

Following the tradition of analyzing accomplishments as bi-eventive, the syntactic structure of (54) might be the following (omitting the aspectual projection):

(55)

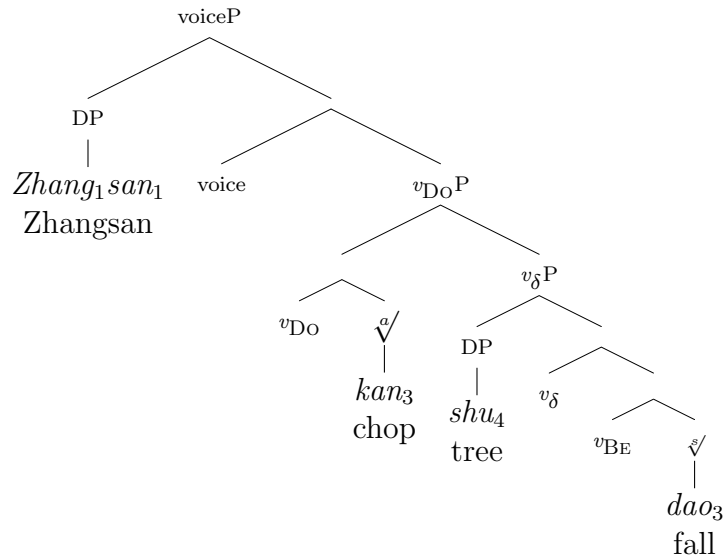

The intuition behind this analysis is straightforward: on top of the inchoative core, a Mandarin speaker simply adds an additional causing activity, appropriately modified by an activity verbal root. Head movement of the lower stative root up to the higher activity root would derive the correct surface order.

The biggest problem with this analysis, however, is that no semantic relationship is represented between the tree (undergoer of the change of state) and the chopping activity (which directly involves the tree). If the above syntactic structure is correct, an object-control, non-selected resultative verb compound, such as the following, should be analyzed in the same way.

- (56) *Li₃si₄ ku₁ shi₁ le₅ shou₃pa₄*
 Lisi cry wet _{LE} handkerchief
 ‘Lisi cried his handkerchief wet.’

If both selected and non-selected (object-control) RVCs share the same structure, then what gives rise to the different interpretations? In (54) the result is brought about by Zhangsan chopping the tree, whereas in (56) the handkerchief is not an argument of the crying. A similar problem is faced by the small clause analysis of resultative espoused by Kayne (1985), Van Voorst (1986), and Hoekstra (1988), and Sybesma (1999); see Carrier and Randall (1992) for discussions. The solution lies in pragmatics, argues Kayne: the interpretation of selected and non-selected RVCs involve real-world knowledge. In order for the tree to fall, he would claim, a speaker must reconstruct a scenario in which the tree is being chopped, thereby establishing the correct semantic relationship between the chopping and the tree. The example in (56) can be explained in a similar way: from extra-linguistic knowledge, a listener knows that one doesn’t “cry a handkerchief”. Hoekstra (1988) argues for the same point, calling this phenomenon *shadow interpretation*.

The biggest problem with this pragmatic explanation based on real-world knowledge is overgeneration: it predicts a number of resultative verb compounds that are

impossible, and it predicts a number of different readings that simply do not exist. For example, consider the scenario where Zhangsan chops a tree, which falls over and knocks a second tree down. Sentence (54) cannot be used to describe this situation (referring to the fall of the second tree), although it is not outside the realm of possibility.

If the connection between the causing event and the result is simply a matter of real-world knowledge, then the following sentence should be perfectly grammatical:

- (57) *??Zhang₁san₁ kan₃ diao₄ le₅ shu₄ye₄*
 Zhangsan chop drop LE leaf
 ‘Zhangsan’s chopping caused the leaves to fall off.’

The sentence is odd sounding to native speakers, even though a corresponding real-world scenario is very plausible: Zhangsan’s chopping of the tree trunk shook all the leaves off the tree (without necessarily knocking the tree over). This interpretation involving indirect causation, however, is not available. The only felicitous reading is the literal interpretation of the resultative verb compound: Zhangsan individually chops each leaf off the tree. More attention will be devoted to this issue in Section 3.8.

Problems associated with a uniform treatment of both selected and non-selected RVCs also means that lexical semantic representations proposed by Dowty (58) and Rappaport Hovav and Levin (59) are, at best, incomplete:

- (58) [[DO(*Zhangsan*, chop)] CAUSE [BECOME [fallen(*the tree*)]]]
 (59) [[*Zhangsan* ACT_{<CHOP>}] CAUSE [BECOME [*tree* <FALLEN>]]]

These representations also do not capture the semantic relationship between the chopping activity and the tree. Although one could simply add an extra argument in the causing subevent, this fix merely pushes the problem off to another component of the theory. How is it that the tree occurs twice in the lexical semantic representation, but only once in the surface form? Placing an additional argument in the event representation will most likely come at the cost of increased complexity in the linking rules to specify how the argument is “shared” by the two subevents.

Another problem with a uniform analysis of selected and non-selected RVCs is that the structure of V_1 in the compound differs from that of the same verb in isolation (i.e., in simple sentences). Levin and Rappaport Hovav (1995:41–55), citing syntactic evidence from Carrier and Randall (1992), meticulously demonstrate that this cannot be the case. They argue, at least for English, that the lexical representation of the verb in the resultative construction does *not* differ from that of the same verb in isolation. Furthermore, in selected resultatives, the direct object bears the same structural relationship to the main verb in the resultative construction as it does in the simple sentence. Since I have nothing to add to Levin and Rappaport Hovav’s arguments, except to extend the generalization to Mandarin, their evidence will not be repeated here.

Consider the sentence (60), whose possible syntactic structures are shown in (61). Recall from Section 1.2.1 that a transitive activity verb has two different interpretations, depending on whether or not the object is interpreted as an affected argument.

- (60) *Zhang₁ san₁ kan₃ le₅ shu₄*
 Zhangsan chop LE tree
 ‘Zhangsan chopped (at) the tree.’

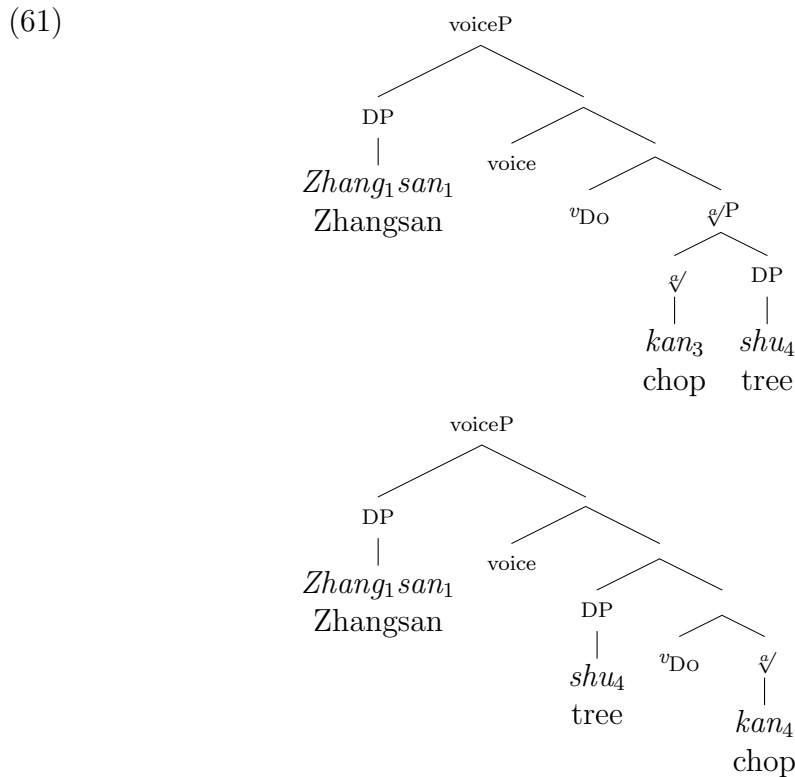

The verbalizing head v_{Do} licenses an activity and is modified by the activity root v/kan_3 ‘chop’. In the case where the DP shu_4 ‘tree’ is idiosyncratically licensed by the verbal root, the entire event is interpreted as “the activity of tree-chopping” (the top structure). In the case where the DP is structurally licensed by v_{Do} , the object is interpreted as an affected argument, i.e., “the activity of chopping that acts on and causes an affect on the tree”. As discussed previously, the *voice* head projects the external argument, which comes to be interpreted as the agent. Comparing (61) to the structures in (55), we see that Levin and Rappaport Hovav’s generalization is violated.

In summary, we have two competing constraints that need to be satisfied. On the one hand, Levin and Rappaport Hovav argue that there is nothing particularly special about the direct object in a selected resultative (compared to a simple transitive sentence). On the other hand, I have presented evidence from Mandarin that there is nothing particularly special about V_1 in the verbal compound: the post-verbal object must maintain the same relationship to V_2 as it does in an intransitive sentence. Given these requirements, it appears that the most plausible analysis of (55) is the following:

(62)

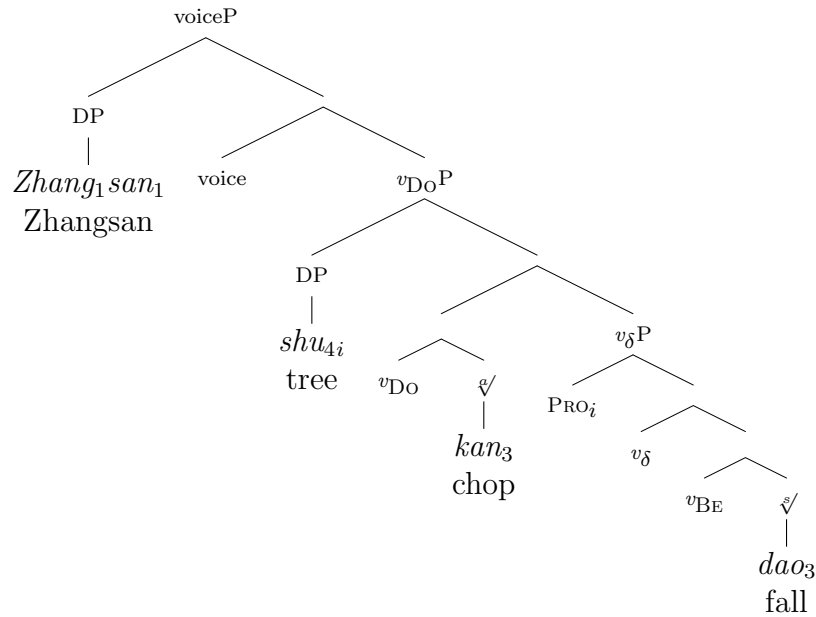

Since the direct object in resultative constructions (the object-control case) is necessarily affected by the event, it is unlikely that the object is idiosyncratically licensed by the verbal root. This rules out the basic configuration on the top in (61). Under my analysis, the argument structure of $\sqrt{\text{chop}}$ and $\sqrt{\text{fall}}$ are the same as in their respective simple sentences. The primary difference, obviously, is that one event is now causally related to the other by the head-complement relation between v_{Do} and v_{δ} ; refer back to Section 1.2.2 for a discussion of causation. The “sharing” of the DP *shu*₄ ‘tree’ is mediated by PRO in the specifier of v_{δ} (the “subject” position), bound to the DP structurally licensed by the activity root *kan*₃ ‘chop’. In principle, it does not matter whether the subject of v_{δ} is PRO or pro. Huang (1998) convincingly argues that the distinction is blurred in Mandarin, and that the properties of PRO and pro overlap. A more detailed discussion of control is saved for Section 3.6.

The sentence in (63), a non-selected, object-control resultative verb compound repeated from (56), has the structure in (64).

- (63) *Li*₃*si*₄ *ku*₁ *shi*₁ *le*₅ *shou*₃*pa*₄
 Lisi cry wet _{LE} handkerchief
 ‘Lisi cried his handkerchief wet.’

(64)

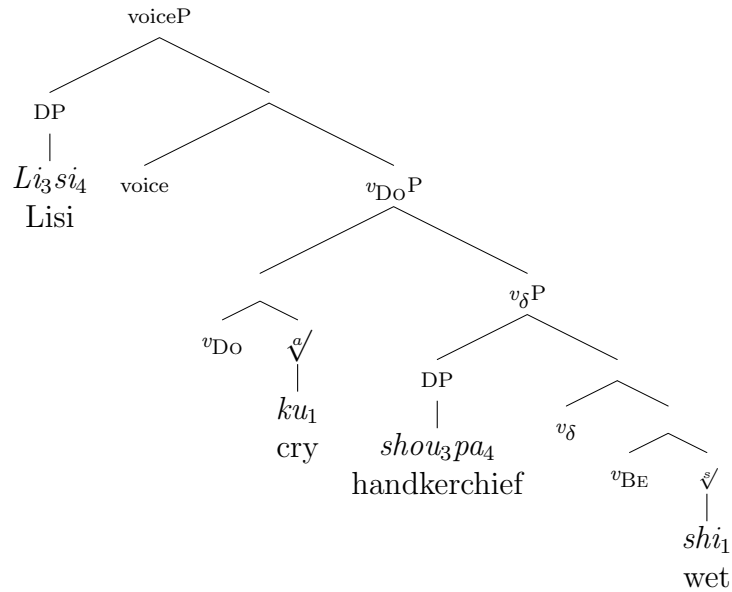

This structure correctly captures the lack of a semantic relationship between the handkerchief and the activity root $\sqrt{ku_1}$ ‘cry’, i.e., the direct object of the entire verbal compound is not selected for by V_1 . Note that the handkerchief is in the specifier of v_δ , not v_{Do} . In my framework, argument sharing between the two verbs is implemented via control; since there is no argument sharing in the case of non-selected resultatives, there is no control relationship (the classification of the above structure as an object-control, non-selected RVC is not technically accurate; for consistency, however, I will continue employing this terminology).

Finally, a resultative verb compound in which V_2 is predicated of the subject, i.e., a subject-control RVC such as (65), has the structure shown in (66). The only difference between this type of resultative and the ones typified by (63) is the PRO in the specifier position of v_δ , which is co-indexed with the external argument.

- (65) wo_3 $xiao_4$ si_3 le_5
 I laugh dead LE
 ‘I laughed myself to death.’

(66)

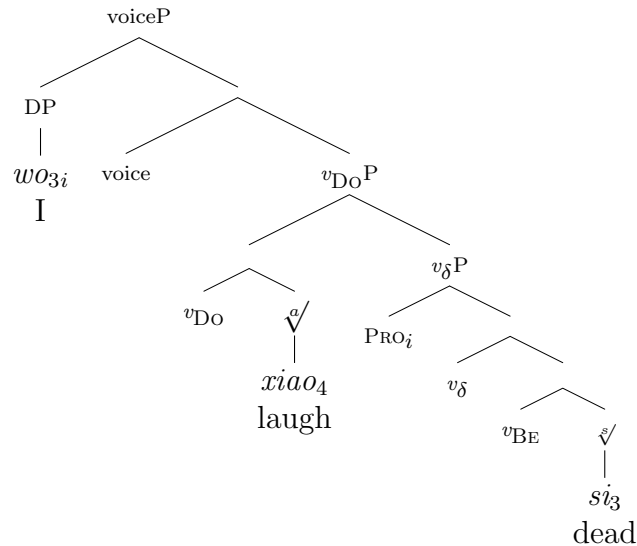

What are restrictions on the antecedent of the PRO? Does the Minimum Distance Principle (Rosenbaum, 1967) apply in Mandarin, or do more complex semantic and pragmatic factors play in the determination of an antecedent? Let us consider the two cases where the MDP appears to be violated:

(67) *Zhang₁ san₁ chi₁ bao₃ le₅ fan₄*
Zhangsan eat full LE meal
'Zhangsan got full from eating the meal.'

(68) *Zhang₁ san₁ qi₂ lei₄ le₅ ma₃*
Zhangsan ride tired LE horse
'Zhangsan rode the horse, and ...'

- i. 'the horse got tired as a result.'
- ii. 'Zhangsan got tired as a result.'

On the surface, the above examples appear to violate the Minimum Distance Principle, because the direct object is structurally closer to the resulting predicate. It seems that the PRO "skips" over the direct object in search of a controller. However, I have shown in Section 3.3.1 that these objects must be non-referential. Syntactically, these objects must be idiosyncratically licensed, not affect arguments structurally licensed by v_{Do} . The correct structure for (67) is the following:

(69)

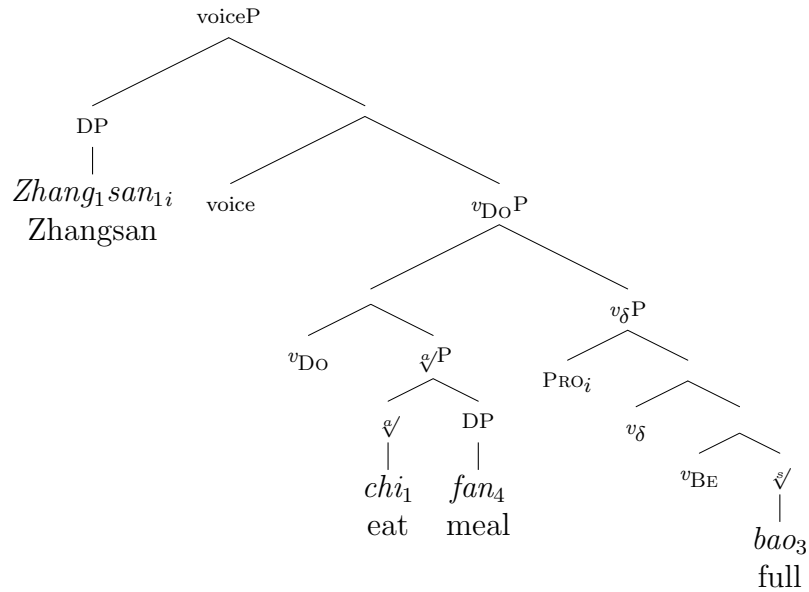

The node immediately dominating *v_{Do}* and the root phrase is interpreted as “the activity of meal-eating”. Since *fan₄* ‘meal’ does not c-command *PRO*, it cannot be the controller; the only other available option is the external argument, and hence the sentence must be understood as a subject-control resultative.

Why can’t the meal be structurally licensed by *v_{Do}*, i.e., why can’t it be interpreted as an affect argument? The situation would correspond to the following structure:

(70) *

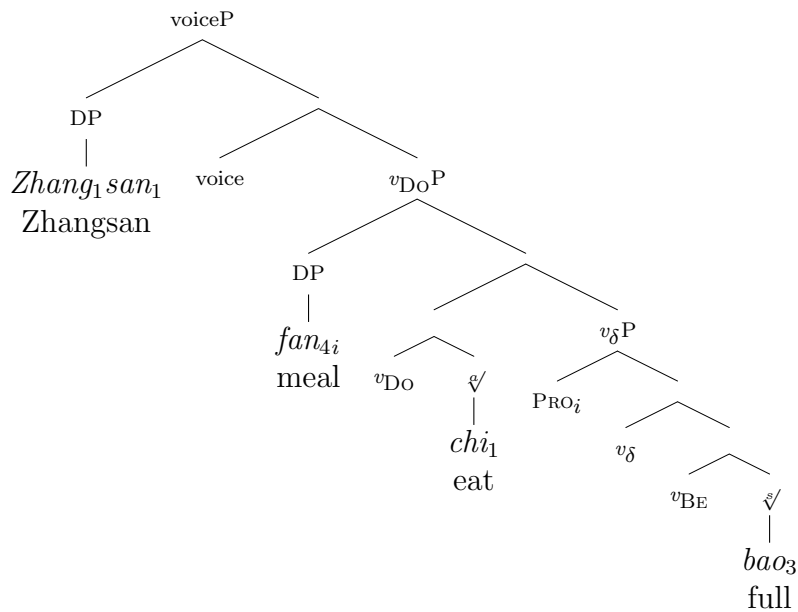

Given that *fan₄* ‘meal’ c-commands the *PRO* and is the closer DP, it must be interpreted as the controller. Such a reading, however, makes no sense: the meal cannot become full as a result of the eating. This derivation crashes at LF, which accounts for the unavailability of the object-control interpretation for sentence (67).

What about the sentence in (68)? The same account can readily explain the two different readings:

(71) subject-control interpretation, Zhangsan becomes tired:

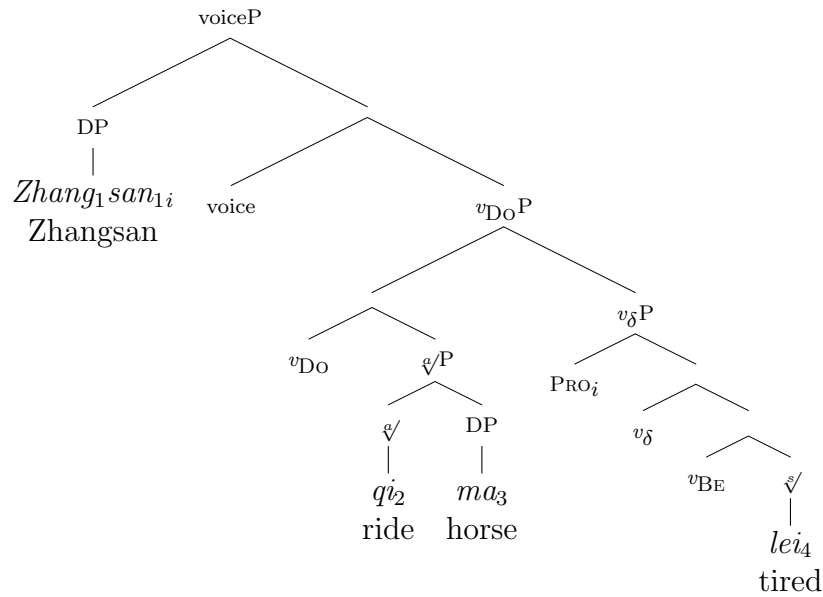

(72) object-control interpretation, the horse becomes tired:

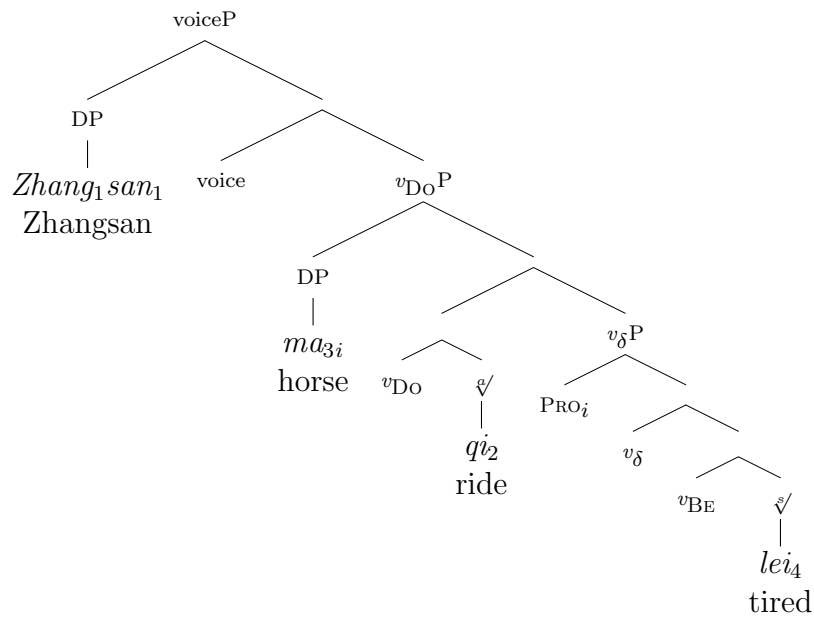

In other words, semantic ambiguity arises from a syntactic ambiguity. If the direct object is viewed as an idiosyncratically-licensed argument, then it is too deeply embedded to c-command the *PRO*; hence, the controller must be the external argument, and the entire sentence must be interpreted as subject control. If the direct object is viewed as an affected argument, which places it in the specifier position of *v_{Do}*, an object-control reading arises because the direct object c-commands the *PRO* and is the closest DP.

To derive the surface word order of the sentence, the lowest verbalizing head (*v_{BE}*) undergoes successive movement, up through *v_δ*, *v_{Do}*, and *voice* (beyond the domain

of the verb phrase, movement continues up to Aspect). The verbal roots themselves are pied-piped along. This process is illustrated below:

(73)

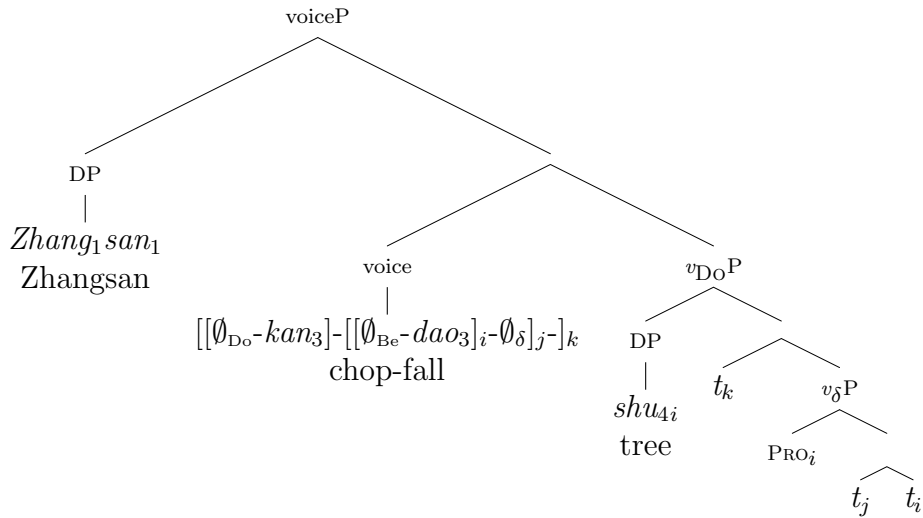

An advantage of this analysis is a straightforward account of the *ba* construction. In the Mandarin *ba* construction with a resultative verb compound, the word order is [DP₁ *ba* DP₂ V₁ V₂], where the DP immediately following *ba* must be an affected argument. Thus, the following sentence is unambiguous:

(74) *Zhangsan ba ma qi lei le*
 Zhangsan BA horse ride tired LE
 ‘Zhangsan rode the horse, and ...’

- i. ‘the horse got tired as a result.’
- ii. *‘Zhangsan got tired as a result.’

The particle *ba* can simply be viewed as the overt realization of *voice*. In the absence of verb movement to the *voice* position, the functional head must be overtly realized. An affected argument is necessary to license the *ba* construction, which is satisfied by the argument in the specifier of *v*_{Do}.⁶ Since in the subject-control interpretation, corresponding to the structure shown in (71), the horse is not an affected argument, the *ba* form is not available, hence the impossibility of reading (74ii).

Here I have presented a brief sketch of what a theory of the Mandarin *ba* construction would look like in my framework. A more detailed consideration of all possible variations with *ba* is beyond the scope of this work; for a broader overview, see, for example, Liu (1997).

By hypothesis, resultatives in English share the same basic underlying structure as Mandarin RVCs. Many differences between the two languages can be attributed

⁶In the example of the structure shown in (64), the handkerchief first moves to [Spec, *v*_{Do}] before *ba* is licensed; it is, after all, an affected argument.

to the categorial status of the result phrase (verb phrase in Mandarin, adjective or prepositional phrase in English). A typical object-control, selected RVC (75a) has the syntactic structure shown in (76), and a typical object-control, non-selected RVC (75b) has the syntactic structure shown in (77).

- (75) a. Mary hammered the metal flat.
 b. John drank the pub dry.

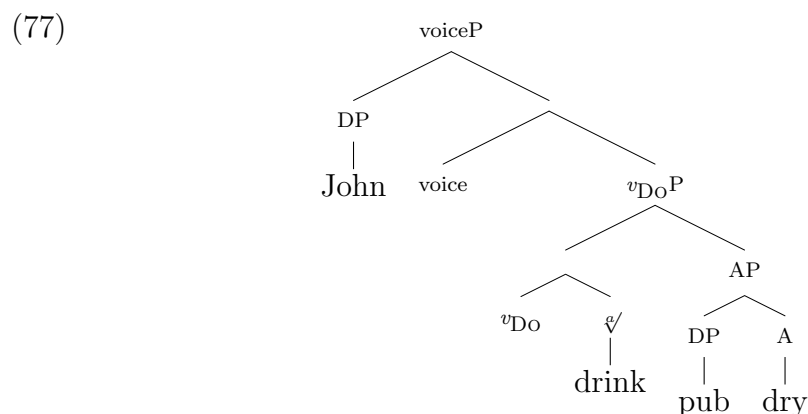
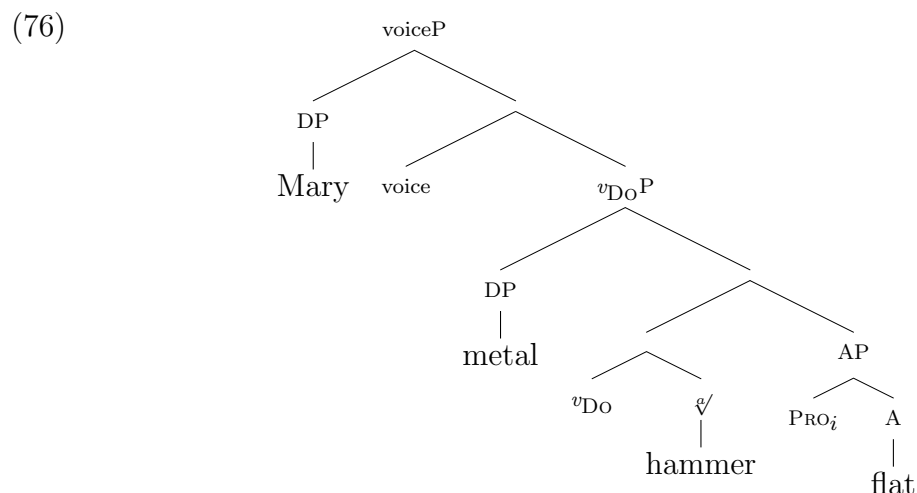

English appears to forbid idiosyncratically-licensed DPs in resultative constructions, such as those paralleling the structure shown in (71). As a result, the following sentences are ungrammatical in English under a subject-control interpretation:

- (78) a. John drank the beer drunk. (depictive reading only)
 b. John wrote the letter exhausted. (depictive reading only)

This concludes my basic syntactic analysis of Mandarin and English resultatives. I have shown how variations in the semantics of resultative constructions can be neatly captured in my syntactic framework. This basic account will be refined and elaborated on over the next few sections.

3.5 The Syntax of Spurious Compounds

As previously discussed, there exist verbal compounds in Mandarin that are not resultative in nature. The most common type of such compounds consist of two stative verbs. Some examples are shown below, repeated from (18):

- (79) a. *Zhang₁san₁ zhui₄ dao₃ le₅*
 Zhangsan drunk fall LE
 ‘Zhangsan got so drunk he fell.’
- b. *Li₃si₄ lei₄ hui₄ le₅*
 Lisi tired bad LE
 ‘Lisi got really tired.’
- c. *lao₃hu₃ si₃ diao₄ le₅*
 tiger die drop LE
 ‘The tired died.’

In these types of verbal compounds, V_1 must denote a literal result, but no semantic restriction exists for V_2 . Let us consider (79a) in a bit more detail. It is easy to confirm that *zhui₄* ‘drunk’ and *dao₃* ‘fall’ are both indeed states. The contradiction test renders their stative status apparent:

- (80) a. *#Zhang₁san₁ zhui₄ le₅, ke₃shi₄ ta₁ mei₂ zhui₄*
 Zhangsan drunk LE but he not drunk
 intended: ‘Zhangsan got drunk, but he wasn’t drunk.’
- b. *#shu₄ dao₃ le₅, ke₃shi₄ mei₂ dao₃*
 tree fall LE but not fall
 intended: ‘The tree fell, but it didn’t really fall.’

In a double-state compound such as *zhui₄ dao₃* ‘drunk fall’, it appears that *dao₃* ‘fall’ is serving as a state modifier of *zhui₄* ‘drunk’, further elaborating on the meaning inherent in “drunkenness”. For example, it is possible to be drunk without falling over, and *zhui₄ dao₃* can be viewed as a particular type of *zhui₄*. However, it is important to note that V_2 does not need to be interpreted literally; in (79a), Zhangsan does not have to fall as a result of being drunk in order for the sentence to be felicitous; the closest meaning in English is “a stumbling drunk”.

Levin and Rappaport Hovav (1995:59) employ the same line of reasoning to explain sentences such as “John broke the nut open” and other resultatives based on unaccusative verbs such as the following, repeated from (19):

- (81) a. The pond froze solid.
 b. The gate opened wide.
 c. The vase broke into bits.

It is possible for a pond to freeze without being solid. A thin layer of ice could have just formed over the surface; note that “solid” is being used here in the sense of “durable”, not as a phase of matter (vs. liquid or gas). For (81b) and (81c), the situation is exactly the same: the result phrase further specifies the end state already encoded by the change of state predicate.

An alternative explanation for these English constructions⁷ is that the unaccusative verbs undergo a meaning shift so that they no longer encode their end state; as an example, *freeze* would mean “going towards a state of being frozen” (without necessarily arriving at the end point). The result phrase would then serve as the delimiter of the sentence by encoding the final end state. Such an account should, however, be ruled out because it predicts interpretations that do not exist. For example, if it were possible for an unaccusative to undergo such a meaning shift, then it should pass the contradiction test. In English, the meaning of a verb like *freeze* is such that something cannot freeze without being frozen.

The interpretation of many double-state verbal compounds in Mandarin is entirely idiomatic, as in the case of (79b) and (79c). For example, (79c) is akin to the English idiom chunk “drop dead”; in both cases, there is no dropping of any sort involved.

For these reasons, double-state verb compounds in Mandarin cannot be considered true resultatives. They do not describe a complex bi-eventive structure consisting of a causing activity and a result state. These verbal combinations behave exactly like unaccusative verbs, except that in place of a single stative root, there is a complex head consisting of two stative roots. The structure of a double-state compound in Mandarin is shown in (82). Syntactically, I believe that V_2 is adjoined to V_1 to form a complex head. There is, however, no direct evidence to rule out a small clause analysis as an alternative. The corresponding structure in English is shown in (83).

(82)

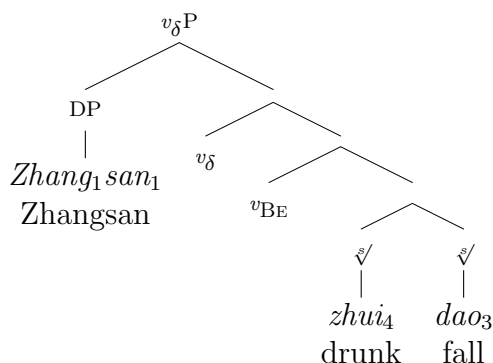

⁷pointed out by Alec Marantz (p.c.)

(83)

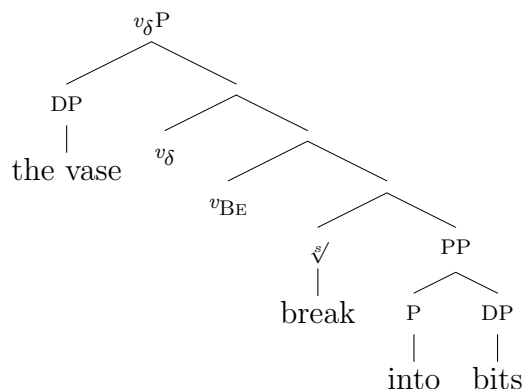

Although double-state compounds are mostly idiomatic, semi-productive processes govern the formation of certain combinations. A class of examples involves si_3 ‘die’ as V_2 . The verb can be appended to many states to achieve an intensification effect: $lei_4 si_3$ ‘tired die’, $mang_2 si_3$ ‘busy die’, $le_4 si_3$ ‘glad die’, $qi_4 si_3$ ‘angry die’, etc. This effect also accounts for the existence of many three verb RVCs in Mandarin. Note however, that when si_3 ‘die’ occurs with an activity, the result is a true resultative verb compound (albeit one where the result is interpreted metaphorically).

A double-state compound has the ability to undergo causativization without needing to undergo further compounding, i.e., the higher causing eventuality does not need to be modified (and cannot be modified) by an verbal root:

- (84) a. $na_4 ping_2 jiu_3 zhui_4 dao_3 le_5 Zhang_1 san_1$
 that bottle wine drunk fall _{LE} Zhangsan
 ‘The bottle of wine got Zhangsan so drunk he fell over.’
- b. $Li_3 si_4 zhui_4 dao_3 le_5 Zhang_1 san_1$
 Lisi drunk fall _{LE} Zhangsan
 ‘Lisi got Zhangsan so drunk he fell over.’

The causing eventuality can either be a state, as in some property of the bottle of wine (84a), or an activity, as in something that Lisi did (84b). The relevant fragments of syntactic structure are shown below:

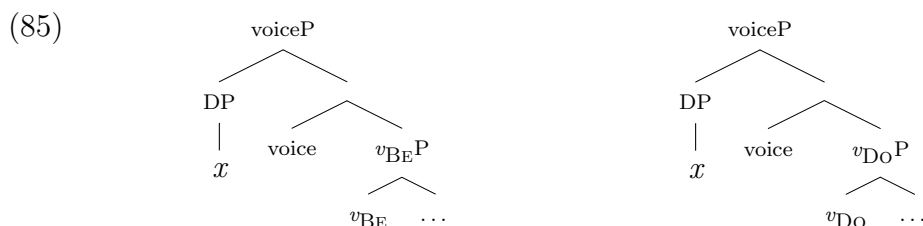

In Mandarin, this particular structural configuration involving an unmodified verbalizing head above another set of verbal projections conveys the semantics of a generic cause. In the case of v_{BE} , a state brings about another subevent; this is best paraphrased as “some property of x causes...” In the case of v_{Do} , since it is unmodified by an activity root and shares no arguments with the rest of the event,

the entire structure can be simply paraphrased as “*x* causes. . .” Furthermore, the causal relationship connecting the subevents can be flexibly interpreted; as an example, (84b) could be used to describe a scenario where Lisi got Zhangsan drunk by ordering Wongwu to pour alcohol down Zhangsan’s throat.

I do not have a good account of double-activity compounds and non-resultative activity-state compounds. Although a similar complex adjoined head analysis can be applied to activity-activity combinations, an alternative account based on covert coordination is also possible (see Baker, 1989; Baker and Stewart, 1999). Unlike double-state compounds, where it is obvious that one stative root encodes the primary result, while the second serves a subordinate role, the semantic relationship between the two component activities in double-activity compounds is much less apparent.

Non-resultative activity-state compounds present an even more complicated story. In a complex adjoined head account, which root should adjoin to which? Are these compounds primarily activities (but encode end states) or primarily end states (but also encode activities)? Since activities and states license their arguments in different ways, how would the argument sharing be accomplished? Would an analysis based on covert coordination better account for these facts? I will leave the resolution of these issues for future research.

3.6 Control

One major goal of my inquiry into the nature of verbal argument structure is to ground it in semantic primitives and the structure of events, on the one hand, and to ground it in independently-motivated syntactic principles, on the other hand. In my structural analysis of resultative constructions, control is employed to mediate argument sharing—to capture the fact that a DP may be semantically related to more than one predicate. As such, it is worthwhile to closely examine theories of control in the context of my syntactic framework. In the words of Bresnan (1980:372), control refers to “a theory of referential dependency between an unexpressed subject (the controlled element) and an expressed or unexpressed constituent (the controller). The referential properties of the controlled element. . . are determined by those of the controller.”

What evidence do we have that control is the correct analysis of argument sharing in Mandarin RVCs? Huang (1992) presents some evidence that resultatives in Mandarin pattern with control constructions. I summarize two of his points here.

Visser (1973) proposes the restriction that only object-control predicates can undergo passivization (whereas subject-control predicates cannot). Consider the following examples in English:

- (86) a. Bill is persuaded [PRO to leave].
b. *Bill is promised [PRO to leave].

Mandarin RVCs appear to obey Visser’s Generalization. A passivized object-control RVC is perfectly acceptable, as in (87), but the passive of a subject-control resultative is ungrammatical, as in (88).

(87) *shu₄ bei₄ Zhang₁san₁ kan₃ dao₃ le₅*
 tree BEI Zhangsan chop fall LE
 ‘The tree was chopped down by Zhangsan.’

(88) **fan₄ bei₄ Zhang₁san₁ chi₁ bao₃ le₅*
 meal BEI Zhangsan eat full LE
 intended: ‘The meal was eaten full by Zhangsan.’

Bach (1979) observes that only subject-control verbs, but not object-control verbs, can omit their objects. In English:○

- (89) a. John promised [PRO to leave].
 b. *John persuaded [PRO to leave].

Mandarin RVCs appear to follow Bach’s Generalization and also displays this contrast. An object-control resultative such as the example in (90) is ungrammatical without a direct object, while a subject-control resultative can freely omit its object, as in (91).

(90) **Zhang₁san₁ kan₃ dao₃ le₅*
 Zhangsan chop fall LE
 intended: ‘Zhangsan chopped down.’

(91) *Zhang₁san₁ chi₁ bao₃ le₅*
 Zhangsan eat full LE
 ‘Zhangsan ate himself full.’

Given that Mandarin resultative verb compounds pattern with familiar control constructions, obeying both Visser’s and Bach’s Generalization, one could conclude that a control-based analysis of resultatives is on the right track. The next question to ponder, naturally, is which specific model of control to adopt.

Government and Binding Theory had a well-developed, theory-internal account of control phenomena. There were four different types of empty categories: A’-trace, A-trace, pro, and PRO, which could be broken down in terms of the features \pm anaphoric, \pm pronominal (Chomsky, 1981, 1982). As PRO is +anaphoric and +pronominal, it is subjected to both Principles A and B of Binding Theory. Principle A requires PRO to be bound locally, i.e., within its governing category, but Principle B requires it to be free in the same domain. The only way to resolve this contradiction is to assume that PRO has no governing domain, i.e., it can only appear in ungoverned positions. This result is known as the PRO Theorem.

Within the Minimalist Program, Chomsky (1995) completely abandons the basic account of empty categories described above. As an alternative, Chomsky and Lasnik (1995) associated PRO with null case, which can only be checked by a non-finite I. Although this captures the descriptive generalization that PRO can only be found

in the subject position of non-finite clauses, the existence of null case can not be independently established.

Although control has been an intensely debated topic over the last decade, no clear consensus on a truly Minimalist theory of control has emerged. Many important insights have been gained through various discussions, but control theory is still in a state of flux. Since the earliest days of generative grammar (Rosenbaum, 1967), control has been distinguished from raising; recent emergence of control-as-movement accounts, however, challenge this fundamental assumption (Martin, 1996; O’Neil, 1997; Hornstein, 1999). For example, in an attempt to eliminate both PRO and the “control module” from the grammar, Hornstein (1999) argues that both obligatory control and raising are instances of DP-movement. The only difference, he claims, is that the DP is θ -marked once in raising but twice in control. Hornstein’s account of non-obligatory control is simple: a small pro is inserted in the controlled position as a last resort when movement is not possible. More recently, however, flaws in Hornstein’s control-as-movement theory have been pointed out by Landau (2003), who notes that Hornstein’s account not only overgenerates non-existent structures and interpretations, but also fails to derive a wide range of well-known control/raising contrasts; see also (Culicover and Jackendoff, 2001). These criticisms, however, do not prove that the movement approach to control is invalid; they merely point to holes in the current line of argumentation.

It is generally accepted that control can be divided into two types, *obligatory* and *non-obligatory* (Williams, 1980). While most linguists believe that this distinction is necessary for any satisfactory account of control, the actual classification of infinitival constructions, along with clear-cut diagnostics, is still a matter of debate. To further complicate the situation, the literatures distinguishes several more types of control. Consider the following examples (from Wurmbrand, 2002):

- (92) a. John tried to leave.
b. It is dangerous for babies to smoke around them.
c. It was difficult to leave.
d. John persuaded Mary to leave together.
e. We thought that the chair preferred to gather at six.

The example in (92a) represents a prototypical instance of obligatory control, also called *exhaustive control* (Landau, 1999); the infinitival subject refers exhaustively to the matrix subject John. The example in (92b), where the reference of the infinitival subject is left unspecified, typifies *arbitrary control* (Kawasaki, 1993). *Implicit control* is demonstrated by (92c), where the implicit argument of *difficult* acts as the controller. Example (92d) involves *split control*, where the matrix subject and object both serve the controller. *Partial control* is shown in (92e), where the controller is a subset of the individuals acting as the subject of the infinitival clause. Finally, the phenomenon of *variable control* is best illustrated an example from German (from Wurmbrand, 2002):

- (93) *Ich_i habe ihm_j angeboten [PRO_{i/j} mich zu erschießen]*
 I have him-DAT offered PRO me/myself to shoot
- i. ‘I offered him to shoot myself.’
 - ii. ‘I offered him that he could shoot me.’

In German, as well as many other languages, the infinitival subject can refer to either the subject or the object of the matrix clause. It is an open question whether this phenomenon is the same as the subject- vs. object-control ambiguity present in some Mandarin resultative verb compounds.

A comprehensive theory of control is well beyond the scope of this work, and I have nothing substantial to contribute from the point of view of syntactic theory. A description of the types of control involved in Mandarin RVCs, however, is well-warranted. The following shows different patterns of control observed in Chinese (for simplicity, only English glosses are used):

- (94)
- a. he cry handkerchief wet
 - b. I_i laughed PRO_i die
 - c. Zhangsan_j chop tree_i PRO_{i/*j} fall
 - d. Lisi_j eat meal_i PRO_{*i/j} full
 - e. Wongwu_j ride horse_i PRO_{i/j} tired

Example (94a) shows a non-selected, object-control resultative verb compound; it displays no control since the subject of the *wet* is not an argument of *cry*. Example (94b) shows a subject-control resultative verb compound, where the PRO refers to the subject of the entire compound. This appears to be a clear-cut case of exhaustive control (Landau, 1999). Examples (94c-e) show cases where the direct object of the entire compound is a semantic argument of V₁ (selected RVCs). There are three possibilities: PRO can either refer to the object of V₁ exclusively (94c), the subject exclusively (94d), or both (94e).

These patterns of control have bearing on the status of the Minimal Distance Principle (MDP), originally formulated by Rosenbaum (1967), which states that PRO is always controlled by the closest c-commanding DP. Here is Larson’s (1991) version of the MDP:

- (95) An infinitive complement of a predicate P selects as its controller the minimal c-commanding noun phrase in the functional complex of P.

Although this correctly predicts subject control in (96a) and object control in (96b), the MDP makes the wrong prediction with respect to (96c); object control is predicted, but not observed.

- (96)
- a. John_i wanted PRO_i to leave.
 - b. John_i persuaded Mary_j PRO_{*i/j} to leave.

- c. John_i promised Mary_j PRO_{i/*j} to leave.

Two solutions to this dilemma have been proposed in the literature. One is to downplay the importance of *promise*-type verbs, labeling them as “exceptions” of some sort. Proponents of this approach treat examples like (96c) as being “highly marked”, as evidenced by their late acquisition (Chomsky, 1969). The other solution to this problem is to construct sophisticated structural analyses that prevent Mary from being a controller in (96c), e.g., Larson’s (1991) double object proposal. Along the same lines, Hornstein (2001) suggests that the direct object of *promise* is actually the object of a null preposition. Since *Mary* does not c-command the PRO, no control relation can be established. It is argued that this null preposition is overtly realized in the nominal form:

- (97) a. John’s promise to Mary to leave
 b. John promised [_{PP} P Mary] [PRO to leave]

Many linguists, however, agree that controllers cannot be solely picked by distance in a purely structural theory—semantics and pragmatics must also be taken into account (Manzini, 1983; Chierchia, 1984; Koster, 1984; Farkas, 1988; Wurmbrand, 1998; Landau, 1999). Chierchia (1984), for example, denies the relevance of syntax in the determination of a controller. Instead, it is suggested that obligatory control infinitives do not involve subjects, i.e., they are properties instead of propositions. Control relations, therefore, are reduced to entailments determined by context. Along similar lines, Wurmbrand (2002) boils control down to two independent, irreducible properties: a *semantic* distinction between obligatory vs. non-obligatory control, and a *syntactic* distinction between subject-less infinitives and infinitives with an embedded subject. To Wurmbrand, obligatory control is determined lexically/semantically—it is an entailment relation built into the meaning of the selecting predicate.

This open debate notwithstanding, it appears that the Minimum Distance Principle suffices to capture all combinations of control in Mandarin RVCs. In the intransitive construction exemplified by (94b), the closest c-commanding DP is the external argument, and hence the sentence is interpreted as subject control. In the case of (94c), which has the structure shown in (62), the closest c-commanding DP is the direct object, licensed as the affected argument in the specifier position of v_{DO} ; this results in an object-control reading. A subject-control reading in the presence of a direct object, i.e., (94d), is possible because the object is not an affected argument, but rather idiosyncratically licensed by the verbal root (the object does not c-command the PRO). This results in a complex predicate interpretation, i.e., the activity of “meal-eating”, as shown in (69). Finally, both subject-control and object-control readings are available in (94e) because the horse can either be interpreted as an affected argument, as in (72), or as part of a complex predicate, as in (71). Without any additional stipulations, all observed control patterns in Mandarin RVCs can be account for by the Minimum Distance Principle.

Given this analysis, an interesting questions is why the sentence sketched in (94c) does not manifest a control ambiguity. Why can’t the tree be interpreted as an

idiosyncratically-licensed argument, i.e., the activity of tree chopping, resulting in a subject-control interpretation? More specifically, why can't Zhangsan fall as a result of chopping at the tree? In principle, this subject-control interpretation is possible, but is blocked by a speaker's knowledge of the real world. The event of chopping down trees is common enough to suppress the alternative reading of a person falling down as a result of chopping a tree (a somewhat bizarre scenario). In fact, we can see similar real world influences with the compound *qi₂ lei₄* 'ride tired':

(98) *Zhang₁san₁ qi₂ lei₄ le₅ zhu₁*
 Zhangsan ride tired LE pig
 'Zhangsan rode the pig, and ...'

- i. 'the pig got tired as a result.'
- ii. ?'Zhangsan got tired as a result.'

Contrast the above pig-riding example to the horse-riding example in (68). Since the activity of riding horses is common, it is easy to interpret the horse as a non-referential object that is idiosyncratically licensed by the verbal root. Since pigs are typically not ridden by humans, a complex predicate interpretation of pig-riding is much less salient. As a result, the subject-control interpretation of (98) sounds somewhat odd. In other words, real-world associations between verbs and objects determine the saliency of the possible interpretations; for the same reason, a subject-control reading of *kan₃ dao₃* 'chop fall' is unavailable.

A nice theoretical consequence of my control analysis of resultatives is the reduction of the Direct Object Restriction to the Minimum Distance Principle. Although I feel that the abandonment of the DOR in English is premature and unmotivated,⁸ I do not view the restriction as an independent principle of language. Rather, the generalization arises from the interaction between restrictions on controllers and the structural position of arguments. In Mandarin, the DOR is apparently violated because the closest c-commanding argument is sometimes the direct object, and sometimes the external argument. In English, however, the following structure is not allowed:

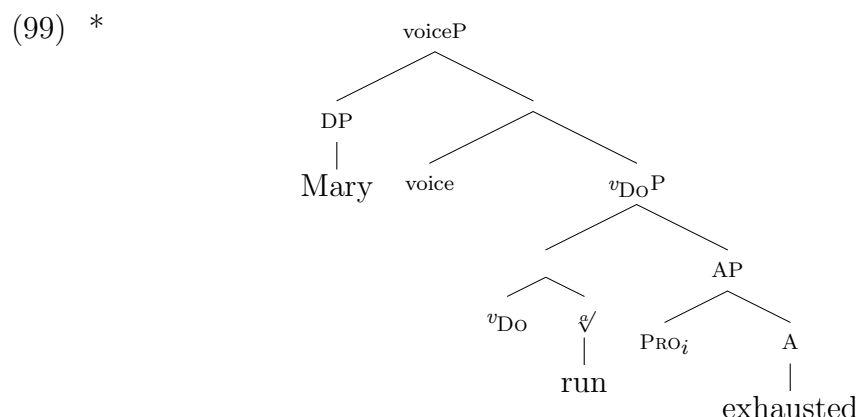

⁸I have presented evidence in Section 3.3.1 on why Wechsler's counterexamples do not actually pattern with true resultatives.

There appears to be a restriction in English on the ability of an external argument, i.e., one licensed by *voice*, to serve as a controller. As a result, a reflexive must be inserted:

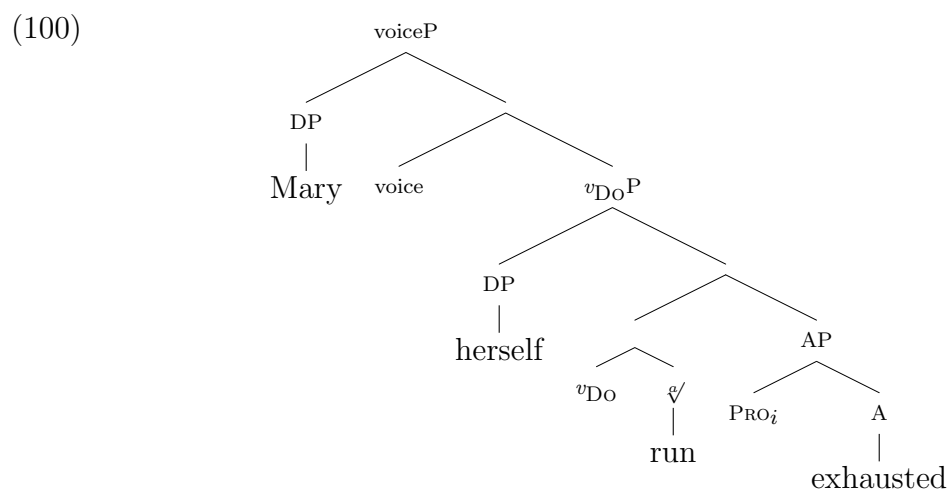

With this stipulated parameter that governs whether or not an external argument can serve as a controller, the generalizations captured by the Direct Object Restriction (and the violation thereof in Mandarin) boil down to the Minimum Distance Principle. In short, PRO simply selects the closest *c*-commanding DP as its controller.

Another noteworthy issue that warrants discussion is the structural configuration of the control relation. Does the controller need to *c*-command the PRO? More generally, do all grammatical relations invoke *c*-command? Since I argue that idiosyncratically-licensed objects cannot receive an object-control interpretation because the object does not *c*-command the PRO, the necessity of such a structural relationship is a key concern.

Kiguchi (2000) and Kiguchi and Hornstein (2002) have studied the relation between *c*-command and control in depth, and they raise many interesting cases where the controller does *not* *c*-command the PRO, and could not have at any point during the derivation process. They focus on the so-called “PRO gate” phenomenon (Higginbotham, 1980), whereby PRO appears to cancel out Weak Cross Over effects:

- (101) a. Who_{*i*} did [PRO_{*i*} shaving his_{*i*} face] annoy *t_i*?
 b. [PRO_{*i*} getting his_{*i*} car fixed] upset everyone_{*i*}.

In addition, some languages exhibit “backward control”, where the controller appears to be structurally lower than the controlled element: the Caucasian language Tsez (Polinsky and Potsdam, 2001) and Korean (Monahan, 2003) are two such languages. Kiguchi (2000) further notes more examples of the *c*-command violations in grammatical relations:

- (102) a. Which book_{*i*} did you file *t_i* before reading *t_i*? (Parasitic Gap)
 b. Which book_{*i*} did John file *t_i* and Mary read *t_i*? (Across The Board Extraction)

- c. John read every book_{*i*} before it_{*i*} was published.
- d. Someone from every city_{*i*} hates it_{*i*}.

In the first two examples, each variable is not in a c-command relation with the other. In the second two examples, the quantifiers successfully bind the pronouns without c-commanding them. Finally, Pesetsky (1995:45) provides examples of backward binding, where binding occurs in the absence of c-command:

(103) [Each other'_{*j*}s remarks]_{*i*} made t_{*i*} [John and Mary]_{*j*} seem t_{*j*} to be angry.

Consider another example along the same lines where the indirect object can bind a reciprocal in the adjunct without c-commanding it:

(104) John and Mary will buy themselves presents on each other's birthdays.

Where, then, does the supposed primacy of the c-command relation come from? In a strict derivational approach to grammar, it follows naturally out of the operations MERGE and MOVE. If one believes, as Epstein (1999) claims, that “no relations hold between members of two trees that were unconnected at any point in the derivation”, then the c-command property is necessarily a primitive involved in all aspects of the derivation.

Nunes (1995) notes, however, that if movement is the interaction between two distinct operations, COPY and MERGE, then a phenomenon called sideward movement, where the operations are uncoupled, is both theoretically possible and empirically motivated. Sideward movement is a derivation that involves two independent sub-trees, α and β , where an item, say γ , is copied from α and merged with β :

- (105) a. [$\alpha \dots \gamma \dots$] [$\beta \dots$] (Two independent trees)
 b. [$\alpha \dots \gamma \dots$] γ [$\beta \dots$] (Copying γ in α)
 c. [$\alpha \dots \gamma \dots$] [γ [$\beta \dots$]] (Merging the copy with β)

Nunes uses sideward movement to account for parasitic gap and across the board extraction. Kiguchi (2000) and Kiguchi and Hornstein (2002) take advantage of this process to account for PRO gate effects. Hornstein (1999) similarly employs the device to explain control into adjuncts. Naturally, the mechanism of sideward movement has the potential to vastly overgenerate non-existing structures. The validity of this mechanism and constraints acting thereon are still a matter of ongoing debate.

In this section, I have discussed many of the issues surrounding control that are critical to my syntactic analysis of Mandarin resultative verb compounds. While the evidence in Mandarin supports a simple theory of control based on the Minimum Distance Principle, I have raised a few other issues regarding the status of c-command in control relations. There are still many issues left unresolved in formulating a Minimalist theory of control, but Mandarin RVCs can serve as important pieces of evidence that will contribute to this discussion.

3.7 Causation and the External Argument

Up until now, my syntactic analysis of Mandarin resultative verb compounds has primarily focused on variations in their internal arguments. In this section, I will shift focus to the external arguments of RVCs.

It appears that object-control resultative verb compounds (whether selected or non-selected) can undergo an alternation whereby the external agent is omitted, and the object appears in the pre-verbal subject position (this is what I previously dubbed the reduced RVC):

- (106) a. *shu₄ kan₃ dao₃ le₅*
tree chop fall LE
'The tree got chopped down.'
- b. *shou₃pa₄ ku₁ shi₁ le₅*
handkerchief cry wet LE
'The handkerchief got wet from crying.'
- c. *qi₄qui₂ chui₁ po₄ le₅*
balloon blow broken LE
'The balloon got popped from blowing.'

Cheng and Huang (1994) argue persuasively that these constructions should not be analyzed as topicalized sentences with a PRO subject, which I will not repeat here. I will, however, contribute an additional piece of evidence against the existence of a null subject. Consider the following example:

- (107) *ma₃ qi₂ lei₄ le₅*
horse ride tired LE
- i. 'The horse got tired from someone riding it.'
- ii. ??'Someone got tired from riding the horse.'

In the agentive, transitive sentence, e.g., (68), there exists an ambiguity between the horse or the rider getting tired as a result of the riding. In (107), however, the reading in which the rider becomes tired is unavailable. This points to the lack of a covert subject, thereby casting doubt on the topicalization account.

What, then, is the proper analysis of such constructions? I will present two competing hypotheses and attempt to reconcile them within my syntactic framework. Sybesma (1999) argues that reduced RVCs are unaccusatives, whereas Cheng and Huang (1994) analyze them as instances of the middle construction.

It has long been noticed in Mandarin that a certain class of verbs allow post-verbal subjects, which Travis (1984) determined to be the unaccusative verbs. Consider the following contrast:

- (108) a. *dao₃ le₅ ji₃ ke₁ shu₄*
fall LE a.few CL tree
'A few trees fell.'

- b. **ku*₁ *le*₅ *ji*₃ *ge*₅ *ren*₂
 cry LE a.few CL person
 ‘A few people cried.’

An unaccusative verb such as *dao*₃ ‘fall’ (in the presence of *le*) allows its subject to appear after the verb, whereas a post-verbal subject is ungrammatical with an unergative verb such as *ku*₁ ‘cry’. Sybesma (1999) employs this diagnostic to demonstrate that verbal compounds such as those in (106) do, in fact, pattern with unaccusatives. Consider the following examples:

- (109) a. *xiao*₄ *si*₃ *le*₅ *yi*₁ *xie*₁ *ren*₂
 laugh dead LE one some person
 ‘Some died laughing.’
 b. *chui*₁ *po*₄ *le*₅ *bu*₄ *shao*₃ *qi*₄*qui*₂
 blow broken LE not few balloon
 ‘Many balloons were popped (from blowing).’

There are, however, doubts concerning the validity of the post-verbal test as a diagnostic of unaccusativity. Levin and Rappaport Hovav (1995) argue against all surface tests of unaccusativity as true diagnostics of unaccusativity. In particular, they persuasively show that restrictions on locative inversion stem from discourse factors, not unaccusativity.

Cheng and Huang (1994), on the other hand, analyze reduced RVCs as instances of the middle, akin to the following in English:

- (110) a. John angers easily
 b. This theory won’t sell.
 c. The meat slices like butter.

Naturally, a full theory of the middle construction is beyond the scope of this work, but I will attempt to synthesize previous results and the intuition of other linguists into my syntactic framework. Studies on the middle construction are too numerous to mention here, but (Fagan, 1992; Hale and Keyser, 1999a; Rapoport, 1999), and references therein represent a good start.

What exactly is the difference between the middle and unaccusative (and also the passive), and how can these distinctions be syntactically captured? Most linguists agree that middles can be formed from activities and accomplishments (naturally, subjected to other semantic restrictions), so let us consider the two basic cases:

- (111) a. The vase broke.
 b. The vase breaks easily.
 (112) a. *The bread cuts.
 b. The bread cuts easily.

Example (111b) shows a middle formed from a change of state verb, contrasted against its unaccusative form in (111a). The relevant intuition behind the difference is that the middle implies some sort of causing process, whereas the unaccusative form does not. The English middle in this case appears to assert some property about an object; whether or not this construction is truly eventive is open to debate.⁹ Nevertheless, one possible paraphrase for (111b) is “the process by which the vase can be broken is easy”. On the other hand, middles formed from activities (112b) do not contrast with an intransitive form corresponding to the unaccusative (more evidence that objects in these cases are not structurally licensed). These constructions assert a property about an activity; I argue that (112b) should be paraphrased as “the activity of cutting bread is easy”.

These intuition can be syntactically captured in the structures shown in (113). In the middle construction, the adverbial element can be analyzed as modifiers of the upper verbal projection, as I have conveyed in the paraphrases above.

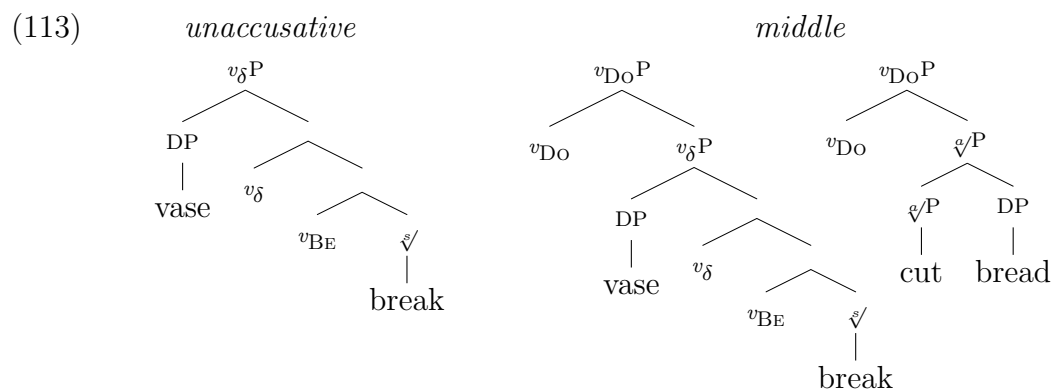

What of the distinction between middles and true passives? Consider the contrast between passives, e.g., (114a) and (115a), and their middle counterparts in (114b) and (115b).

- (114) a. The vase was broken (by John).
 b. The vase breaks easily.

- (115) a. The bread was cut (by Mary).
 b. The bread cuts easily.

It is a well-known fact that implicit agents are present in passives, but missing from middles and unaccusatives. Asymmetries with respect to control provide the best evidence for this fact:

- (116) a. The ship was sunk to collect the insurance money.
 b. *The ship sinks easily to collect the insurance money.

⁹For example, it has been argued that the middle only denotes the possibility of an event. Alternatively, the middle construction may refer to actual previous events.

- c. *The ship sank to collect the insurance money.

In (116a), the external argument has some implicit realization, which manifests in its ability to control the PRO subject of the infinitive, even without an explicit *by*-phrase (cf. Manzini, 1983). Evidence with agent-oriented adverbs and other phrases provides additional evidence:

- (117) a. *This bread cuts (easily) deliberately.
 b. *This bread cuts (easily) by skilled bakers.

Once again, the separation of a causing activity (i.e., v_{Do}) from the licensing of the external argument (i.e., *voice*) is the key insight that allows reconciliation of these facts. I believe that *voice* is present in passives (but the external argument is suppressed by the passive morphology), but *voice* is entirely missing in middles. Compare the passive structures in (118) with the middles and unaccusatives in (113).

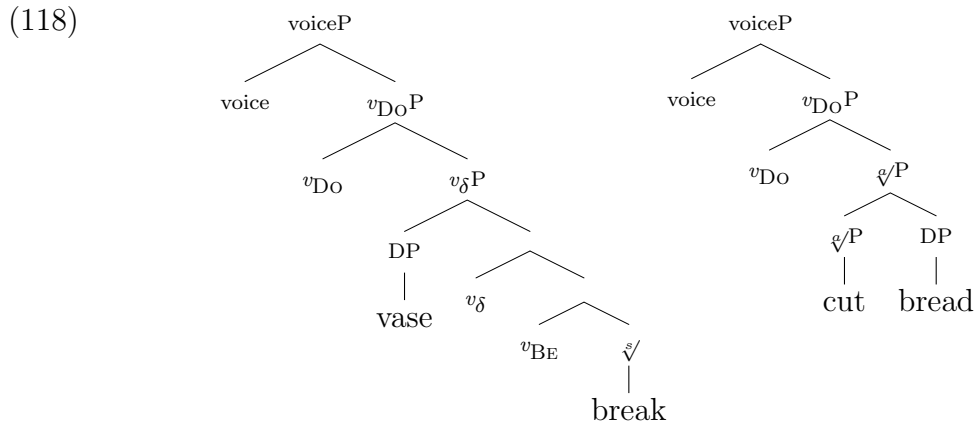

Naturally, an account of the middle construction based solely on syntax is bound to fail. A variety of semantic factors contribute to the licensing of middles, and there is nothing to prevent them from being recast into my framework. I have briefly sketched what a theory of middles would look like in my theory of argument structure; a more detailed account will be saved for future work.

Given this superficial discussion of middles and unaccusatives, it appears that reduced resultative verb compounds in Mandarin behave more like the middle construction. One argument presented by Cheng and Huang (1994) is the ability to paraphrase reduced RVCs with a passive (recall that middles and passives differ only in the presence or absence of *voice*), whereas subject-control RVCs, which are superficially similar, cannot be.

- (119) a. $qi_4 qui_2 \quad chui_1 \quad po_4 \quad le_5$
 balloon blow broken LE
 ‘Many balloons popped (from blowing).’
 b. $qi_4 qui_2 \quad bei_4 \quad chui_1 \quad po_4 \quad le_5$
 balloon BEI blow broken LE
 ‘Many balloons were popped (from blowing).’

- (120) a. *Li₃si₄ pao₃ lei₄ le₅*
 Lisi run tired LE
 ‘Lisi ran himself exhausted.’
- b. *Li₃si₄ bei₄ pao₃ lei₄ le₅*
 Lisi BEI run tired LE himself
 ‘Lisi was caused to run by someone to the point of exhaustion.’

Whereas (119a) and (119b) are nearly synonymous, (120b) means something quite different than (120a). Since reduced RVCs in Mandarin clearly imply an activity (given the presence of V_1), analyzing them as unaccusatives appears to be untenable. I agree with Cheng and Huang’s account of these constructions as middles. However, they argue that the middle is derived as a result of argument-suppression (of the agent) followed by NP-movement. This is not the case in my analysis: middles do not project an external agentive argument to begin with, and there is no “argument suppression” of any sort.

Having determined the correct classification of reduced resultative verb compounds, I suggest that (106b) has the structure shown in (121), and (106c) has the structure shown in (122). As I have argued, the only difference between these structures and their transitive counterparts is the absence of *voice* and the external argument.

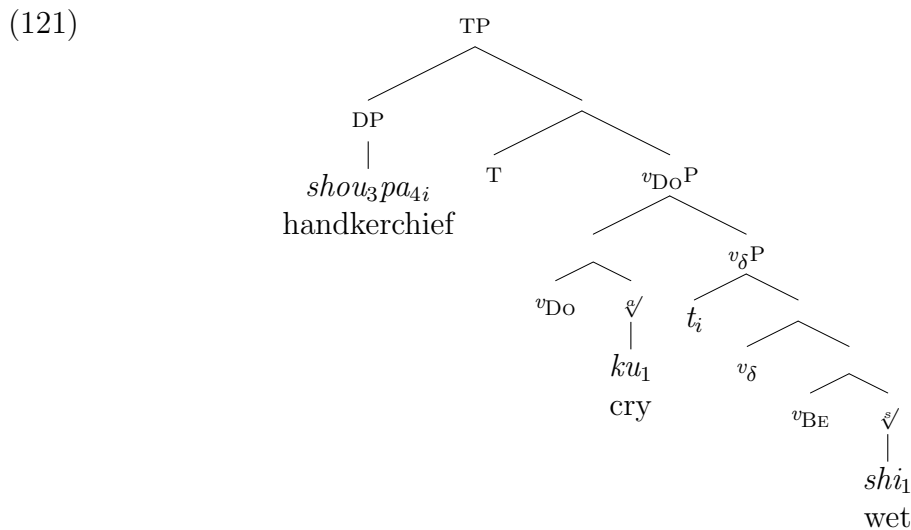

(122)

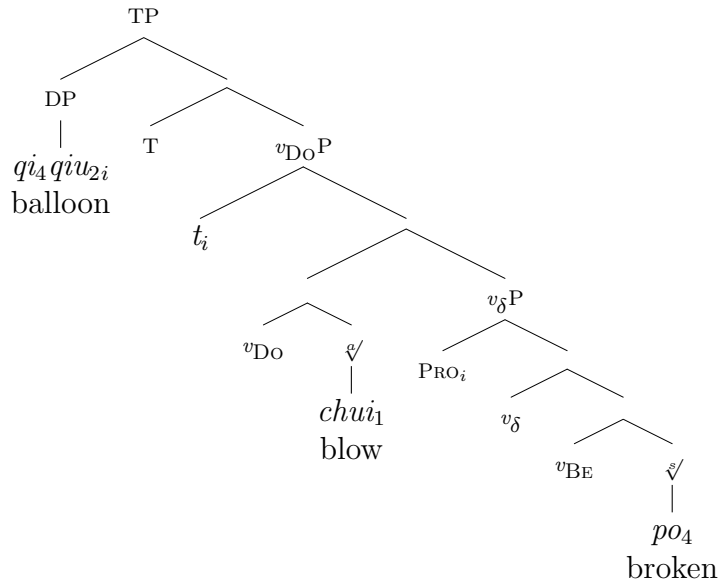

Consider the inalienable possession alternation exhibited by some object-control RVCs, repeated from (49):

- (123) a. *Zhang₁ san₁ xiao₄ tung₄ le₅ du₄ zi₅*
 Zhangsan laugh hurt LE stomach
 ‘Zhangsan laughed so hard that his stomach hurt.’
- b. *Zhang₁ san₁ de₅ du₄ zi₅ xiao₄ tung₄ le₅*
 Zhangsan DE stomach laugh hurt LE
 ‘Zhangsan’s stomach hurt from laughing so hard.’

Example (123b) should be assigned the same structure as the reduced RVC depicted in (121):

(124)

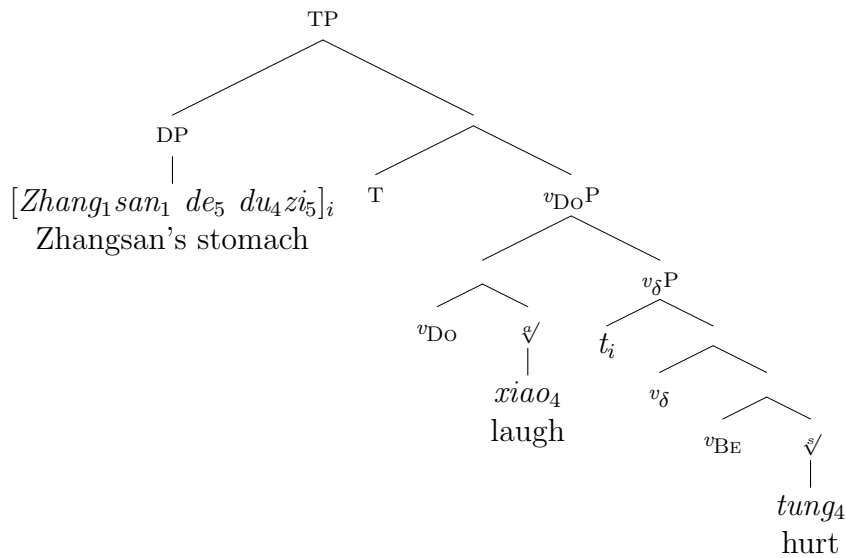

*Zhang*₁*san*₁ *de*₅ *du*₄*zi*₅ ‘Zhangsan’s stomach’ ends up in a state of hurting, and a laughing event is implicated. Naturally, there is no semantic relationship between the verb *xiao*₄ ‘laugh’ and the stomach.

Another interesting phenomenon in Mandarin is the possibility of having an external argument of a resultative verb compound that bears no semantic relationship to either *V*₁ or *V*₂, and can only be interpreted as a generic cause. Subject-control RVCs (and reduced RVCs) can participate in this type of alternation.

- (125) a. *Zhang*₁*san*₁ *he*₁ *zhui*₄ *le*₅
 Zhangsan drink drunk LE
 ‘Zhangsan drank himself drunk.’
- b. *na*₄ *ping*₂ *jiu*₃ *he*₁ *zhui*₄ *le*₅ *Zhang*₁*san*₁
 that bottle wine drink drunk LE Zhangsan
 ‘That bottle of wine got Zhangsan drunk.’
- (126) a. *wo*₃ *xiao*₄ *si*₃ *le*₅
 I laugh die LE
 ‘I laughed myself to death.’
- b. *na*₄ *jian*₄ *shi*₄ *xiao*₄ *si*₃ *le*₅ *wo*₃
 that CL matter laugh dead LE I
 ‘That matter caused me to laugh to death.’
- (127) a. *Li*₃*si*₄ *de*₅ *yan*₃*jing*₁ *ku*₁ *hung*₂ *le*₅
 Lisi DE eye cry red LE
 ‘Lisi’s eyes got red from crying.’
- b. *na*₄ *feng*₁ *xin*₄ *ku*₁ *hung*₂ *le*₅ *Li*₃*si*₄ *de*₅ *yan*₃*jing*₁
 that CL letter cry red LE Lisi DE eye
 ‘The contents of that letter caused Lisi to cry so much that his eyes became red.’

The example pairs in (125) and (126) represent an alternation between a subject-control RVC and its corresponding causative form. The semantic relationship between the subject and the verbal compound in the non-causative form is exactly the same as the semantic relationship between the object and the compound in the causative form. The pair in (127) shows an example of the same alternation based on a reduced resultative verb compound.

How should these causative constructions be analyzed? Recall from the discussion in Section 1.2.2 that causation is a relationship between two eventualities, not between an entity and an eventuality. However, it appears here that the external argument is directly interpreted as the causer. This difficulty can be reconciled by the theory of *voice*, which relates an external argument to an event. One of the possible relationships is identity, i.e., equating the external argument and the causing activity. A sentence such as “The explosion broke the window” can be paraphrased

as “there exists an event that caused the window to become broken; the explosion *is* that event”.

This analysis can be applied to capture slight differences in the interpretation of psychological causative predicates (*frighten*-type verbs):

- (128) a. John angered Mary.
 b. John angers Mary.

I believe that sentence (128a) is best paraphrased as “John did something that caused Mary to be angry”. The ability to follow the example with another sentence such as “It happened last week” suggests the existence of the implicit activity. Paralleling this analysis, sentence (128b) is best paraphrased as “some property of John causes Mary to become angry”. It is, however, difficult to come up with a sentence that anaphorically refers to the property—this might be attributed to the lack of state variables associated with states; see Parsons (1990) and Katz (2000) for differing views. The eventive cause interpretation and the stative cause interpretation are both shown below:

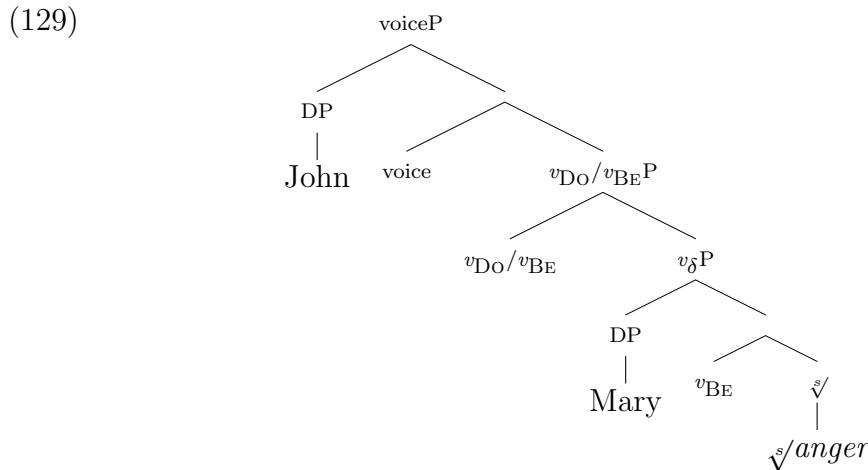

If the upper verbalizing head is v_{DO} , then we get the interpretation in (128a); if the upper verbalizing head is v_{BE} , we get interpretation in (128b). In both cases, however, *voice* establishes the correct relationship between the external argument and the eventuality.

Once again, I have no pretense in providing a complete theory of psychological predicates; my only goal is to demonstrate what such a theory might potentially look like in my framework. For a much more comprehensive account of psych predicates, see Pesetsky (1995) and references therein. McGinnis (2000) provides a more recent treatment of these issues in a Distributed Morphology framework that is very similar in spirit to mine.

We can apply a similar analysis to Mandarin causative RVCs shown in (125), (126), and (127). As a specific example, the syntactic structure of (126) is the following:

(130)

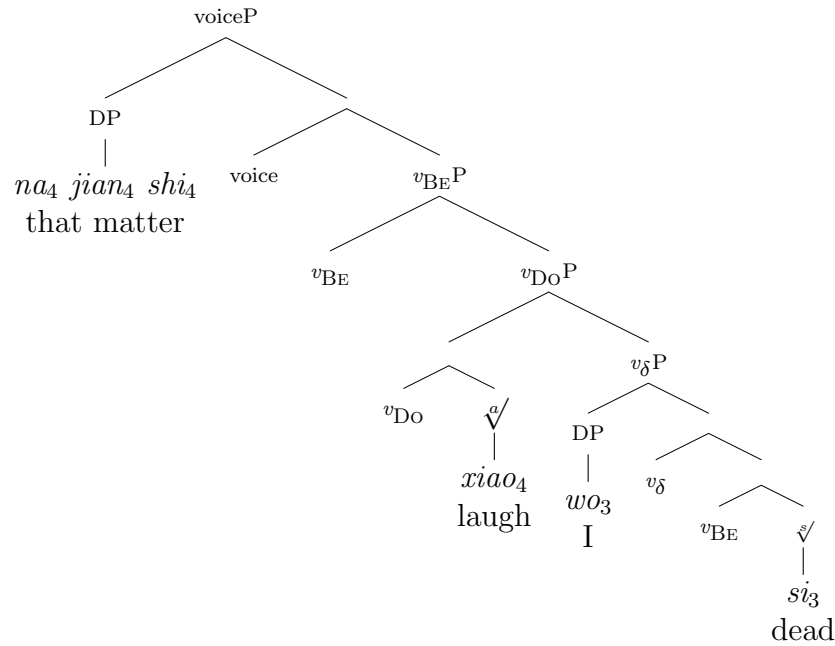

The above structure can be paraphrased as “some property (state) of that matter caused a laughing activity in which I become dead (metaphorically)”. This analysis preserves the assumption that causation is a relationship between eventualities, and furthermore accounts for the interpretation of the external argument as a non-agentive causer. The *voice* head establishes the correct semantic relationship between *na₄ jian₄ shi₄* ‘that matter’ and the state licensed by *v_{BE}*. This represents the same exact situation as described in (85).

The structure shown in (130) appears to represent the limit in the complexity of events that can be denoted by a single clause. The final result is a tri-eventive structure whereby a state causes an activity, which in turns causes a change of state. Critically, however, the upper *v_{BE}* cannot be modified by a stative root because it would interfere with the ability of *voice* to establish a proper semantic relationship between the external argument and the eventuality in its complement.

These causatives in Mandarin are similar to Finnish desiderative constructions. In Finnish, it is possible to causativize unergative verbs without introducing a new argument in the syntax (further supporting the separation of the causing activity and *voice*). Consider the following examples, taken from (Pylkkänen, 2002:86):

- (131) a. *Maija-a laula-tta-a.*
 Maija-PART sing-CAUSE-3SG
 ‘Maija feels like singing.’
- b. *Maija-a naura-tt-a.*
 Maija-PART laugh-CAUSE-3SG
 ‘Maija feels like laughing.’

Since object case in Finnish is partive, it is clear that subjects in the above sentences are derived via movement. These desiderative constructions are also stative

because they allow a non-habitual interpretation in the present tense; see (Pylkkänen, 2002) for more detailed discussions. Thus, a better paraphrase for the above sentences might be “something makes me feel like dancing/singing.” Under this view, the causative morpheme in Finnish introduces the causing event (i.e., the “something” in the paraphrase), without introducing a new argument. This is most evident in the follow example, from (Pylkkänen, 2002:89), where the presence of the causing event is clearly demonstrated by its ability to be questioned.

- (132) *Minu-a naura-tt-a mutt-en tiedä mikä*
 I-PART laugh-CAUSE-3SG but.not-1SG know what-NOM
 ‘Something makes me feel like laughing but I don’t know what (makes me feel like laughing).’

Mandarin is not unique among languages in allowing such a well-articulated verb phrase structure, providing the possibility of encoding up to three subevents in a single clause. Pylkkänen (2002:107–108) discusses “phase-selecting” causatives in Venda and Luganda, where even bigger fragments of event structure can be causativized:

(133) **Venda**

Reciprocal inside causative:

- vhona* ‘see’
- vhon-is-a* ‘cause to see’
- vhon-an-a* ‘see each other’
- vhon-an-is-a* ‘cause to see each other’

Reversive inside causative:

- tiba-* ‘put a lid on, cover’
- tiba-is-a-* ‘cause to put a lid on, cover’
- tib-ul-a-* ‘remove a lid’
- tib-ul-is-a-* ‘cause to remove a lid’

Applicative inside causative:

- tshimbila* ‘walk’
- tshimbi-dz-a* ‘make walk’
- tshimbil-el-a* ‘walk for’
- tshimbil-e-dz-a* ‘make [walk for]’

(134) **Luganda**

Reciprocal inside causative:

- laba-* ‘see’
- laba-gana-* ‘see each other’
- laba-ga-za* ‘make see each other’

Stative inside causative:

- laba-* ‘see’

- lab-ik-a-* ‘be visible, appear’
- lab-i-s-a-* ‘make visible’

Applicative inside causative:

- tambula-* ‘walk’
- tambu-za-* ‘make walk’
- tambul-ir-a* ‘walk for’
- tambul-i-z-a-* ‘make [walk for]’

The final interesting aspect of non-agentive, causative RVCs in Mandarin is the possibility of v_{Do} in the uppermost causing event, instead of v_{BE} . This corresponds to the two interpretations of a psychological causative such as *anger*: it could be a property of the external argument (most salient in the present tense) or an activity that the external argument engages in (most salient in the past tense) that causes that change of state. In (135b), one interprets that the external argument is engaged in an unspecified activity, which causes Zhangsan to get drunk. Importantly, Lisi is *not* an argument of V_1 .

- (135) a. *na₄ ping₂ jiu₃ he₁ zhui₄ le₅ Zhang₁san₁*
 that bottle wine drink drunk LE Zhangsan
 ‘The bottle of wine got Zhangsan drunk.’
- b. *Li₃si₄ he₁ zhui₄ le₅ Zhang₁san₁*
 Lisi drunk fall LE Zhangsan
 ‘Lisi got Zhangsan drunk.’

An interesting question is why causative, non-agentive external arguments are not grammatical in English. Consider the following examples:

- (136) a. *That matter laughed me to death.
 b. *Those errands ran me exhausted.

Mandarin equivalents of these resultatives are perfectly acceptable. Why is the tri-eventive structure outlined in (130) ungrammatical in English? I suggest that the voice bundling property proposed by Pytkänen(2002) can be invoked to account for this difference (see Section 1.2). It has been noted by many linguists that the *voice* head essentially “closes off” the event structure so that no other arguments can be licensed above it (not even high applicatives). The voice bundling hypothesis simply states that in some languages, *voice* and v_{Do} (CAUSE in Pytkänen’s terminology) are merged together in a complex head. The consequence is that a causing event cannot be introduced independently of the external argument (modulo middles and passives, which undergo further syntactic processes). The ungrammaticality of the sentences in (136) follows straightforwardly if one assumes that English is a voice bundling language.

Given this discussion, we now have enough syntactic machinery to account for a very interesting ambiguity with the RVC *zhui₁ lei₄* ‘chase tired’ (cf. Li, 1999). Note the following three-way ambiguity and the unavailability of a fourth reading:

- (137) *wo*₃ *zhui*₁ *lei*₄ *le*₅ *hu*₂*li*₂
 I chase tired LE fox
 i. ‘I chased the fox, and the fox got tired as a result.’
 ii. ‘I chased the fox, and I got tired as a result.’
 iii. ‘The fox chased me, and fox got tired as a result.’
 iv. *‘The fox chased me, and I got tired as a result.’

- (138) *wo*₃ *ba*₃ *hu*₂*li*₂ *zhui*₁ *lei*₄ *le*₅
 I BA fox chase tired LE
 ‘I chased the fox, and the fox got tired as a result.’

Reading (137i) is perhaps the most salient reading, and can be rendered the exclusive reading in the *ba* construction, which introduces the following DP as the affected argument (138). Alternatively, the fox can be viewed as an idiosyncratically licensed argument, i.e., the event of fox-chasing; this leads to the subject control interpretation in (137ii). The reading in (137iii), where the external argument is a generic (non-agentive) cause, is sometimes difficult to elicit, but nevertheless present. The interpretation becomes more salient given the following alternating pair:

- (139) a. *hu*₂*li*₂ *zhui*₁ *lei*₄ *le*₅
 fox chase tired LE
 ‘The fox got tired from chasing someone.’ (subject-control RVC)
 b. *wo*₃ *zhui*₁ *lei*₄ *le*₅ *hu*₂*li*₂
 I chase tired LE fox
 ‘The fox got tired from chasing me.’ (causative reading of previous)

The interpretation in (139b) is best paraphrased as “Something I did (e.g., running away) caused the fox to become tired from chasing me”. The inference that the fox was chasing me is drawn from real-world knowledge. The correct syntactic structure is similar to the one shown in (130), except that the outermost verbalizing head is a *v*_{DO} instead of a *v*_{BE}.

My analysis also explains the observed asymmetry and the unavailability of the fourth interpretation (137iv), where I become tired as a result of being chased by the fox. In the non-agentive, causative interpretation, the fox is explicitly the subject of the result phrase. Recall that the ambiguity between the first two readings arises from the different structural positions of the direct object, which leads to two possible antecedents for PRO. Since there is no PRO in the subject position of *V*₂, no ambiguity can arise.

As I have shown in the previous few sections, variations in the internal and external arguments of Mandarin resultative verb compounds can be captured in my syntactic framework. I have demonstrated how event and argument structure is built up from a primitive inventory of verbalizing heads and verbal roots, and how this system accounts for the syntactic and semantic variations observed in resultative constructions.

3.8 Semantic Restrictions and the *de* Construction

This section focuses on the connection between resultative verb compounds, where V_1 and V_2 are adjacent (which Sybesma calls *cluster resultatives*), and the *de* form, where an object intervenes between the two verbs. The difference between what I will call the canonical RVC form and the *de* resultative also bears relevance to the literal/phase RVC distinction. Thus far, I have primarily focused on literal resultative verb compounds.

Sybesma (1999:16) claims that “most [native speakers] sense no significant difference in interpretation between sentences with and those without *de*”. In fact, his explanation of *de* is reminiscent of English *do*-support. Sybesma posits a projection, ExtP or Extent Phrase, that intervenes between the matrix clause and the result clause. Typically, the head of the result phrase moves into the head of ExtP, but, as an alternative, *de* can be inserted as support.

I argue that the differences between the canonical and the *de* forms lie much deeper: canonical resultative verb compounds are mono-clausal structures involving complex event composition, while *de* resultatives are bi-clausal. I agree with Huang’s (1988) analysis of *de* as a complementizer. The strongest support for this is the ability of *de* constructions to encode complex, clausal results. Consider the following sentences, which have no RVC counterpart:

- (140) a. *Zhang₁san₁ he₁ de₅ zhan₄ bu₄ qi₃lai₂*
 Zhangsan drink DE stand not get.up
 ‘Zhangsan drank so much he couldn’t get up.’
- b. *Li₃si₄ wan₂ de₅ lian₂ shi₂jian₁ dou₁ wong₄ diao₄ le₅*
 Lisi play DE even time all forget drop LE
 ‘Lisi played so much he forgot about the time.’

Another prominent difference between the canonical compound form and the *de* form is their acceptability with phase resultatives. Consider the following contrast:

- (141) a. *Zhang₁san₁ ca₁ diao₄ le₅ hui₁chen₂*
 Zhangsan wiped drop LE dust
 ‘Zhangsan wiped off the dust.’
- b. **Zhang₁san₁ ca₁ de₅ hui₁chen₂ diao₄ le₅*
 Zhangsan wiped DE dust drop LE
 intended: ‘Zhangsan wiped off the dust.’
 possible: ‘Zhangsan wiped the dust onto the ground.’

In (141a), *diao₄* ‘drop’ does not describe the literal result of the dust (e.g., falling onto the floor); instead, the morpheme places extra emphasis on the result of the action, and specifically encodes completion (i.e., one cannot conjoin a clause that asserts the presence of the dust on the table, for example). The example in (141b), the *de* form of the compound does not have the same interpretation: the only available

reading is that the dust literally drops to the floor. In this scenario, (141b) would be felicitous.

Adopting Huang’s analysis of *de* as a complementizer, these effects can be straightforwardly explained. The formation of the canonical verbal compound involves movement of both V_1 and V_2 to *voice*, which derives the correct surface word order. The resulting configuration allows the licensing of idiosyncratic meaning, giving rise to either idiomatic or metaphoric interpretations of the verbal compounds. With an intervening *de*, however, this movement is not possible (because complementizers represent phase boundaries). As a result, only the literal meaning of the result is available. This accounts for the interpretation in (141b). This licensing of idiosyncratic meaning, enabled by head movement, is the only essential difference between literal and phase resultatives.

Such an explanation also accounts for the unacceptability of many compounds where V_2 is *si*₃ ‘die’ in the *de* construction. The use of *si*₃ ‘die’ under these circumstances is a common device to express the figurative effect of an event. For example, *xiao*₄ *si*₃, literally ‘laugh die’, means ‘to figuratively die from laughter’. The formation of the resultative compound licenses this metaphoric interpretation, which is blocked in the *de* construction. Thus, in the bi-clausal *de* resultative, the death of the subject must be literal for the sentence to be felicitous.

Phase resultatives in Mandarin appear to exactly parallel verb–particle constructions in English. My treatment is similar in spirit to the work of Ramchand and Svenonius (2002), but the actual details of the verbal decomposition differs. The overall goal is to synthesize the “small clause” approach, e.g., (den Dikken, 1995), and “complex predicate” approach, e.g. (Johnson, 1991), to verb–particle constructions, drawing on the advantages of both treatments.

Another difference between the verbal compound form and the *de* form of the resultative concerns the “sharing” of arguments. Recall from our example of chopping the tree down, the tree is both an argument of chopping and an argument of the falling. This is syntactically captured via control, and forces the interpretation that the fallen tree must have been the tree that was chopped. In the canonical compound form, there exist no readings other than the one involving direct causation. With the *de* form of the resultative, on the other hand, this type of object sharing does not appear to be present. The consequence is that *de* constructions impose a less stringent causal relationship between the subevents that it connects. Consider the following contrast:

- (142) a. **Zhang*₁ *san*₁ *kan*₃ *diao*₄ *le*₅ *shu*₄ *ye*₄
 Zhangsan chop drop LE tree leaf
 intended: ‘Zhangsan chopped the leaves down.’
- b. *Zhang*₁ *san*₁ *kan*₃ *de*₅ *shu*₄ *ye*₄ *diao*₄ *le*₅
 Zhangsan chop DE leaf drop LE
 ‘Zhangsan chopped to the extent that the leaves fell.’

Example (142a) cannot be used felicitously to refer to an event where Zhangsan hacked at the trunk of the tree and shook all the leaves off. The only possible interpretation is the literal one where Zhangsan chops each individual leaf off the tree.

The causal relationship between the event denoted by V_1 and the event denoted by V_2 must be direct. The semantic restrictions for the *de* construction, however, appear to be much looser, given the acceptability of (142b). Consider another contrasting pair:

- (143) a. **Zhang₁san₁ xiao₄ ku₁ le₅ Li₃si₄*
 Zhangsan laugh cry LE Lisi
 intended: ‘Zhangsan laughed so hard Lisi cried.’
- b. *Zhang₁san₁ xiao₄ de₅ Li₃si₄ ku₁ le₅*
 Zhangsan laugh DE Lisi cry LE
 ‘Zhangsan’s laughing got Lisi so upset that he cried.’

The event denoted by the second clause in the *de* construction need not even be a result (i.e., based on an underlying stative root). Sentence (143b) can be used to describe a situation where Zhangsan’s laughter evoked a negative emotion in Lisi, causing him to cry.

In summary, the differences between the canonical resultative verb compound and the *de* alternation are not superficial. The first is a complex, composite event describing two causally-connected subevents, whereas the second is a bi-clausal structure describing two events that are more loosely coupled. Head movement in the canonical verbal compound form brings V_1 and V_2 into a configuration so that idiosyncratic meanings can be licensed for particular combinations. This accounts for the difference between literal and phase resultative verb compounds.

3.9 The Syntactic Nature of Event Structure

A major claim of my work is the isomorphism between event structure and syntactic structure: events are composed from primitive functional elements *in the syntax*. Verbs do not introduce complete, well-formed lexical semantic structures into the derivation process; instead, verbal roots represent abstract concepts that acquire meaning from their surrounding syntactic environment. Throughout this work, I have been espousing this view without seriously considering any alternatives.

In this section, however, I will demonstrate that the syntactic approach to event composition better accounts for the empirical facts than the alternative “lexicalist” approach. As a specific case study, I will focus on the causative/inchoative alternation, comparing my approach to that of Levin and Rappaport Hovav (1995). I will demonstrate that evidence in support of their theory does not obviously contradict my own account, and that my analysis better captures many empirical facts, particularly evidence from Mandarin.

Examples of the well-studied causative/inchoative alternation are shown in (144).

- (144) a. John opened the window./The window opened.
 b. Mary shattered the vase./The vase shattered.
 c. The captain sank the battleship./The battleship sank.

Levin and Rappaport Hovav claim that the causative (transitive) alternant is the more basic and that lexical entries of causative verbs directly encode a complex bi-eventive structure. The inchoative form is derived from the causative form via a lexical process that modifies the lexical semantic representation of the verb by suppressing the external argument. My theory makes the opposite claim: causative forms are derived from inchoative forms by the addition of a causing event, which in English is not overtly realized (but is in Mandarin). While I agree that the lexical semantic representation of a causative verb is bi-eventive, I argue that event structure is constructed syntactically, not directly encoded in a verb’s “lexical entry”. My approach denies the existence of purely lexical processes.

To start, I will describe Levin and Rappaport Hovav’s proposal in greater detail. They claim that the lexical entry of *break* is the following:

- (145) *break*: [[*x* DO-SOMETHING] CAUSE [*y* BECOME *BROKEN*]]
 (Levin and Rappaport Hovav, 1995:108)

Verbs directly lexicalize complex event representations and these structures are directly introduced in the syntax; see also (Rappaport Hovav and Levin, 1998). That is, the base form of *break* is a causative accomplishment—to *break* implicates an agent participating in an unspecified activity that brings about a change of state where an entity becomes broken. To derive the inchoative (intransitive) variant, Levin and Rappaport Hovav (1995:106-110) introduce a lexical process of “decausativization” through which the external argument is “absorbed”, and therefore remains unexpressed. They claim that this phenomenon is licensed by semantic features on the verb: decausativization is possible only when the nature of the causing event can be left unspecified. More specifically, the external argument can remain unexpressed when the event denoted by the verb can be conceived of as occurring spontaneously. Schematically, this process is shown below:

- (146) Intransitive *break*
- | | | |
|--------------------|---|--------------|
| LSR | [[<i>x</i> DO-SOMETHING] CAUSE [<i>y</i> BECOME <i>BROKEN</i>]] | |
| | ↓ | |
| Lexical binding | ∅ | |
| Linking rules | | ↓ |
| Argument structure | | < <i>y</i> > |

- (147) Transitive *break*
- | | | |
|--------------------|---|--------------|
| LSR | [[<i>x</i> DO-SOMETHING] CAUSE [<i>y</i> BECOME <i>BROKEN</i>]] | |
| Linking rules | ↓ | ↓ |
| Argument structure | <i>x</i> | < <i>y</i> > |

My approach differs from Levin and Rappaport Hovav’s theory in two important ways: First, I claim that events are compositionally constructed via syntactic processes—verbs do not encode complex event structures, but are merely roots that

combine with various functional elements, which license the relevant eventive interpretations. Second, the inchoative alternant is the more basic form—the causative (transitive) variant is derived from the inchoative by the addition of a causing subevent. This is shown below:

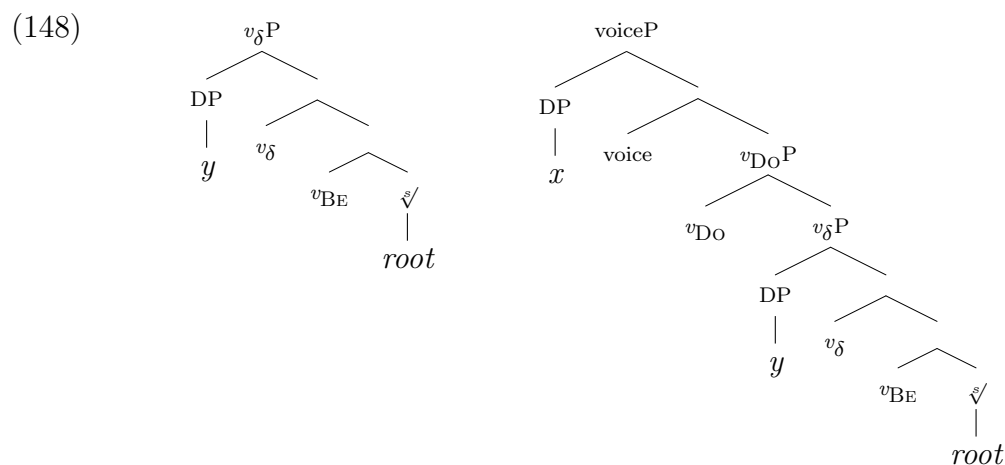

In the following sections, I will attempt to argue that my theory better captures the relevant generalizations regarding this alternation and better accounts for the empirical facts. The argument will proceed in two steps: first, Levin and Rappaport Hovav’s evidence for suggesting that the causative is the more basic form will be carefully reconsidered and refuted. Then, I will present evidence from Mandarin Chinese where their theory has difficulties, and in some cases, makes the wrong predictions.

3.9.1 Deriving Inchoatives from Causatives

Levin and Rappaport Hovav present four pieces of evidence supporting the claim that the causative alternant is more basic. I will examine each piece of evidence in detail and show that the conclusions drawn by Levin and Rappaport Hovav are not necessarily warranted; see (Pylkkänen, 2002) for similar arguments.

In causative/inchoative alternating pairs, it is a generally accepted fact that the object of the causative form and the subject of the inchoative form bear the same semantic relationship to the verb (for convenience, I will refer to this role as the theme). Levin and Rappaport Hovav observe, however, that the selectional restrictions on the theme are not identical in both forms—selectional restrictions on the theme in the intransitive form are tighter than in the transitive form:

- (149) a. Antonia broke the vase/the window/the bowl/the radio/the toaster.
 b. The vase/the window/the bowl/the radio/the toaster broke.
 (Levin and Rappaport Hovav, 1995:85)

- (150) a. He broke his promise/the contract/the world record.
 b. *His promise/the contract/the world record broke.
 (Levin and Rappaport Hovav, 1995:85)

They note that the set of possible themes for the intransitive use of a verb is a subset of the set of possible themes for the transitive use of the same verb. From this, Levin and Rappaport Hovav conclude that the causative form is more basic:

- (151) We assume that the basic use of the verb will impose less stringent restrictions on its arguments ... the use with the looser selectional restrictions, if there is one, will be basic. *We do not make the alternative assumption ... since then it would not be easy to derive the variant with the looser restrictions in a plausible way.* (emphasis mine)
(Levin and Rappaport Hovav, 1995:86)

Their reasoning can be illustrated as follows: the base causative form x imposes selectional restrictions U on its theme. Deriving the inchoative form is a morphological process involving a morpheme α (phonetically empty in English), which contributes its own selectional restrictions V . Thus, the inchoative form $x + \alpha$ should impose selectional restrictions $U \cap V$ on its theme. As a result, the set of possible themes available in the inchoative alternant should be a subset of the themes available in the causative alternant. This does appear to be consistent with the facts observed in English.

I believe, however, that this is not the only plausible explanation, and that Levin and Rappaport Hovav's conclusions are not necessarily warranted. The crucial property relevant for the difference in selectional restrictions between the causative and the inchoative is, as they themselves point out, the spontaneity of an event—the extent to which a causing event can be left completely unspecified. Breaking a promise or a world record is necessarily an agentive activity, which naturally requires an explicit causing activity. Breaking a vase or a radio, on the other hand, could happen spontaneously—the vase being perilously balanced on the edge of a table or a short circuit occurring inside the radio. Given this property, it is entirely conceivable that the causative form of these change of state verbs is derived from the inchoative. The selectional restrictions on the theme in the inchoative form is tighter *because* the cause is unspecified, which renders the sentences anomalous for a certain class of events. Suppose that inchoative verbs do not form a homogeneous group, but can be divided based on this spontaneity feature: those verbs that describe spontaneous events can appear freely in the inchoative form, and those verbs that describe non-spontaneous events can only appear with a causing event (“on top” of the inchoative core). This account predicts exactly the same pattern of selectional restrictions observed in English.

Levin and Rappaport Hovav's second argument stems from an observation made by Chierchia (1989), who points out that unaccusative verbs tend to have “unstable” valency—“[t]hey tend to oscillate in valence from transitive to intransitive and vice versa, both diachronically and across dialects” (Chierchia, 1989:23). The example cited by Levin and Rappaport Hovav is *deteriorate*: while it is generally used intransitively, “Over the years the roof deteriorated”, a transitive use is attested as well, “The pine needles were deteriorating the roof”. This evidence, however, does not provide any hints on the direction of the derivation. If the causative form of *deteriorate* is indeed more basic, then why is the transitive alternant so rare?

The third argument presented by Levin and Rappaport Hovav concerns the morphological relationship between causative and inchoative forms. In Slavic languages, for example, the intransitive form appears to be morphologically derived from the transitive form by employing a reflexive clitic (for example, *-sja* in Russian, *się* in Polish). The following examples in Polish are taken from (Piñón, 2001):

- (152) a. *Rebecca złamała ołówek.*
 Rebecca broke pencil
 ‘Rebecca broke the pencil.’
 b. *Ołówek złamała się.*
 pencil broke REFL
 ‘The pencil broke.’
- (153) a. *Maria otworzyła drzwi.*
 Maria opened door
 ‘Rebecca broke the pencil.’
 b. *Drzwi otworzyła się.*
 door opened REFL
 ‘The door opened.’

French and Hebrew also behave in a similar manner, where the intransitive form is more morphologically complex than the transitive form. Levin and Rappaport Hovav cite a survey by Nedjalkov (1969) which closely examines this phenomenon cross-linguistically. For the verb *break*, the intransitive form is morphologically more complex than the transitive form in twenty-two out of the sixty languages surveyed, less complex in nineteen of the sixty languages, and the same in the other nineteen. Only roughly a third of languages surveyed supports Levin and Rappaport Hovav’s claim, but yet they argue it to be the base case. Haspelmath (1993) conducted a similar cross-linguistic survey of causative/inchoative pairs and arrives at essentially the same conclusion. For languages such as Khalka Mongolian, Hindi/Urdu, and Turkish, for example, the strong tendency is to derive causatives from inchoatives. The follow examples are in Khalka Mongolian:

- (154) *Inchoative* *Causative*
 ser-ex ser-e-ex ‘to wake up’
 ongoj-x onjog-lg-ox ‘open’
 xat-ax xat-a-ax ‘dry’

Haspelmath identifies another pattern of morphological derivation (what he calls *equipollent alternations*), where both the causative and inchoative alternants appear to be derived from a common stem (and neither appears to be derived from the other). Hungarian typifies this pattern (examples from Piñón, 2001):

- (155) a. *Rebecca felébresztette a gyereket*
 Rebecca woke.up the child
 ‘Rebecca woke up the child.’

- b. *A gyerek felébredt*
 the child woke.up
 ‘The child woke up.’
- (156) a. *Maria kinyitotta az ajtót*
 Maria opened the door
 ‘Maria opened the door.’
- b. *Az ajtó kinyílt*
 the door opened
 ‘The door opened.’

The only conclusion that can be drawn from this array of facts is that surface morphology cannot be taken at face value. However, a more detailed explanation of these different patterns of morphological derivations will be saved for future work. As a side note, Pesetsky (1995) argues that for alternating pairs involving reflexive clitics (in such languages as Russian or French), the direction of derivation proceeds from reflexive to non-reflexive. That is, the non-reflexive verb is the zero-derived causative of the reflexive verb—the relevant roots are inherently reflexive. He cites a wealth of evidence supporting this claim and provides an explanation as to why this might be so, which I do not repeat here.

Levin and Rappaport Hovav’s final bit of evidence comes from the interaction of the adverbial *by itself* with the intransitive alternants:

- (157) a. The plate broke by itself.
 b. The door opened by itself.
- (158) a. Mary danced by herself.
 b. John ran by himself.

In English, the adverbial *by itself* is ambiguous between “alone” and “without outside help”. The latter reading is available for inchoative sentences because the adverbial picks out the underlying cause. For unergatives, on the other hand, only the “alone” reading is available. Argues Levin and Rappaport Hovav:

- (159) This adverbial [*by itself*] appears to be modifying a cause, which, given its anaphoric nature, it identifies as the theme argument itself.
 (Levin and Rappaport Hovav, 1995:89)

This, however, cannot literally be true, because it would imply the following:

- (160) a. ??The plate broke the plate.
 b. ??The door opened the door.

Regardless of what the anaphoric relationship between the adverbial and the underlying cause is, data from Japanese contradicts this claim. Pytkänen (2002) discusses adversity causatives in Japanese, which can be independently shown to implicitly encode a cause, but yet are incompatible with *katteni* ‘by oneself’.

After carefully considering the evidence Levin and Rappaport Hovav cite in favor of deriving the intransitive form of change of state verbs from the transitive form via a process of “decausativization”, it can be seen that their conclusions are not necessarily warranted. These facts do not outright contradict any aspect of my syntactic approach to event composition. In the next section, I will argue that my framework better accounts for Mandarin RVCs than lexicalist theories.

3.9.2 Verbal Compounds in Mandarin

Rappaport Hovav and Levin’s (1998) theory of event templates, a more refined analysis of the material presented in (Levin and Rappaport Hovav, 1995), has difficulty accounting for resultative verb compounds in Mandarin. In these constructions, V_2 describes a result, while V_1 describes the activity that brings about this result.

Consider a verb such as *sui₄* ‘shatter’ in Mandarin. Rappaport Hovav and Levin’s theory would contend that the lexical entry for this prototypical change of state verb has the following structure:

- (161) *sui₄* ‘shatter’ =
 [[x ACT_{<UNDEF>}] CAUSE [BECOME [x <SHATTERED>]]]

The *idiosyncratic* component of meaning is named by constants (i.e., open-class items) in angle brackets. The rest of the representation consists of parts drawn from a small, fixed inventory of event templates, representing the *structural* component of meaning. This representation predicts that *sui₄* ‘shatter’ can be used transitively, which is not the case. Mandarin speakers must use a resultative verb compound in order to express the causative sense of shatter:

- (162) a. *bo₁ li₂ sui₄ le₅*
 glass shatter LE
 ‘The glass shattered.’
- b. *??Zhang₁ san₁ sui₄ le₅ bo₁ li₂*
 Zhangsan shatter LE glass
 intended: ‘Zhangsan shattered the glass.’
- c. *Zhang₁ san₁ da₃ sui₄ le₅ bo₁ li₂*
 Zhangsan hit shatter LE glass
 ‘Zhangsan shattered the glass.’

How can Levin and Rappaport Hovav’s theory account for the derivation of Mandarin RVCs such as *da₃ sui₄* ‘hit shatter’? What would the lexical semantic representation of *da₃* ‘hit’ look like? There are two alternatives:

- (163) Option 1: da_3 ‘hit’ = $\langle HIT \rangle$
 Option 2: da_3 ‘hit’ = [x ACT $_{\langle HIT \rangle}$]

One possibility is that da_3 ‘hit’ merely encodes the idiosyncratic component of meaning (i.e., a constant), without an associated event template. This, however, cannot be the case because da_3 ‘hit’ itself can be used as a main verb:

- (164) $Zhang_1 san_1 da_3 le_5 bo_1 li_2$
 Zhangsan hit LE glass
 ‘Zhangsan hit the glass.’

The other option is to claim that da_3 ‘hit’ is associated with its own event template and constant. The derivation of the resultative verb compound, therefore, involves a (presumably lexical) process by which the argument structure of the individual verbs are “fused”. Since the number of total arguments contributed by both verbs exceeds the number of arguments typically expressed by the RVC, the challenge of such a theory is to explain the process by which some arguments are suppressed or merged with other arguments. Y. Li (1990) develops exactly this type of theory, which attempts to predict the transitivity of the entire compound from the transitivity of the component verbs. C.-R. Huang and F.-W. Lin (1992) show, however, that this approach is not tenable (see also Cheng and Huang, 1994). As an example, regardless of the transitivity of the first verb, the resulting verbal compound may itself be transitive or intransitive. For more discussions and problems with this lexical approach, see (Zou, 1994). In addition, Y. Li’s theoretical claim that the external argument of the first verb is always expressed would predict the ungrammaticality of the non-agentive, causative RVC construction, which is perfectly acceptable:

- (165) $na_4 bei_1 jiu_3 he_1 zui_4 le_5 Zhang_1 san_1$
 that glass wine drink drunk CL Zhangsan
 ‘That glass of wine got Zhangsan drunk (from drinking it).’

To Y. Li, the above example is an instance of “inverse theta-role assignment”, whereby the thematic hierarchy is violated. Typically, the agent, being the most prominent role, is linked to the subject. Obviously, this is not the case for Mandarin RVCs such as the one above.

Y. Li (1995; 1999) has subsequently revised his lexicalist theory to account for these facts. In the most recent theory, he argues that *de* resultatives are formed in the syntax, but he maintains that verbal compounds are lexical in nature—thus advocating a two-layer model of grammar. In order to account for inverse theta-assignment, two separate levels of mappings are proposed: one in the lexicon, which “gathers” the thematic roles of the individual verbs, and one in the syntax, which actually assigns thematic roles of the compounds to positions in the syntactic structure. The primary mechanism driving the formation of verbal compounds is Higginbotham’s (1985) process of theta-identification, whereby multiple theta-roles (from different verbs) can be assigned to the same DP. Nishiyama (1998) argues, however, that there is no principled way to tell when theta-identification will occur, and why.

In my theory, thematic roles are an epiphenomenon; specific structural configurations are interpreted in a semantically meaningful way, giving rise to the appearance of homogeneous role labels. I deny the independent existence of thematic roles, but rather reduce them to structural positions relative to verbalizing heads. While Y. Li's algorithm does appear to account for inverse theta-role assignment, there remains a question of its necessity. One major contribution of his theory is the ability to account for the three-way ambiguity with *zhui₁ lei₄* 'chase tired', while explaining the unavailability of a fourth reading. However, as I have shown at the end of Section 3.7, my theory offers a very natural explanation of the different readings within a uniform syntactic framework. A theory that can account for the empirical facts with a common substrate and a uniform set of mechanisms is preferable to an analysis that posits multiple independent levels of representation (lexical and syntactic). A primary advantage of my theory is the grounding of argument structure in well-known syntactic principles.

Any theory of argument structure that posits an independent level of event representation must also include a component of grammar that maps argument positions in the event representation to positions in the syntactic structure. This is generally known as a linking theory, the two most popular forms of which involve thematic hierarchies and linking rules. In a thematic hierarchy, semantic roles (that is, labels associated with argument structure positions) are arranged hierarchically so that the most prominent role is assigned the highest syntactic position (subject), the next most prominent role the next highest syntactic position, and so on (see Section 1.1.1 for more details). A linking theory based on rules consists of a set of partially or totally ordered rules that apply successively to map semantic arguments to syntactic arguments. As a concrete example, Levin and Rappaport Hovav (1995) defend the following rules (repeated from Section 1.1.4):

- (166) a. *Immediate Cause Linking Rule.* The argument of a verb that denotes the immediate cause of the eventuality described by that verb is its external argument.
(Levin and Rappaport Hovav, 1995:135)
- b. *Directed Change Linking Rule.* The argument of a verb that corresponds to the entity undergoing the directed change described by that verb is its internal argument.
(Levin and Rappaport Hovav, 1995:146)
- c. *Existence Linking Rule.* The argument of a verb whose existence is asserted or denied is its direct internal argument.
(Levin and Rappaport Hovav, 1995:153)
- d. *Default Linking Rule.* An argument of a verb that does not fall under the scope of any of the other linking rules is its direct internal argument
(Levin and Rappaport Hovav, 1995:154)

Levin and Rappaport Hovav offer detailed arguments for the validity of these linking rules in English, given their particular lexical semantic representations. Although

these rules do appear to capture important generalizations about the realization of arguments, one must question the necessity of all this machinery. By claiming that event structure *is* syntactic structure, my theory has eliminated the need for an independent representation and reduced linking rules to well-known and well-studied syntactic phenomena (e.g., control and head movement). The primary job of a linking theory is to bring different levels of representation “into alignment”; positing an isomorphism between the two structures, as I have, dramatically simplifies the structure of the grammar. Yet, my theory does not sacrifice coverage of empirical facts, and as I have shown, better accounts for the data in some cases. All things being equal, Occam’s Razor dictates that my simpler syntactic explanation be preferred over a more complex lexicalist one.

3.10 Comparison with Other Approaches

Having argued that a syntactic approach to argument structure and event composition is superior to one that posits independent lexical semantic representations and lexical processes, I will proceed to differentiate my syntactic theory from similar accounts by others. In particular, I will examine Sybesma’s (1999) detailed small clause treatment of Mandarin resultatives and a number of other accounts based on a stacked VP structure, for example, (Collins, 1997; Nishiyama, 1998; Lin, 2001; Zhang, 2001b; Ramchand, 2003).

Here, I will first examine Huang’s (1992) account of RVCs, which does not fit neatly under either a small clause or a stacked VP analysis. In his view, Mandarin resultative verb compounds are instances of complex predicates involving the agglomeration of two separate verbal elements (and PRO). To Huang, RVC formation is a process whereby V_1 and V_2 are re-analyzed as a V^0 , i.e., a lexical compound:

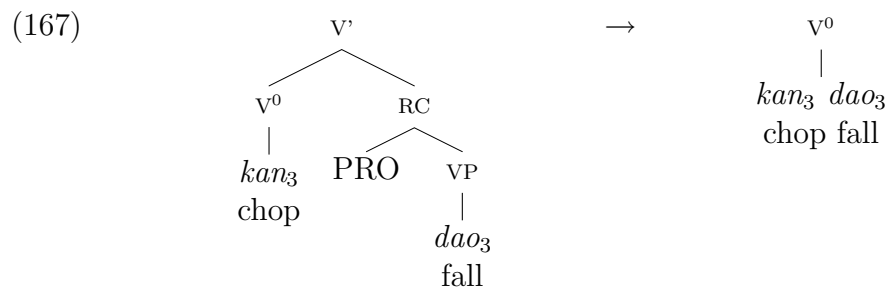

Although fragments of my proposed structures look similar to the complex predicate on the left, I do not maintain a distinction between the lexical and syntactic levels. I provide detailed analyses for a broader range of Mandarin RVCs, and also have shown earlier that the division of lexical and syntactic processes is not necessary to account for the range of variations observed in Mandarin resultatives.

Furthermore, by viewing all V_1V_2 combinations as complex predicates, Huang’s theory is unable to account for the selected/non-selected distinction. Since the RVC is treated as a single lexical item, the presence or absence of a semantic relation between V_1 and the direct object cannot be syntactically captured. Recall that in my

system, a non-selected object in a resultative verb compound is licensed not by v_{Do} , but rather v_s . I have shown in this chapter that the select/non-selected distinction is a syntactically relevant one, and I will present additional evidence supporting this claim in the next section.

3.10.1 The Small Clause Analysis

An analysis of Mandarin resultative verb compounds based on small clauses has been developed in depth by Sybesma (1997; 1999), based on Hoekstra's (1988; 1992) small clause analysis of resultative constructions in other languages. Although I have already argued against such an approach in Section 3.4, and a number of inadequacies have been pointed out by other linguists (Carrier and Randall, 1992), it is nevertheless worthwhile to examine Sybesma's specific instantiation of the general approach in greater detail.

Sybesma distinguishes between three types of resultative verb compounds: intransitive, transitive, and causative. An example of each type is given below, adapted from (Sybesma, 1999:17):

- (168) a. *Zhang₁san₁ de₅ yang₃jing₁ zhui₄ hong₂ le₅*
 Zhangsan DE eye drunk red LE
 'Zhangsan's eyes got red from being drunk.' (intransitive)
- b. *Zhang₁san₁ zhui₄ hong₂ le₅ ta₁ de₅ yang₃jing₁*
 Zhangsan drunk red LE he DE eye
 'Zhangsan got his eyes red from being drunk.' (transitive)
- c. *zhe₄ ping₂ jiu₃ zhui₄ hong₂ le₅ Zhang₁san₁ de₅ yang₃jing₁*
 this bottle wine drunk red LE Zhangsan DE eye
 'This bottle of wine got Zhangsan's eyes red from being drunk.'
 (causative)

To the above three types of resultatives, Sybesma assigns the following structures:

- (169) a. Transitive result structure
 NP [_{VP} V [_{SC} NP XP]]
- b. Intransitive result structure
 e [_{VP} V [_{SC} NP XP]]
- c. Causative resultative
 NP CAUS [_{VP} V [_{SC} NP XP]]

The basic idea behind the approach is that the secondary predicate and its subject form a small clause that together serves as the complement of the main verb. As previously discussed, this analysis does not distinguish between cases where the object of the compound is selected for by V_1 and cases where it is not (the ECM type). According to the theory, the semantic relation (or lack thereof) between the object and V_1 is inferred from real-world knowledge. As I have shown in Section 3.4, this

account overgenerates interpretations that do not exist, and incorrectly predicts a number of impossible RVCs.

Additional evidence from Korean suggests that selected and non-selected resultatives do not form a homogenous category. Subjects of the secondary predication that are also arguments of the matrix verb appear in the accusative, while non-selected arguments appear in the nominative; examples are from (Wechsler and Noh, 2001), but see also (Kim and Maling, 1997):

- (170) a. *Mary-nun kumsok-ul napcakha-key twutulki-ess-ta*
 Mary-TOP metal-ACC flat-COMP hammer-PST-DEC
 ‘Mary hammered the metal flat.’
- b. *Tom-un Mary-ka camtul-key nolayha-yess-ta*
 Tom-TOP Mary-NOM sleep-COMP sing-PST-DEC
 ‘Tom sang Mary to sleep.’

The suffix particle *-key*, glossed as a complementizer, is broadly used in Korean to mark secondary predicates, subordinate clauses, and adverbs. The differences in case markings suggest that selected and non-selected resultatives should not be treated uniformly.

The implicit assumption behind the small clause analysis of resultatives is that they represent a special case of the broader range of ECM constructions. However, there is evidence from Kannada that resultatives must be syntactically distinguished from both ECM constructions and simple transitives (Lidz and Williams, 2002). Both ECM constructions and simple transitives allow verbal reflexive marking (VRM) when reflexive, but resultatives do not. Consider the following ECM (171a) and simple sentence (171b), from (Lidz and Williams, 2002).

- (171) a. *Hari tann -annu puNyavantanendu nambi -koLL -utt -aane*
 Hari self -ACC wealthy believe -VRM -NPAST -3SGM
 ‘Hari believes himself to be wealthy.’
- a. *Hari tann -annu hogaLi -koLL -utt -aane*
 Hari self -ACC praise -VRM -NPAST -3SGM
 ‘Hari praises himself.’

In resultatives, the verbal reflexive marking is ungrammatical, both for cases where the object is selected for, but also in cases where the object is not selected for; examples also from (Lidz and Williams, 2002):

- (172) a. **Hari tann -annu chappatey -aag -i taTTi -koND*
 Hari self -ACC flat -be(come) -PP hammer -VRM.PST
 -a
 -3SGM
 intended: ‘Hari hammered himself flat.’

- a. **Hari tann -age keTTad -aag -i nakki -koND -a*
 Hari self -DAT bad -be(come) -PP laugh -VRM.PST -3SGM
 intended: ‘Hari laughed himself hoarse.’

The grammatical forms of the above resultatives employ only the anaphoric pronoun *tann*:

- (173) a. *Hari tann -annu chappatey -aag -i taTT -id -a*
 Hari self -ACC flat -be(come) -PP hammer -PST -3SGM
 ‘Hari hammered himself flat.’
 a. *Hari tann -age keTTad -aag -i nakk -id -a*
 Hari self -DAT bad -be(come) -PP laugh -PST -3SGM
 ‘Hari laughed himself hoarse.’

This syntactic evidence suggests that resultatives behave quite differently from ordinary ECM constructions, and cannot be analyzed in the same way.

An more controversial proposal in Sybesma’s theory is the uniform treatment of reduced RVCs and subject-control RVCs, both of which are intransitive in their surface form. He argues that (174a) and (174b) have the analyses in (175a) and (175b), respectively.

- (174) a. *shou₃pa₄ ku₁ shi₁ le₅*
 handkerchief cry wet LE
 ‘The handkerchief got wet from crying.’
 b. *Zhang₁san₁ ku₁ lei₄ le₅*
 Zhangsan cry tired LE
 ‘Zhangsan cried himself tired.’

- (175) a. *e ku₁ [shou₃pa₄ shi₁ le₅]*
 b. *e ku₁ [Zhang₁san₁ lei₄ le₅]*

According to Sybesma, the semantic relationship between the subject of predication and the outer verb is inferred. Once again, attributing this inference to real-world knowledge leads to overgeneration of impossible verbal compounds, as discussed previously in Section 3.4.

There is additional evidence that the two different types of RVCs represented by (174) do not comprise a homogeneous group. For example, reduced RVCs can be paraphrased by a passive in Mandarin, whereas subject-control RVCs cannot:

- (176) a. *shou₃pa₄ bei₄ ku₁ shi₁ le₅*
 handkerchief BEI cry wet LE
 ‘The handkerchief got wet from crying.’
 b. *Zhang₁san₁ bei₄ ku₁ lei₄ le₅*
 Zhangsan BEI cry tired LE
 ‘Someone’s crying tired out Zhangsan.’

Whereas (176a) and (174a) are near-paraphrases of each other, (176b) means something very different from (174b). Reduced resultatives appear to have some sort of implicit agent, just like passives. A uniform syntactic analysis of reduced and subject-control RVCs cannot capture these differences.

Furthermore, Cheng and Huang (1994) point out that subject-control and reduced RVCs differ in their ability to undergo the non-agentive, causative alternation. Consider the following reduced RVC (177a) and subject-control RVC (177b).

- (177) a. *du₄zi₅ xiao₄ tung₄ le₅*
 belly laugh hurt LE
 ‘(My) belly hurts from laughing.’
- b. *Zhang₁san₁ he₁ zhui₄ le₅*
 Zhangsan drink drunk LE
 ‘Zhangsan drank himself drunk.’

If the unitary analysis is correct, then the resultative verb compounds should be able to acquire the same type of non-agentive, causative external argument. This is simply not the case; (177b) can alternate with a form that contains a generic cause, as in (178b), but (177a) cannot, as shown by the awkwardness of (178a).

- (178) a. *?na₄ jian₄ shi₄/??Li₃si₄ xiao₄ tung₄ le₅ (Zhang₁san₁ de₅) du₄zi₅*
 that CL matter/Lisi laugh hurt LE (Zhangsan DE) belly
 intended: ‘That matter/Lisi cause Zhangsan’s belly to hurt from laughing.’
- b. *na₄ ping₂ jiu₃/Li₃si₄ he₁ zhui₄ le₅ Zhang₁san₁*
 that bottle wine/Lisi drunk fall ASP
 ‘That bottle of wine/Lisi got Zhangsan drunk.’

In Section 1.2.2, I have argued against the encoding of causation as a functional head. Beyond this theoretical objection, Sybesma’s theory predicts a potential ambiguity that does not arise in Mandarin. His basic structures for the transitive and causative resultatives are shown below, repeated from (169):

- (179) a. Transitive result structure
 NP [VP V [SC NP XP]]
- b. Causative resultative
 NP CAUS [VP V [SC NP XP]]

Since CAUS head is not overtly realized¹⁰, Sybesma’s account would predict an ambiguity for some transitive verbal compounds. Consider the following example:

- (180) *Li₃si₄ zhui₄ dao₃ le₅ Zhang₁san₁*
 Lisi drunk fall ASP Zhangsan
 ‘Lisi got Zhangsan so drunk he fell.’

¹⁰but it is a landing site for movement

The only possible interpretation of *Lisi* is as a non-agentive causer (i.e., Sybesma's causative resultative). Why is the transitive interpretation unavailable? One could certainly come up with a plausible real-world scenario: say *Lisi* got drunk, and in his drunk stupor he pushed *Zhangsan* over. There is nothing that blocks this reading in Sybesma's theory, but yet it is not available. Since my theory distinguishes spurious verbal compounds from true resultatives, I can easily account for the absence of this more complex reading. A recognition of different types of verbal roots leads to a better account of resultative constructions in particular and verbal phenomena in general.

For all the reasons presented above, Sybesma's theory of resultative verb compounds in Mandarin is unable to adequately account for many empirical facts. The problems with his particular analysis extend to all accounts of resultative constructions based on small clauses.

3.10.2 Stacked VP Structures

A theory of argument structure based on a more articulated verb phrase is by no means a new development in generative syntax. Over the years, linguists have discovered that the internal structure of the verb phrase is more complex than originally believed. Key developments include: the VP-internal subject hypothesis (Kitagawa, 1986; Kuroda, 1988; Koopman and Sportiche, 1991), whereby the subject of a verb is generated within the verb phrase and then raises to [Spec, TP]; Larson's (1988) VP-shell structure, originally proposed to account for the double object construction, but has since been employed to explain a variety of other verbal phenomena.

In this section, I will examine alternative accounts of Mandarin resultative verb compounds based on stacked VP structures. Consider Collins' analysis of (181), shown in (182), from (Collins, 1997:493):

(181) John watered the tulips flat.

(182)

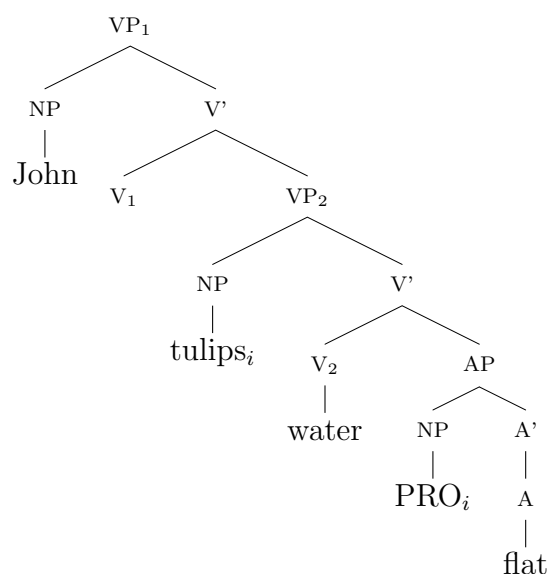

Collins' theory is primarily based on Ewe, a Kwa language spoken in Ghana, Togo, and Benin. Like me, he claims that argument sharing is accomplished through control. Despite an articulated verb phrase structure, Collins' analysis is still "lexicalist" in the sense that the entry of a verb directly encodes the semantics of the event it denotes along with the associated event participants (i.e., the case frame). The account is still based on the idea that the verb needs to discharge a fixed number of theta-roles onto various DPs.

I have argued throughout this thesis that the independent existence of thematic roles is not necessary for a complete theory of argument structure—thematic roles can be reduced to structural configurations with respect to particular functional heads, and hence are epiphenomenal. The key advantage of this approach is a much more transparent syntax-semantics interface that does not require additional stipulations.

There are additional problems with the structures Collins propose. If the structure in (182) represents a resultative construction, then what is the analysis of the corresponding simple sentence? Here are the reasonable possibilities:

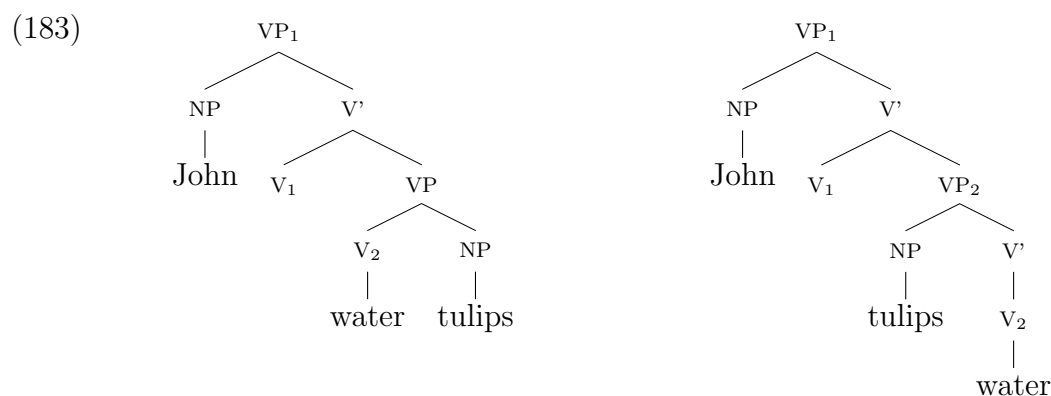

The tree on the left has the problem that the structural relationship between the direct object and the matrix verb in the simple sentence is different from the structural relationship between the same two elements in the resultative construction. As extensively discussed in Section 3.4, there is evidence that this relation should be identical in both cases. This leaves us with the tree on the right. But if that structure is correct for a simple transitive activity, what then would be the analysis for a causative accomplishment? Possible structures are show in (184), but it is unclear how the causative/inchoative alternation could be syntactically captured (and middles and passives, for that matter). In a sense, the verb phrase structures presented by Collins are not sufficiently articulated to make all the grammatically relevant distinctions necessary in a theory of argument structure (without resorting to theta theory).

(184)

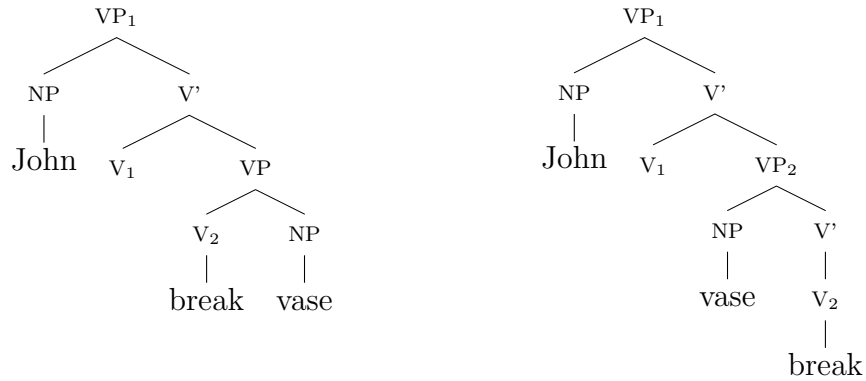

Although stacked VP structures are theoretically motivated and empirically justified, the greatest challenge of such accounts concerns the proper interpretation of the VP layers. Requiring an independent theory of thematic roles partially defeats the point of having more articulated verb phrases to begin with, since one goal of such theories was to better explicate the syntax-semantics interface. As I have shown throughout this work, one key advantage of my theory is that structural relations in the syntax have well-defined correspondences at LF: for example, adjunction between a verbalizing head and a verbal root translates into event modification, the specifier of v_δ contains the entity undergoing the change of state, the specifier of v_{DO} is the affected argument of an activity, etc.

Nishiyama's (1998) work represents another noteworthy attempt at analyzing resultative constructions using stacked VP structures. Although the bulk of the work focuses on resultative verb compounds in Japanese, he extends the analysis to Mandarin RVCs also. In (185), a typical object-control RVC is shown; in (186), a typical unselected RVC. For brevity, only glosses are used.

(185)

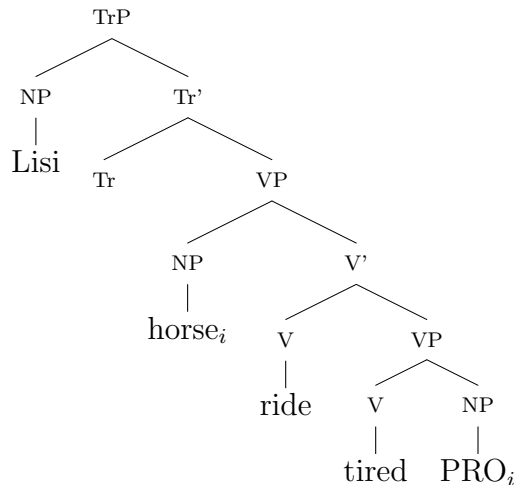

(186)

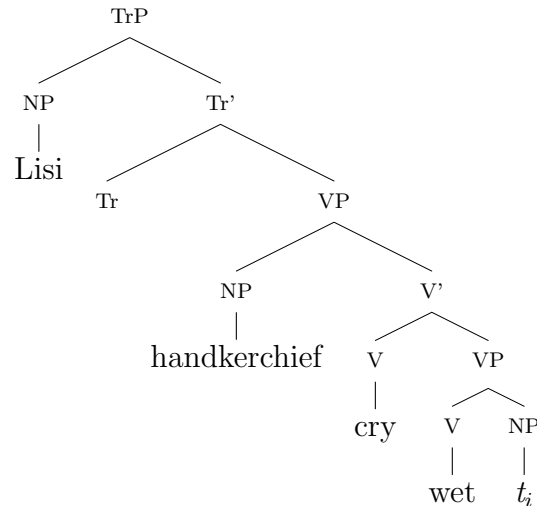

The appearance of PRO in an object position is odd, but Nishiyama (1998:183) adopts the view that PRO can appear in any non-case position. Note that Nishiyama's Transitive Phrase (TrP) is essentially the same as *voice*. Thus, Burzio's Generalization can thus be restated as follows:

(187) *Burzio's Generalization (Modified)*

The object position is a Case position iff the clause contains active Tr.
(Nishiyama, 1998:183)

The claim that PRO appears in non-case positions, however, is simply not true. For example, Icelandic PRO subjects of infinitival clauses are shown to be assigned quirky case (Sigurðsson, 1991). In fact, Hornstein makes the generalization that any language with quirky case will have case-marked PRO (Hornstein, 1990).

Furthermore, Nishiyama's analysis implies that the embedded predicate in (185) is an unaccusative verb, which also isn't true. I have argued at length in Chapter 2 that unaccusatives are derived from underlying stative roots. The stative status of *lei₄* 'tired' is furthermore confirmed by both the contradiction test and the interpretation of the A-not-A construction. Similarly, in (186), Nishiyama claims that *wet* is an unaccusative, which is also not true.

Ramchand's (2001; 2002; 2003) theory of "First Phase Syntax" is a recent account of verbal syntax that, like my theory, attempts to eliminate the notion of thematic roles from the grammar and impose a straightforward correspondence between syntax and semantics. She proposes a tripartite decomposition of event structure, which can be schematically shown as follows:

(188)

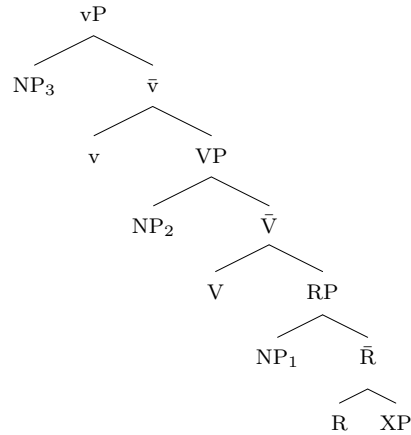

The complete verb phrase contains three different projections, each of which corresponds to a possible subpart of the entire event. vP introduces the causation event and licenses different types of external argument; NP_3 is the “subject of cause”. VP specifies the nature of the change or process and licenses the entity undergoing change or process; NP_2 is the “subject of process”. RP gives the “telos” or “result state” of the event and licenses the entity that comes to hold the result state, NP_1 is the “subject of result”. As a concrete example, consider Ramchand’s analysis of a prototypical causative change of state verb:

(189) x broke y

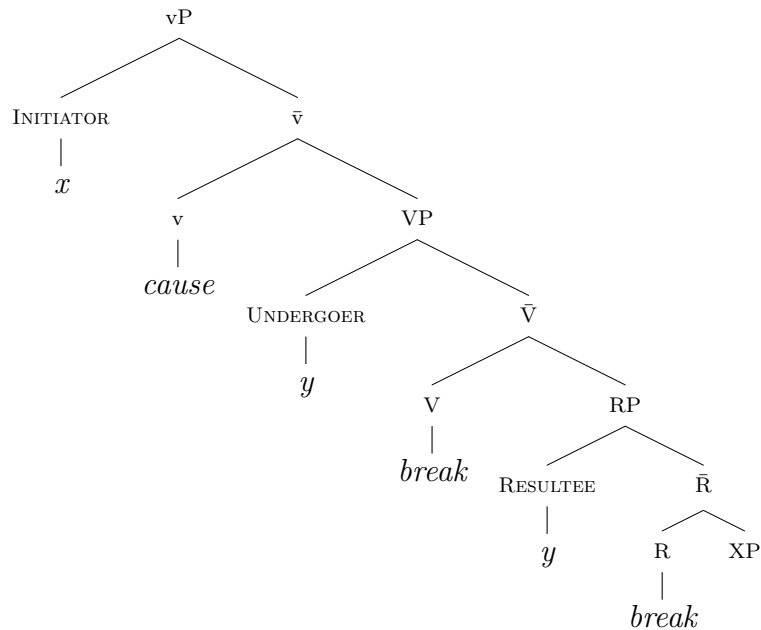

Unlike me, Ramchand does not consider the lexical items that surface as verbs to be abstract categoryless roots devoid of syntactic information. Instead, lexical items in her system are associated with the features $\pm v$, $\pm V$, $\pm R$, that govern their ability to be inserted (and in some cases, multiply inserted) into the various different syntactic contexts. The theoretical implications of this system are unclear at this point.

This difference aside, there exists a relatively straightforward intuitive correspondence between elements in Ramchand's decomposition and my own inventory of verbalizing heads. Her RP is akin to my v_{BE} , her VP is similar to my v_{δ} , and her vP corresponds to v_{Do} (except I further include a *voice* head). In Ramchand's system, secondary predicates in resultative constructions are specified in the XP, as in the following:

(190) *x wipe y clean*

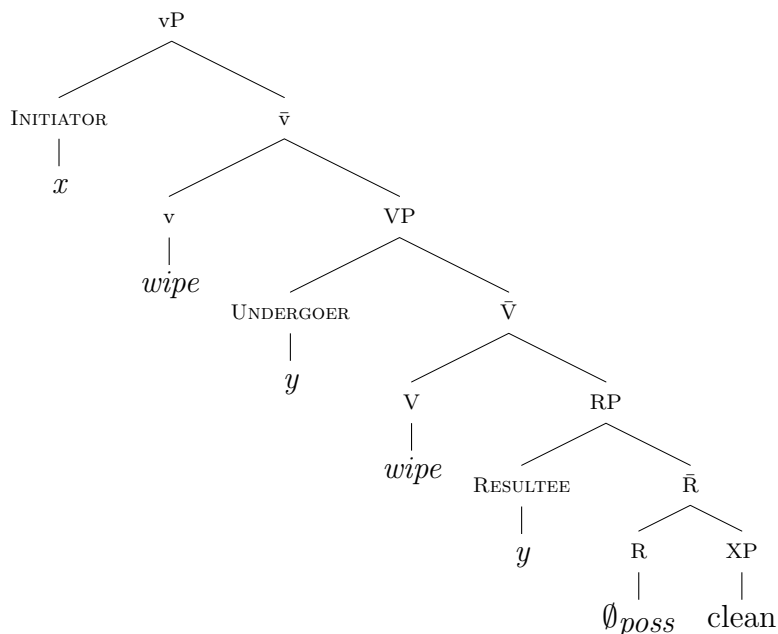

It is unclear how these structures differentiate between selected and non-selected resultatives. By Ramchand's own event composition rules, the semantic relations between v , V , and R do not involve explicit argument sharing. For example, the semantic restriction that x actually comes into contact with y is not encoded in the syntactic structure. Leaving this inference to pragmatics or real-world knowledge, as we have previously seen, overgenerates spurious interpretations.

Ramchand's proposal is interesting in that two separate subject positions are posited for both the change of state and the end state (Spec of VP and RP, respectively). Typically, both positions are linked together, as in the *break* example above. The structure, however, leaves open the possibility that the two subject positions might be filled by different objects. For example, what would prevent ungrammatical sentences such as the following?

- (191) a. *John swept the floor the dust into a pan.
 b. *Mary drank many pints the pub dry.

If the two subject positions are indeed always linked, then why have both in the first place? Furthermore, Ramchand's theory has difficulty accounting for Mandarin resultative verb compounds, since she relegates secondary predicates to the XP without discussing in detail the constraints acting thereon. The result phrase in a

Mandarin RVC is verbal in nature, and should belong in either the V or R position. But if this were the case, then the theory would not have a uniform treatment of resultative constructions cross-linguistically.

To be fair, Ramchand's theory of First Phase Syntax is not fully developed, and this critique is based on a collection of relatively short papers and an incomplete manuscript. Although Ramchand's theory is similar in spirit to mine and accomplishes some of the same goals, there are many implementational details that she has not yet worked out.

Another interesting piece of work is that of T.-H. Lin (2001), who examines light verb syntax in Mandarin. His focus, however, was on the array of phenomena in Chinese known as the unselectiveness of subject and object. Although the spirit of his theory is similar to that of mine, T.-H. Lin never fully specifies an inventory of primitives along with rules and constraints for event composition.

3.11 Conclusion

This chapter presented a thorough analysis of Mandarin resultative verb compounds, highlighting the dimensions of variation that any theory of argument structure must capture. My typological study was followed by a syntactic treatment of Mandarin and English resultatives that successfully accounts for a broad range of empirical facts. I have shown that resultative constructions not only serve as an illuminating probe into the composition of argument structure, but also relate to other aspects of lexical semantics, including middles, causatives, and psych predicates. The higher-level objective of this study, however, is to explicate the processes by which event structure is composed syntactically from a particular set of primitives, and how these processes can be grounded in independently-motivated syntactic principles such as control and movement. I have demonstrated how my account is to be preferred over others based on independent lexical semantic representations, lexical processes, and alternate ways of articulating the verb phrase structure. My theory not only accounts for all the relevant syntactic facts, but also supports transparent interpretation at the syntax-semantics interface. In the next chapter, I will turn my attention to the question of cross-linguistic variation.

Chapter 4

Cross-linguistic Variations

This chapter focuses on cross-linguistic variations in the behavior of Mandarin and English verbs. If both these languages compose verb meanings using the same basic inventory of primitives building blocks and are governed by the same constraints on event composition, why do the surface forms of Mandarin and English verb phrases appear so different? In Chapter 2, I have demonstrated that change of states predicates in Mandarin are constructed from stative verbs. English, in contrast, shows little overt evidence for the regular syntactic processes that produce change of state verbs from underlying stative roots. A successful theory of verbal argument structure must account for these facts, and also identify the cross-linguistic variations that give rise to differences in verbal behavior. As a step towards understanding these variations, I will attempt to answer the following question in this chapter:

- (1) a. If a stative root underlies change of state verbs, why is it not directly “inaccessible” in some languages?
- b. Why are the stative counterparts of many change of state verbs more morphologically complex in English?

Consider the generic structure of a causative change of state sentence, according to the theory of verbal argument structure that I have been espousing:

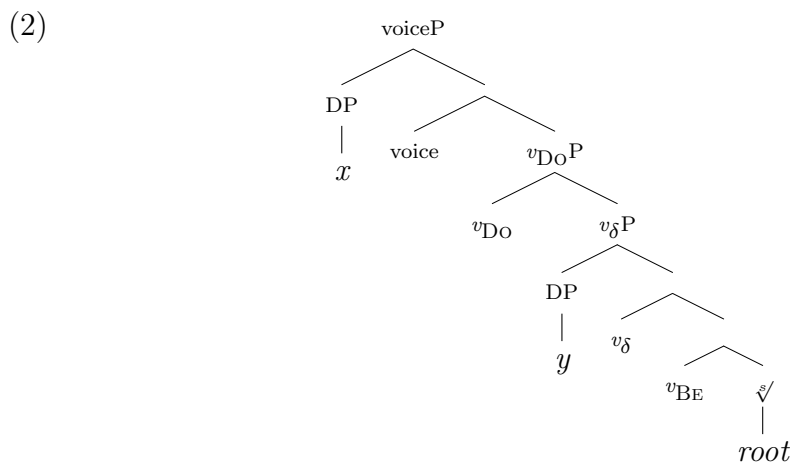

At the innermost core of such a sentence is a stative root licensed by v_{BE} , which describes the final state of the “undergoer”. An inchoativizing head v_{δ} “wraps” this stative root, giving rise to a change of state meaning. The specifier of v_{δ} is the entity undergoing the change of state, typically interpreted as the theme. Above this inchoative core is a causing event, typically a generic activity licensed by v_{DO} , which may or may not be modified by a verbal root (specifying the specific activity). It is understood that the relationship between v_{DO} and the projection headed by v_{δ} is one of causation. Finally, the *voice* head relates the external argument to the causing activity, typically agent or instrument. In this manner, event and argument structure is compositionally built up from primitive facets of meaning.

Naturally, a detailed cross-linguistic exploration of this entire structure is beyond the scope of my work. Instead, I would like to focus on the “inchoative core” of sentences, i.e., from v_{δ} on down. The following sections will argue that Mandarin and English are quite similar at the event structure level, despite differences in the way verbal roots appear in the surface form. I will show that cross-linguistic differences can be captured in terms of a semantic property of the roots, and different ways in which verbalizing heads from Mandarin and English are sensitive to this feature.

4.1 Stative Roots

In its current formulation, my theory of argument structure predicts that states should form the basis of all change of state events, whether states are lexicalized as adjectives, nouns, or verbs. All else being equal, change of state predicates should be at least as morphologically complex as stative forms (allowing for the possibility of zero-derivations). This is indeed the case for languages such as O’odham and Huallaga Quechua, where there is clear morphological evidence for the derivation process (data repeated from Chapter 2):

- (3) O’odham (Hale and Keyser, 1998:92)

<i>Adjective</i>	<i>Inchoative</i>	<i>Causative</i>	
(s-)weg-i	weg-i	weg-i-(ji)d	‘red’
(s-)moik	moik-a	moik-a-(ji)d	‘soft’
(s-)'oam	'oam-a	'oam-a-(ji)d	‘yellow’

- (4) Huallaga Quechua (Weber, 1989)

<i>State</i>	<i>Inchoative</i>	<i>Causative</i>	
qarwash-	qarwash-ta:-	qarwasy-ta:-chi-	‘yellow’
han	han	han	‘above on slope’
hatun	hatun-ya:-	hatun-ya:-chi	‘big’
umasapa-	umasapa-ya:-	umasapa-ya:-chi	‘big headed’

As I have shown in the previous chapters, Mandarin behaves in a similar way. Although v_{δ} is covert, its presence is suggested by the interactions between the perfective

marker *le* and stative verbs. The base form of Mandarin verbs are either activities or states, and other event types (accomplishments and achievements) are derived from these two primitive categories by syntactic processes (as outlined in Chapter 2). The following illustrates the range of stative verbs in Mandarin:

- (5) a. *ni₃ ai₄ ta₁*
 you love her
 ‘You love her.’
- b. *Li₃si₄ hen₃ gao₁xin₄*
 Lisi very happy
 ‘Lisi is very happy.’
- c. *bo₁li₂ sui₄ de₅ man₃ di₄*
 glass shatter DE whole floor
 ‘The glass lies in shattered pieces all over the floor.’

Turning to English, however, we see a more complex picture. Instead of a homogeneous class of stative verbs, English employs a variety of devices to convey states. Compare the following sentences, contrasted with their Mandarin counterparts:

- (6) a. John loves Mary
 b. Sue is happy.
 c. The window is broken.

Although English has an inventory of stative verbs, i.e., *love*, *believe*, *know*, etc., most states are lexicalized as adjectives. To convey certain states, speakers must resort to forms usually known as adjectival passives (Levin and Rappaport Hovav, 1986) or, more specifically, resultative participles (Embick, 2002), which denote the result of an action. These participial forms are derived from change of state verbs, and their underlying states do not appear to be directly “accessible”.

The necessity of employing participial constructions to convey certain states seems to contradict my theory of verbal argument structure. Since I claim that change of states are derived from stative roots, surface forms representing states should be less morphologically complex. Why then, does it appear that *broken*, representing a state, derives from *break*, a verb?

Another interesting issue is whether or not (6c) necessarily implies a prior event. For example, does *broken* always refer to the result of a breaking event? Not necessarily, as it turns out; consider the following:

- (7) a. the broken glass
 b. the broken valley
 c. the broken promise
 d. the broken line

While it would be natural to assume that *the broken glass* refers to the state of affairs after the glass had undergone an event of breaking, the same cannot be said of *the broken valley*, unless it refers to the action of rivers, for example. While a metaphoric interpretation is perhaps plausible for *the broken promise*, the phrase *the broken line* defies such an explanation; no event is implied. A line could be drawn in a broken state, without having undergone any change of state.

These results lead one to believe that the phrases in (7) do not constitute a homogeneous group. More puzzling, however, is the base verb *break*. If the underlying root is stative (that is, $\sqrt{\text{break}}$, best glossed as ‘broken’), as my theory suggests, then why is the basic surface form of the root a change of state verb, and not, say, a stative verb or an adjective? In other words, what accounts for the ungrammaticality of the following structure?

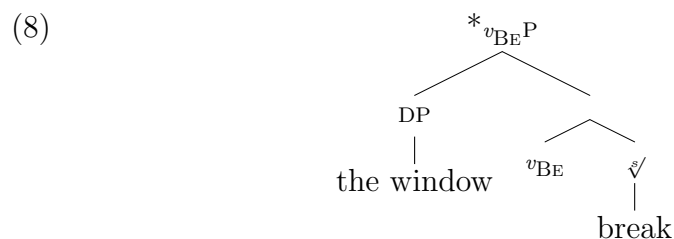

The alleged surface form of the above tree would be:

(9) *The window breaks. (stative, i.e., the window is broken)

This reading is clearly not available in English. In order for my theory to be correct, I must somehow disallow the structure in (8), along with many other verbs in English that denote change of states in their basic surface form, e.g., the class of unaccusative verbs.

The insight I adopt to explain this phenomenon is the *property concept* vs. *result state* dichotomy. Dixon (1982) argues that “certain states, naturally described by adjectives, contrast with states that are the result of some action”. Koontz-Garboden and Levin (2004) show that this semantic property is relevant for the encoding of change of state verbs across languages. Typically, property concepts are lexicalized as adjectives in languages that have such a category, and either as verbs or nouns in languages that do not. Dixon claims that if a language has adjectives, they are usually drawn from the following semantic domains (examples from Koontz-Garboden, 2004):

(10) Property concept classes

- a. Dimension: big, large, little, small, long, short, wide, narrow, thick, fat, thin, deep, shallow (plus a few more)
- b. Physical property: hard, soft, rough, smooth, rough, square, hot, cold, warm, cool, sweet, sour, tart, quiet, loud (plus many more)
- c. Color: black, white, red, green, yellow, blue, purple, . . .

- d. Human and Animal propensity: jealous, happy, kind, clever, generous, gay, cruel (plus many more)
- e. Age: new, young, old, ancient
- f. Value: good, bad, proper, perfect, pure, excellent, fine, fantastic, wonderful, terrible, atrocious, poor, beautiful, ugly, delicious, tasty (plus more)
- g. Speed: fast, quick, slow (plus a few more)

Property concepts represent inherent states of entities, which contrast with result states, which describe the result of some action. In English, it appears that property concepts are encoded as adjectives, while result states surface as change of state verbs in their basic surface forms. I will capture this semantic distinction in the feature \pm property:

- (11) $\sqrt{\text{break}} [-\text{property}] = \text{result state}$
 $\sqrt{\text{flat}} [+ \text{property}] = \text{property concept}$

The difference between Mandarin and English, I suggest, is that verbalizing heads in English are sensitive to this feature, whereas verbalizing heads in Mandarin are not. More specifically, I posit a parameter of v_{δ} that governs the sensitivity of the functional head to the property concept vs. result state distinction. I remain agnostic to the actual mechanism for accomplishing this, but consider this possibility: a [+property] feature needs to be checked off by a corresponding feature on v_{δ} in English, whereas v_{BE} handles this checking in Mandarin. Alternatively, it could be the case that [+property] is somehow uninterpretable at the interfaces in English, but interpretable in Mandarin. Regardless of the technical implementation, the derivation of the tree in (8) would crash in English, resulting in the ungrammaticality of the stative root being directly interpreted as a stative verb.

If the property concept vs. result state distinction is truly a relevant semantic property of stative roots for the purposes of argument realization, then why do closely related pairs of roots exhibit different behavior?

- (12) a. The door is open. (state)
 b. The door opened. (change of state)
- (13) a. The door is closed. (state)
 b. The door closed. (change of state)

It appears that *open* is a property concept, patterning with adjectives such as *dim*, *clear*, *tame*. Verbal forms are derived from these adjectives by a zero affix. On the other hand, *close* seems to be a result state because its basic surface form is a change of state verb, not an adjective or a stative verb. How can we reconcile these difference, given the natural semantic relation between the concept of open and close?

The explanation, I argue, is that the property concept vs. result state distinction is not extra-linguistic in nature, but rather reflects the often idiosyncratic ways in which meanings are packaged into verbal roots. Although the general tendency is that inherent properties of entities appear as property concepts, and the result of events as result states, how abstract concepts are actually represented linguistically may differ from language to language, and even among semantically similar concepts in the same language. Rosen (1984) demonstrates that with respect to unaccusativity, verbs with similar meanings in and across languages may display different syntactic behavior. For example, *die* acts like an unaccusative verb in Italian, but patterns with the unergative verbs in Choctaw. Another often cited example is the contrast between *russare* ‘snore’ and *arrossire* ‘blush’ in Italian (cf. Levin and Rappaport Hovav, 1995): although both fall under the semantic class of “verbs of bodily processes”, their syntactic behavior is different. Whereas *russare* ‘snore’ manifests unergative properties, *arrossire* ‘blush’ appears to be unaccusative, better paraphrased as “to become red in color”.

As a result, there is no way to predict *a priori* the actual semantic properties of a verbal root from the real-world concept it denotes, i.e., the distribution of [\pm property] is not entirely predictable on extra-linguistic semantic grounds. However, the generalizations and intuitions behind the property concept vs. result state dichotomy do appear to capture a general cross-linguistic tendency in how real-world meanings are packaged into verbal roots.

4.2 Different Languages, Different Choices

I believe that cross-linguistic differences between the Mandarin and English verbal systems represent merely two points along a spectrum of possibilities for composing verb meanings from the basis set of primitives I have proposed. In short, different languages employ different syntactic devices for distinguishing between the following two structures (and the meanings that they denote):

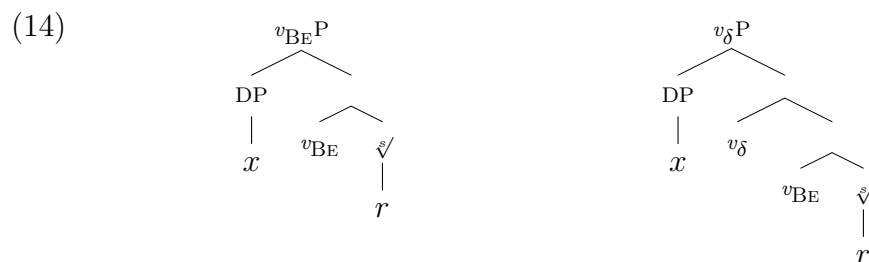

The critical difference between the above two structures is the stative versus inchoative contrast: the tree on the left denotes a state, while the tree on the right denotes a change of state. Since both structures may be derived from the same underlying stative root, a sentence could potentially be ambiguous between two very different meanings. There are, in principle, at least a few devices for resolving this ambiguity:

- (15)
- a. Overtly realize one or both of the verbalizing heads.
 - b. Employ another morpheme that co-occurs with either verbalizing head (i.e., as a marker of either inchoativity or stativity).
 - c. Have different types of stative roots surface as different lexical categories.
 - d. Any combination of the above strategies.

O’odham and Huallaga Quechua, for example, place the burden on (15a), overtly realizing v_δ and v_{DO} as part of productive morphological processes. Mandarin, however, employs a different set of strategies. Although there is no copular construction, and all stative roots surface as verbs, the language does make use of perfective verbal *le*, which co-occurs with stative verbs only in a change of state reading. These three languages demonstrate clear evidence that verb meaning is “built up” from finer-grained semantic components.

English, in contrast, utilizes a different combination of strategies. The functional head v_{BE} is realized as the copula, and v_δ manifests in inchoativizing suffixes such as *-en* (but unlike O’odham or Huallaga Quechua, this process is not fully productive). As I have argued in the previous section, the surface forms of English stative roots depend upon the value of finer-grained semantic features. Property concepts appear as adjectives in their base form, and result state roots are, in essence, bound to a covert v_δ , surfacing as change of state verbs. Finally, many psychological states appear as stative verbs.

The derivation of deadjectival verbs such as *flatten* from the adjective *flat* (property concept root) and the suffix *-en* is syntactic in nature. In the framework of Distributed Morphology (Halle and Marantz, 1993, 1994), upon which my theory of argument structure is grounded, syntax is assumed to be the single generative engine underlying the human language faculty. Furthermore, syntax does not manipulate entire lexical items (i.e., elements with an associated phonological matrix), but rather bundles of abstract features with MERGE and MOVE. Under the hypothesis of “Late Insertion”, vocabulary items are associated with phonological content after the derivation process is complete, at “Spell-Out”.

Given these theoretical assumptions, I claim that the correct representation of sentence (16) is shown in (17).

(16) His face reddened.

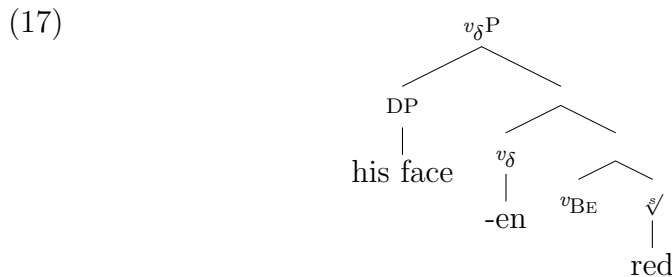

In this case, the *-en* suffix is the overt realization of v_δ . What evidence is there for such an analysis? Consider the alternative: *-en* is a causative change of state suffix (Levin and Rappaport Hovav, 1995); the causative form is directly derived from

the adjective, and then undergoes decausativization to produce the inchoative alternant. As I have argued in Section 3.9, this general paradigm of deriving inchoatives from causatives is untenable; not only is the evidence supporting this account suspect, but empirical facts from Mandarin suggest otherwise. Given the alternatives, I believe that analyzing *-en* as v_δ is the correct choice.

The structure in (17) further undergoes causativization by embedding v_δ P as the complement of v_{Do} ; *voice* introduces the external argument. Incorporation, along the lines of what I have described in Chapter 1, produces the surface form of the sentence. The structure of the transitive use of *red* is shown below:

(18) The sun reddened his face.

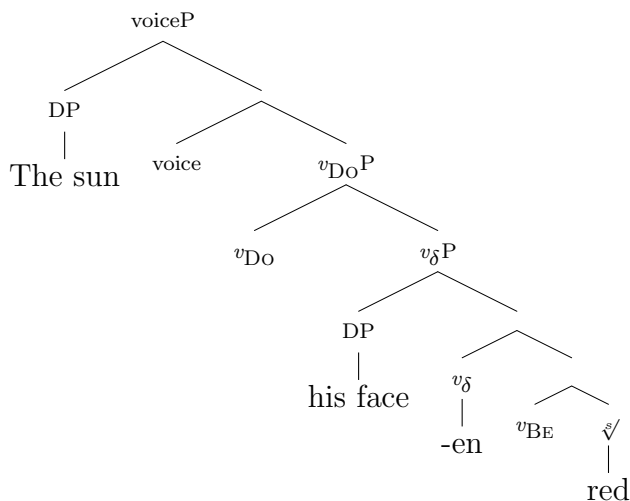

If my analysis of deriving causative verbs from their inchoative counterparts is correct, what explains the ungrammaticality of certain deadjectival verbs in the intransitive frame?

- (19) a. *Gay marriage legalized. (cf. The courts legalized gay marriage.)
 b. *The wild bear tamed. (cf. The trainer tamed the wild animal.)¹

I assume that *-ize* is the overt realization of v_δ in (19a) and that v_δ is not overtly realized in (19b).²

To account for these facts, I would like to once again appeal to the notion of spontaneity (see Section 3.9). Property concepts, like result states, come in both spontaneous and non-spontaneous varieties—a semantic distinction Haspelmath (1993) finds relevant for the encoding of verb meanings cross-linguistically. Non-spontaneous stative roots such as $\surd/legal$, $\surd/tame$, $\surd/italic$, and $\surd/visual$ simply cannot appear without a causing activity licensed by v_{Do} (because they would be semantically anomalous).

¹There does not appear to be any *-en* deadjectival verbs that is grammatical only in the transitive frame.

²As an alternative, one might treat *-ize* as the overt realization of v_{Do} (and v_δ as a zero affix). However, this would predict the grammaticality of “*Gay marriages legal” meaning that gay marriages became legal.

This could be technically implemented by a system of feature checking, whereby an unchecked spontaneity feature causes a derivation to crash, and hence prevents non-spontaneous states from obtaining without an explicit causing activity.

4.3 Resultative Participles in English

Having discussed some theoretical issues regarding the encoding of stative roots in English and Mandarin, I will now proceed to refine my analysis of English resultative participles, extending the insights of Kratzer (2000) and Embick (2002). Consider the following sentences:

- (20) a. The door is open. (stative/adjective)
b. The door is opened. (resultative participle)
c. The door was opened by John. (passive)
- (21) a. The door was built closed. (stative participle)
b. The door is closed. (resultative participle)
c. The door was closed by Mary. (passive)

The examples in (20) show three distinct surface forms of $\surd/open$. The first, (20a), describes a simple state that does not implicate a past event. Since $\surd/open$ is a property concept, i.e., [+property], the stative form is simply an adjective. The second, (20b), also describes a state, but it denotes the state that results from some action, i.e., it presupposes a previous event. This form is generally known as a resultative participle. It is interesting to note that the resultative participle is morphologically identical, but yet semantically distinct from the passive, e.g., (20c), which is eventive, not stative, in nature.

The same three-way distinction is also present for $\surd/close$, but since it is a result state, i.e., [-property], the stative and resultative forms are both participial in nature. Once again, the passive patterns with the participial forms morphologically, although they are obviously distinct semantically. Although *closed* in (21a) and (21b) have identical surface forms, the first usage does not presuppose a closing event, while the second usage does. This parallels a similar distinction noted earlier with *broken*:

- (22) a. the broken line (stative)
b. the broken window. (resultative participle)

The example in (22a) does not describe the result of an event. A broken line is not the result of breaking a solid line; it is a line simply drawn in a “broken” state. On the other hand, (22b) presupposes a breaking event involving a window and denotes the result thereof.

What would the syntactic analyses of the different forms in (20) and (21) look like? Let us start with the root $\surd/open$, a property concept. Since it surfaces as an adjective in its base form, there must be an “adjectivizing” head, which I call *a*, that gives rise to the proper lexical category:

(23) The door is open. (stative)

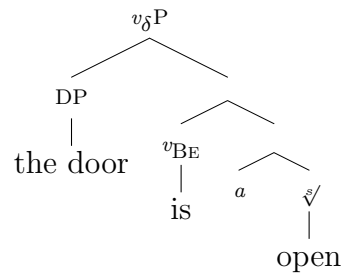

Sentence (20b), in contrast, is a refers to an end state that obtains as the result of some event. The proper representation is the following; see (Kratzer, 2000; Embick, 2002) for similar treatments:

(24) The door is opened. (resultative participle)

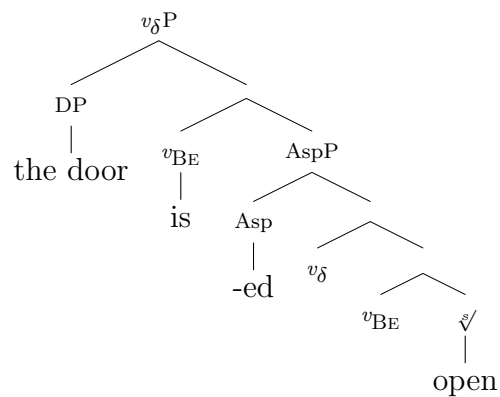

Following Embick (2002), I assume that a functional element takes a change of state (the complex structure involving v_δ , v_{BE} , and the stative root) and “picks out” the end state. Since this projection also stativizes an event, it is likely to be aspectual in nature. There appears to be no evidence for an adjectivizing head a in the structure.

Since I argue that (20b) describes the result of an event (and hence presupposes that event), my analysis predicts that it would be possible to anaphorically refer to this “hidden event”. Indeed, this prediction is borne out:

- (25) a. The door is open. #It happened in an instant/last night.
 b. The door is opened. It happened in an instant/last night.

Given these facts, it appears that resultatives participles based on property concepts are derived from change of state verb forms, which are in turn derived from underlying stative roots. Schematically, this process is as follows:

(26) property concept root \rightarrow change of state verb \rightarrow resultative participle

For property concepts, the corresponding change of state verb is derived with suffixes such as *-en*, *-ize*, *-ify*, and \emptyset , which are different surface realizations of v_δ . The suffix *-ed* then transforms the change of state verb into the resultative participial form. More examples of these derivations are listed below:

(27)	property concept	change of state	resultative participle
	√/flat	flatten	flattened
	√/wide	widen	widened
	√/liquid	liquidify	liquidified
	√/modern	modernize	modernized
	√/dim	dim	dimmed
	√/clear	clear	cleared

Turning to result states, e.g., the examples in (21), we see a slightly different situation. As I have previously discussed, result states in English appear as change of state verbs in their base form (as opposed to adjectives). This can be attributed to the interactions between verbalizing heads and a semantic feature of the root, subjected to parametric variations cross-linguistically. Due to this, the stative forms, e.g., (21a), and resultative forms, e.g., (21b), are both participles in English. The two different interpretations arise from either the presence of absence of v_δ , which licenses the change of state.

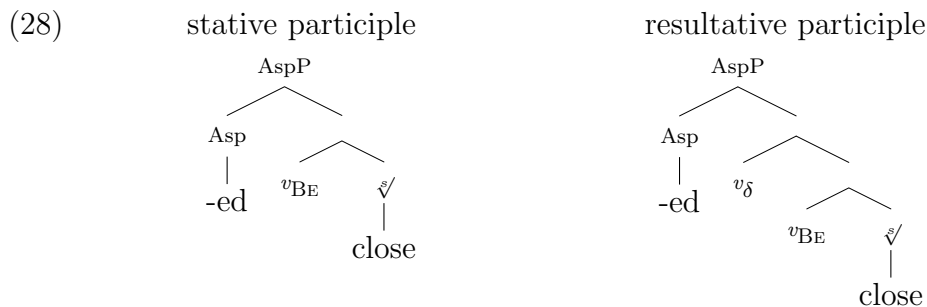

Despite identical surface forms, the stative and resultative participles are built through different processes. Resultative participles are created from change of state verbs with the addition of an aspectual projection, just as in the case with property concepts. The stative form, on the other hand, derives directly from a combination of v_{BE} and the result state root.³ This can be shown as follows:

- (29) result state root → change of state verb → resultative participle
 result state root → stative participle

More examples of resultative participles and their underlying forms are shown below in (30). The little overt morphology available in English appears to be consistent with my account (the suffixes *-en* and *-ed* appear to be allomorphs, also consistent with participial morphology):

(30)	result state	change of state	resultative participle
	√/break	break	broken
	√/freeze	freeze	frozen
	√/sink	sink	sunken
	√/shatter	shatter	shattered
	√/melt	melt	melted

³Embedded under an aspectual projection, a result state root can appear without a v_δ .

It has not escaped my attention, and also the attention of many linguists, that the surface form of resultative participles in English are usually identical to the eventive passive forms and other participial constructions (e.g., past participles in perfects).⁴ The relationship between these different forms, however, is an issue that I will leave for future study.

4.4 Conclusion

In this chapter, I have examined in greater detail one small component of event structure, namely, the “inchoative core” of a sentence. The primary goal was to reduce differences between Mandarin and English to parametric variations in the elements that participate in the syntactic derivation, thus preserving the overall structure of the underlying theory. Specifically, I examined the relevance of the property concept vs. result state distinction in the encoding of stative roots. I concluded that cross-linguistic differences between Mandarin and English can be boiled down to the sensitivity of verbalizing heads to this semantic feature. My theory of verbal argument structure can not only capture a wide range of verbal phenomena within a single language, as I have demonstrated in the previous chapters, but can also capture generalizations across languages that look superficially different.

⁴Interestingly, Embick (2002) notes the following exceptions: *rotten* vs. *rotted*, *shaven* vs. *shaved*, *blessèd* vs. *blessed*.

Chapter 5

Concluding Remarks

Anyone engaged in the study of human languages is immediately struck by two amazing facts. The first concerns the diversity of language, and the second its ubiquity. I am often awe-struck by the range of grammatical patterns exhibited by various languages of the world, by “exotic” phenomena that appear exceedingly foreign to my own intuitions and biases. Analyzing these patterns of linguistic expression has instilled in me great appreciation for human language, not only as a vehicle of communication, but as a system of computation that helps us plumb the depths of the human cognitive faculty.

What makes human language even more amazing is the ease with which children acquire it. While linguists struggle to make sense of intricate grammatical patterns, conflicting evidence, and unclear judgments, children need but a couple of years to acquire the major components of their native language (and are often able to simultaneously learn multiple languages). How is this remarkable feat possible?

Chomsky’s answer, and indeed the hypothesis that underlies modern linguistics, is that children are biologically endowed with the machinery necessary to acquire language—this is commonly known as Universal Grammar. In other words, language is *innate*. The burden of learning language, therefore, falls on this “genetic program”; “experience” is only required to the extent that it assists the child in choosing among an already limited set of alternatives.

So what does Universal Grammar provide? First, it makes available an inventory of primitive elements—some formal in nature, some semantic in nature—that languages draw upon in building linguistic expressions. Second, it enumerates a set of constraints that govern the derivation of linguistic structures. Finally, it delineates the interface between the computational system of language and the articulatory–perceptual system, on the one hand, and the conceptual–intentional system, on the other hand. By hypothesis, languages differ in two major respects: Different languages may employ different subsets of the primitive elements in the derivation process. The constraints on structure-building may also vary in a small number of predetermined ways. The interactions between these two parameters give rise to the diversity we observe in the world’s languages.

This work follows in the rich linguistic tradition sketched above. I have chosen to concentrate on a small area—certain phenomena within the Mandarin verb phrase—

and have attempted to develop a system of verbalizing heads and verbal roots to account for the richness of the Chinese verbal system. I have applied my framework to explain the derivation of inchoativity from underlying stative verbs and the formation of Mandarin resultative verb compounds, a challenging and much-debated phenomenon within the literature. True to the goal of understanding cross-linguistic variation, my work relates RVCs to resultative constructions in English. I have also speculated on why Mandarin “looks” so different from English, implicating a semantic property of stative roots in the process.

An aim of this inquiry is the simplification of grammatical processes. I have attempted to ground verb phrase structure in semantically-meaningful primitives and independently-motivated syntactic principles. Instead of positing two (or even more) independent representations, I developed the hypothesis that syntactic structure *is* event structure, and that verb meaning is compositionally “built up” in the syntax. The result is a much more transparent syntax–semantics interface, in which structural configurations correspond to clearly-defined relationships in the logical formal. A more “tightly-coupled” system, I believe, reduces the number of stipulation that must be made in order to account for various linguistic phenomena.

I have learned from many wise linguists that a piece of work is never complete. And furthermore, nothing is ever “right”. Therefore, the impact and quality of a theory can only be measured by the insights it reveals and the subsequent research it spurs. My own work is no exception: there are, no doubt, holes in my theory, counter-examples to my claims, and perhaps even internal inconsistencies. In addition, there is no guarantee that the pieces will still fit together as soon as one begins to consider a broader range of linguistic phenomena. Far from a depressing thought, I find this predicament refreshing and challenging. However, I must take the advice of the wise and conclude this inquiry here. The true value of my work, therefore, can only be evaluated by those who follow.

Appendix A

Abbreviations

1,2,3	1st, 2nd, 3rd person
ABS	absolutive
ABL	ablative
ACC	accusative
AGR	agreement (general)
ASP	aspect (general)
BEI	passive marker in Mandarin
CAUSE	causative morpheme
CL	classifier
COMP	complementizer
DAT	dative
DE	possessive marker, complementizer in Mandarin (among other uses)
DEC	declarative
DEF	definite
EXP	experience aspect
ERG	ergative
FUT	future
IMP	imperfective
LE	the particle <i>le</i> in Mandarin
M	masculine
NEG	negation
NOM	nominative
NPAST	non-past
QUANT	quantifier
PART	partive
PRT	particle
PAST	past tense
PERF	perfective
PERFECT	perfect
PP	past participle
REFL	reflexive
SG	singular
TOP	topic
VRM	verbal reflexive marking

Bibliography

- Alsina, Alex. 1992. On the argument structure of causatives. *Linguistic Inquiry* 23:517–555.
- Andersen, Roger W. 1990. Papiamentu tense-aspect, with special attention to discourse. In *Pidgin and creole tense-mood-aspect systems*, ed. J. V. Singler, 59–96. Amsterdam, The Netherlands: John Benjamins.
- Bach, Emmon. 1979. Control in Montague grammar. *Linguistic Inquiry* 10:515–553.
- Bach, Emmon. 1981. On time, tense, and aspect: An essay in English metaphysics. In *Radical pragmatics*, ed. P. Cole. New York: Academic Press.
- Baker, Mark. 1997. Thematic roles and syntactic structure. In *Elements of grammar*, ed. L. Haegeman. Dordrecht, The Netherlands: Kluwer Academic Publishers.
- Baker, Mark, and Osamuyimen T. Stewart. 1999. On double-headedness and the anatomy of the clause. Unpublished manuscript, Rutgers University.
- Baker, Mark C. 1988. *Incorporation: A theory of grammatical function changing*. Chicago, Illinois: University of Chicago Press.
- Baker, Mark C. 1989. Object sharing and projection in serial verb constructions. *Linguistic Inquiry* 20:513–553.
- Beck, David. 2002. *The typology of parts of speech systems: The markedness of adjectives*. New York: Routledge.
- Belletti, Adriana, and Luigi Rizzi. 1988. Psych-verbs and theta-theory. *Natural Language and Linguistic Theory* 6:291–352.
- Bohnenmeyer, Jürgen, and Mary Swift. 2001. Default aspect: The semantic interaction of aspectual viewpoint and telicity. In *Proceedings of Perspectives on Aspect*.
- Bonami, Olivier. 2001. A syntax-semantics interface for tense and aspect in French. In *Proceedings of the HPSG 2001 Conference*.
- Borer, Hagit. 1994. The projection of arguments. In *Functional projections*, ed. E. Benedicto and J. Runner, volume 17 of *University of Massachusetts Occasional Papers*. Amherst, Massachusetts: GSLA.

- Borer, Hagit. 2001. Exo-skeletal vs. endo-skeletal explanations: Syntactic projections and the lexicon. Unpublished manuscript, University of Southern California.
- Bouchard, Denis. 1995. *The semantics of syntax: A Minimalist approach to grammar*. Chicago, Illinois: University of Chicago Press.
- Bresnan, Joan. 1980. Control and complementation. *Linguistic Inquiry* 13:343–434.
- Bresnan, Joan, and Jonni M. Kanerva. 1989. Locative inversion in Chicheŵa: A case study of factorization in grammar. *Linguistic Inquiry* 20:1–50.
- Butt, Miriam, and Gillian Ramchand. 2001. Complex aspectual structure in Hindi/Urdu. In *Oxford working papers in linguistics, philology and phonetics*, ed. M. Liakata, B. Jensen, and D. Maillat, volume 6, 1–30. Oxford University.
- Carrier, Jill, and Janet H. Randall. 1992. The argument structure and syntactic structure of resultatives. *Linguistic Inquiry* 23:173–234.
- Carstens, Vicki. 2002. Antisymmetry and word order in serial constructions. *Language* 78:3–50.
- Carter, Richard J. 1976. Some constraints on possible words. *Semantikos* 1:27–66.
- Chan, Wing Ming. 1996. On the theory of aspect and Chinese aspect system. Doctoral Dissertation, Cornell University.
- Chang, Vincent W. 1986. The particle *le* in Chinese narrative discourse: an integrative description. Doctoral Dissertation, University of Florida.
- Chao, Yuen Ren. 1968. *A grammar of spoken Chinese*. Berkeley, California: University of California Press.
- Cheng, Lisa Lai-Shen, and C.-T. James Huang. 1994. On the argument structure of resultative compounds. In *In honor of William S.-Y. Wang interdisciplinary studies on language and language change*, ed. Matthew Chen and Ovid Tzeng, 187–221. Taipei, Taiwan: Pyramid Press.
- Chierchia, Gennaro. 1984. Topics in the syntax and semantics of infinitives and gerunds. Doctoral Dissertation, University of Massachusetts, Amherst.
- Chierchia, Gennaro. 1989. A semantics for unaccusatives and its syntactic consequences. Unpublished manuscript, Cornell University.
- Chomsky, Carol. 1969. *The acquisition of syntax in children from 5 to 10*. Cambridge, Massachusetts: MIT Press.
- Chomsky, Noam. 1981. *Lectures on government and binding*. Dordrecht, The Netherlands: Foris.

- Chomsky, Noam. 1982. *Some concepts and consequences of the theory of government and binding*. Cambridge, Massachusetts: MIT Press.
- Chomsky, Noam. 1995. *The Minimalist Program*. Cambridge, Massachusetts: MIT Press.
- Chomsky, Noam, and Howard Lasnik. 1995. The theory of Principles and Parameters. In *The Minimalist Program*. Cambridge, Massachusetts: MIT Press.
- Chu, Chauncey C. 1976. Some semantic aspects of action verbs. *Lingua* 40:43–54.
- Chung, Sandra, and Alan Timberlake. 1985. Tense, aspect, and mood. In *Language typology and syntactic description*, ed. Timothy Shopen, volume 3. Cambridge, England: Cambridge University Press.
- Collins, Chris. 1997. Argument sharing in serial verb constructions. *Linguistic Inquiry* 28:461–497.
- Comrie, Bernard. 1976. *Aspect*. Cambridge, England: Cambridge University Press.
- Croft, William. 1991. *Syntactic categories and grammatical relations*. Chicago, Illinois: University of Chicago Press.
- Croft, William. 1998. Event structure in argument linking. In *The projection of arguments: Lexical and compositional factors*, ed. Miriam Butt and Wilhelm Geuder. Stanford, California: CSLI Publications.
- Cuervo, Maria Cristina. 2003. Datives at large. Doctoral Dissertation, Massachusetts Institute of Technology.
- Culicover, Peter W., and Ray Jackendoff. 2001. Control is not movement. *Linguistic Inquiry* 32:493–512.
- Davidson, Donald. 1967. The logical form of action sentences. In *The logic of decision and action*, ed. N. Rescher, 81–95. Pittsburgh, Pennsylvania: University of Pittsburgh Press.
- de Swart, Hendriëtte. 1998. Aspect shift and coercion. *Natural Language and Linguistic Theory* 16:347–385.
- de Swart, Hendriëtte. 2000. Tense, aspect and coercion in a cross-linguistic perspective. In *Proceedings of the Berkeley Formal Grammar Conference*.
- den Dikken, Marcel. 1995. *Particles: On the syntax of verb-particle, triadic, and causative constructions*. Oxford, England: Oxford University Press.
- Dixon, Robert M.W. 1982. *Where have all the adjectives gone?: and other essays in semantics and syntax*. The Hague, The Netherlands: Mouton.

- Dowty, David. 1979. *Word meaning and Montague Grammar*. Dordrecht, The Netherlands: D. Reidel Publishing Company.
- Dowty, David. 1991. Thematic proto-roles and argument selection. *Language* 67:547–619.
- Embick, David. 2002. Remarks on the structure of resultative participles in English. Unpublished manuscript, University of Pennsylvania.
- Epstein, Samuel David. 1999. Un-principled syntax and the derivation of syntactic relations. In *Working Minimalism*, ed. Samuel David Epstein and Norbert Hornstein, 317–345. Cambridge, Massachusetts: MIT Press.
- Fagan, Sarah. 1992. *The syntax and semantics of middle constructions*. Cambridge, England: Cambridge University Press.
- Farkas, Donca F. 1988. On obligatory control. *Linguistics and Philosophy* 11:27–58.
- Fillmore, Charles J. 1968. The case for case. In *Universals in linguistic theory*, ed. E. Bach and R. Harms, 1–88. New York: Holt, Rinehart, and Winston.
- Gao, Mei Jia, and Hooi Ling Soh. 2003. An aspectual analysis of Mandarin verbal *-le* and sentential *-le*. Unpublished manuscript, Indiana University and University of Minnesota.
- Givón, Talmy. 1984. *Syntax: A functional-typological introduction*, volume 1. Amsterdam, The Netherlands: John Benjamins.
- Goldberg, Adele E. 1995. *Constructions: A construction grammar approach to argument structure*. Chicago, Illinois: University of Chicago Press.
- Goldberg, Adele E. 2001. Constructions, lexical semantics and the correspondence principle: Accounting for generalizations and subregularities in the realization of arguments. In *The syntax of aspect*, ed. Nomi Erteschik-Shir and Tova Rapoport. Ben-Gurion University of the Negev.
- Goldberg, Adele E., and Ray Jackendoff. 2003. The English resultative as a family of constructions. Unpublished manuscript, University of Illinois at Urbana-Champaign.
- Grice, Paul H. 1975. Logic and conversation. In *Speech acts*, ed. P. Cole and J.L. Morgan. New York: Academic Press.
- Grimshaw, Jane. 1993. Semantic structure and semantic content. Unpublished manuscript, Rutgers University, New Jersey.
- Gruber, Jeffrey S. 1965. Studies in lexical relations. Doctoral Dissertation, Massachusetts Institute of Technology.

- Hale, Kenneth, and Samuel Jay Keyser. 1993. On argument structure and the lexical expression of syntactic relations. In *The view from building 20: Essays in linguistics in honor of Sylvain Bromberger*, ed. Kenneth Hale and Samuel Jay Keyser. Cambridge, Massachusetts: MIT Press.
- Hale, Kenneth, and Samuel Jay Keyser. 1998. The basic elements of argument structure. In *Papers from the UPenn/MIT roundtable on argument structure and aspect: MIT working papers in linguistics 32*, ed. Heidi Harley, 73–118. Cambridge, Massachusetts: MITWPL.
- Hale, Kenneth, and Samuel Jay Keyser. 1999a. Bound features, merge, and transitivity alternations. In *Papers from the UPenn/MIT roundtable on the lexicon: MIT working papers in linguistics 35*, ed. Liina Pylkkänen, Angeliek van Hout, and Heidi Harley, 73–118. Cambridge, Massachusetts: MITWPL.
- Hale, Kenneth, and Samuel Jay Keyser. 1999b. A response to Fodor and Lepore, ‘impossible words?’. *Linguistic Inquiry* 30:453–466.
- Hale, Kenneth, and Samuel Jay Keyser. 2000. Conflation. In *Cuadernos de lingüística vii 2000, documentos de trabajo*, ed. Ana Bravo Martín, Carlos Luján Berenguel, and Isabel Pérez Jiménez. Madrid, Spain: Instituto Universitario Ortega y Gasset.
- Hale, Kenneth, and Samuel Jay Keyser. 2002. *Prolegomenon to a theory of argument structure*. Cambridge, Massachusetts: MIT Press.
- Halle, Morris, and Alec Marantz. 1993. Distributed morphology and the pieces of inflection. In *In the view from building 20*, ed. Kenneth Hale and Samuel Jay Keyser, 111–176. Cambridge, Massachusetts: MIT Press.
- Halle, Morris, and Alec Marantz. 1994. Some key features of distributed morphology. In *MITWPL 21: Papers on phonology and morphology*, ed. Andrew Carnie and Heidi Harley, 275–288. Cambridge, Massachusetts: MITWPL.
- Harley, Heidi. 1995. Subjects, events and licensing. Doctoral Dissertation, Massachusetts Institute of Technology.
- Harley, Heidi. 1996. If you *have*, you can *give*. In *Proceedings of the 15th West Coast Conference on Formal Linguistics (WCCFL 15)*.
- Haspelmath, Martin. 1993. More on the typology of inchoative/causative verb alternations. In *Causatives and transitivity*, ed. Bernard Comrie and Maria Polinsky. Amsterdam, The Netherlands: John Benjamins.
- Higginbotham, James. 1980. Pronouns and bound variables. *Linguistic Inquiry* 11:679–708.
- Higginbotham, James. 1985. On semantics. *Linguistic Inquiry* 16:547–593.
- Hoekstra, Teun. 1988. Small clause results. *Lingua* 74:101–139.

- Hoekstra, Teun. 1992. Aspect and theta theory. In *Thematic structure: Its role in grammar*, ed. I. M. Roca, 145–174. Berlin, Germany: Foris.
- Hopper, Paul J., and Sandra A. Thompson. 1980. Transitivity in grammar and discourse. *Language* 56:251–299.
- Hornstein, Norbert. 1990. Verb raising in Icelandic infinitives. In *Proceedings of the 20th Annual Meeting of NELS*.
- Hornstein, Norbert. 1999. Movement and control. *Linguistic Inquiry* 30:69–96.
- Hornstein, Norbert. 2001. *Move! A Minimalist Theory of Control*. Oxford, England: Blackwell Publishers.
- Hornstein, Norbert, and Hirohisa Kiguchi. 2002. PRO gate and sideward movement. In *Generative Linguistics in the Old World (GLOW) in Asia 2002*.
- Huang, C.-T. James. 1988. *Wo pao de kuai* and Chinese phrase structure. *Language* 64:274–311.
- Huang, C.-T. James. 1992. Complex predicates in control. In *Control and grammar*, ed. Richard K. Larson, Sabine Iatridou, Utpal Lahiri, and James Higginbotham. Dordrecht, The Netherlands: Kluwer Academic Publishers.
- Huang, C.-T. James. 1998. PRO-drop in Chinese: A generalized control theory. In *The null subject parameter*, ed. Osvaldo Jaeggli and Kenneth Safir, 185–214. Dordrecht, The Netherlands: Kluwer Academic Publishers.
- Huang, Chu-Ren, and Fu-Wen Lin. 1992. Composite event structures and complex predicates: A template-based approach to argument selection. In *Proceedings of the Third Annual Meeting of the Formal Linguistic Society of Midamerica (FLSM III)*.
- Ikegami, Yoshihiko. 1985. ‘Activity’—‘accomplishment’—‘achievement’—a language that can’t say ‘I burned it, but it didn’t burn’ and one that can. In *Linguistics and philosophy: Essays in honor of Rulon S. Wells*, ed. A. Makkai and A. K. Melby, 265–304. Amsterdam, The Netherlands: John Benjamins.
- Jackendoff, Ray. 1972. *Semantic interpretation in generative grammar*. Cambridge, Massachusetts: MIT Press.
- Jackendoff, Ray. 1983. *Semantics and cognition*. Cambridge, Massachusetts: MIT Press.
- Jackendoff, Ray. 1990. *Semantic structures*. Cambridge, Massachusetts: MIT Press.
- Jackendoff, Ray. 1991. Parts and boundaries. *Cognition* 41:9–45.

- Jackendoff, Ray. 1996. The proper treatment of measuring out, telicity, and perhaps even quantification in English. *Natural Language and Linguistic Theory* 14:305–354.
- Jespersen, Otto. 1939. The history of a suffix. *International Journal of Structural Linguistics* 1:48–56.
- Johnson, Kyle. 1991. Object positions. *Natural Language and Linguistic Theory* 9:577–636.
- Kamp, Hans, and Uwe Reyle. 1993. *From discourse to logic*. Dordrecht, The Netherlands: Kluwer Academic Publishers.
- Katz, Graham. 2000. Anti neo-Davidsonianism: Against a Davidsonian semantics for state sentences. In *Events as grammatical objects*, ed. Carol Tenny and James Pustejovsky, 393–416. Stanford, California: CSLI Publications.
- Kawasaki, Noriko. 1993. Control and arbitrary interpretation in English. Doctoral Dissertation, University of Massachusetts, Amherst.
- Kayne, Richard. 1985. Principles of particle constructions. In *Grammatical representations*, ed. J. Guéron, H.-G. Obenauser, and J.-Y. Pollock. Dordrecht, The Netherlands: Foris.
- Kenny, Anthony. 1963. *Action, emotion and will*. London, England: Routledge & Kegan Paul.
- Kiguchi, Hirohisa. 2000. PRO gate and movement. Unpublished manuscript, University of Maryland.
- Kim, Soowon, and Joan Maling. 1997. A crosslinguistic perspective on resultative formation. In *Texas Linguistic Forum* 38.
- Kitagawa, Yoshihisa. 1986. Subjects in Japanese and English. Doctoral Dissertation, University of Massachusetts, Amherst.
- Klein, Wolfgang. 1994. *Time in language*. London, England: Routledge.
- Klein, Wolfgang. 2001. Time and again. In *Festschrift for Arnim von Stechow*, ed. C. Féry and W. Sternefeld.
- Koenig, Jean-Pierre, and Nuttanart Muansuwan. 2000. How to end without ever finishing: Thai semi-perfectivity. *Journal of Semantics* 17:147–184.
- Koontz-Garboden, Andrew. 2004. Tongan and the typology of change of state predicates. Unpublished manuscript, Stanford University.
- Koontz-Garboden, Andrew, and Beth Levin. 2004. How are states related to changes of state? In *The 78th Annual Meeting of the Linguistic Society of America*.

- Koopman, Hilda, and Dominique Sportiche. 1991. The position of subjects. *Lingua* 85:211–259.
- Koster, Jan. 1984. On binding and control. *Linguistic Inquiry* 15:417–459.
- Kratzer, Angelika. 1994. The event argument and the semantics of voice. Unpublished manuscript, University of Massachusetts, Amherst.
- Kratzer, Angelika. 2000. Building statives. In *Proceedings of the 26th Annual Meeting of the Berkeley Linguistics Society*.
- Krifka, Manfred. 1992. Thematic relations as links between nominal reference and temporal constitution. In *Lexical matters*, ed. Ivan A. Sag and Anna Szabolcsi, 29–53. Stanford, California: CSLI Publications.
- Krifka, Manfred. 1998. The origins of telicity. In *Events and grammar*, ed. Susan Rothstein, 197–235. Dordrecht, The Netherlands: Kluwer Academic Publishers.
- Kuroda, S.-Y. 1988. Whether we agree or not: A comparative syntax of English and Japanese. *Linguisticae Investigaciones* 12:1–47.
- Lakoff, George. 1966. Stative adjectives and verbs in English. NSF-Report 17, Harvard Computational Laboratory.
- Lakoff, George. 1971. On generative semantics. In *Semantics: An interdisciplinary reader in philosophy, linguistics, and psychology*, ed. D. Steinberg and L. Jakobovits, 232–296. Cambridge, England: Cambridge University Press.
- Landau, Idan. 1999. Elements of control. Doctoral Dissertation, Massachusetts Institute of Technology.
- Landau, Idan. 2003. Movement out of control. *Linguistic Inquiry* 34:471–498.
- Larson, Richard K. 1988. On the double object construction. *Linguistic Inquiry* 19:335–391.
- Larson, Richard K. 1991. Promise and the theory of control. *Linguistic Inquiry* 22:103–140.
- Levin, Beth. 1999. Objecthood: An event structure perspective. In *Proceedings of the 35th Annual Meeting of the Chicago Linguistics Society*.
- Levin, Beth. 2000. Aspect, lexical semantic representation, and argument expression. In *Proceedings of the 26th Annual Meeting of the Berkeley Linguistics Society*.
- Levin, Beth, and Malka Rappaport Hovav. 1986. The formation of adjectival passives. *Linguistic Inquiry* 17:623–661.
- Levin, Beth, and Malka Rappaport Hovav. 1995. *Unaccusativity: At the syntax-lexical semantics interface*. Cambridge, Massachusetts: MIT Press.

- Levin, Beth, and Malka Rappaport Hovav. 1996. From lexical semantics to argument realization. Unpublished manuscript, Northwestern University and Bar Ilan University.
- Li, Charles N., and Sandra A. Thompson. 1981. *Mandarin Chinese: A functional reference grammar*. Berkeley, California: University of California Press.
- Li, Ping. 1989. Aspect and aktionsart in child Mandarin. Doctoral Dissertation, University of Leiden, Netherlands.
- Li, Yafei. 1990. On V-V compounds in Chinese. *Natural Language and Linguistic Theory* 9:177–207.
- Li, Yafei. 1995. The thematic hierarchy and causativity. *Natural Language and Linguistic Theory* 13:255–282.
- Li, Yafei. 1999. Cross-componential causativity. *Natural Language and Linguistic Theory* 17:445–497.
- Lidz, Jeffrey, and Alexander Williams. 2002. Reflexivity and resultatives. In *Proceedings of the 21st West Coast Conference on Formal Linguistics (WCCFL 21)*.
- Lin, Jo-Wang. 2003. Temporal reference in Mandarin Chinese. *Journal of East Asian Linguistics* 12:259–311.
- Lin, Tzong-Hong. 2001. Light verb syntax and the theory of phrase structure. Doctoral Dissertation, University of California, Irvine.
- Liu, Feng-Hsi. 1997. An aspectual analysis of *ba*. *Journal of East Asian Linguistics* 6:51–99.
- Manzini, Maria Rita. 1983. On control and control theory. *Linguistic Inquiry* 14:421–446.
- Marantz, Alec. 1984. *On the nature of grammatical relations*. Cambridge, Massachusetts: MIT Press.
- Marantz, Alec. 1997. No escape from syntax: Don't try morphological analysis in the privacy of your own lexicon. In *Proceedings of the 21st Annual Penn Linguistics Colloquium*.
- Martin, Roger A. 1996. A minimalist theory of PRO and control. Doctoral Dissertation, University of Connecticut.
- McCawley, James D. 1968. Lexical insertion in a transformational grammar without dep structure. In *Papers from the fourth meeting of the Chicago Linguistic Society*, ed. B. Darden, C.-J. N. Bailey, and A. Davison. Chicago, Illinois: University of Chicago, Department of Linguistics.

- McCawley, James D. 1973. Syntactic and logical arguments for semantic structure. In *Three dimensions in linguistic theory*, ed. Osamu Fujimura, 259–376. Tokyo: TEC Corporation.
- McGinnis, Martha. 2000. Event heads and the distribution of psych-roots. In *Current work in linguistics: University of Pennsylvania working papers in linguistics 6:3*, ed. Alexander Williams and Elsi Kaiser. University of Pennsylvania, Department of Linguistics.
- Moens, Marc, and Mark Steedman. 1988. Temporal ontology and temporal reference. *Computational Linguistics* 14:15–28.
- Monahan, Philip J. 2003. Backward object control in Korean. In *Proceedings of the 22nd West Coast Conference on Formal Linguistics (WCCFL 22)*.
- Nedjalkov, Vladimir P. 1969. Nekotorye verojatnostnye universalii v glagol'nom slovoobrazovanii. In *Jazykovye universalii i lingvističeskaja tipologija*, ed. I. F. Vardul', 106–114. Moscow: Nauka.
- Nishiyama, Kunio. 1998. V-V compounds as serialization. *Journal of East Asian Linguistics* 7:175–217.
- Nunes, Jairo. 1995. The copy theory of movement and linearization of chains in the Minimalist Program. Doctoral Dissertation, University of Maryland, College Park.
- O'Neil, John H. 1997. Means of control: Deriving the properties of PRO in the Minimalist Program. Doctoral Dissertation, Harvard University.
- Parsons, Terence. 1990. *Events in the semantics of English: A study in subatomic semantics*. Cambridge, Massachusetts: MIT Press.
- Perlmutter, David, and Paul Postal. 1984. The 1-advancement exclusiveness law. In *Studies in Relational Grammar*, ed. David Perlmutter and Carol Rosen. Chicago, Illinois: University of Chicago Press.
- Pesetsky, David. 1995. *Zero syntax: Experiencer and cascades*. Cambridge, Massachusetts: MIT Press.
- Piñón, Christopher. 2001. A finer look at the causative-inchoative alternation. In *Proceedings of Semantics and Linguistic Theory 11*.
- Pinker, Steven. 1989. *Learnability and cognition*. Cambridge, Massachusetts: MIT Press.
- Poeppl, David, and Kenneth Wexler. 1993. The full competence hypothesis of clause structure in early German. *Language* 69:1–33.
- Polinsky, Maria, and Eric Potsdam. 2001. Long-distance agreement and topic in Tsez. *Natural Language and Linguistic Theory* 19:583–646.

- Postal, Paul M. 1970. On the surface verb “Remind”. *Linguistic Inquiry* 1:37–120.
- Pustejovsky, James. 1991. The syntax of event structure. *Cognition* 41:47–81.
- Pylkkänen, Liina. 2002. Introducing arguments. Doctoral Dissertation, Massachusetts Institute of Technology.
- Ramchand, Gillian. 2003. First phase syntax. Unpublished manuscript, University of Oxford.
- Ramchand, Gillian, and Peter Svenonius. 2002. The lexical syntax and lexical semantics of the verb-particle construction. In *Proceedings of the 21st West Coast Conference on Formal Linguistics (WCCFL 21)*.
- Ramchand, Gillian Catriona. 1998. Deconstructing the lexicon. In *The projection of arguments: Lexical and compositional factors*, ed. Miriam Butt and Wilhelm Geuder. Stanford, California: CSLI Publications.
- Ramchand, Gillian Catriona. 2001. Aktionsart, l-syntax and selection. In *Proceedings of Perspectives on Aspect*.
- Rapoport, Tova. 1999. The English middle and agentivity. *Linguistic Inquiry* 30:147–155.
- Rappaport Hovav, Malka, and Beth Levin. 1998. Building verb meanings. In *The projection of arguments: Lexical and compositional factors*, ed. Miriam Butt and Wilhelm Geuder. Stanford, California: CSLI Publications.
- Rappaport Hovav, Malka, and Beth Levin. 2001. An event structure account of English resultatives. *Language* 77:766–797.
- Rappaport Hovav, Malka, and Beth Levin. 2003. Root and template in the representation of verb meaning. Handout, The Hebrew University of Jerusalem and Stanford University.
- Ritter, Elizabeth, and Sara Thomas Rosen. 1998. Delimiting events in syntax. In *The projection of arguments: Lexical and compositional factors*, ed. Miriam Butt and Wilhelm Geuder. Stanford, California: CSLI Publications.
- Ritter, Elizabeth, and Sara Thomas Rosen. 2001. The interpretive value of object splits. *Language Sciences* 23:425–451.
- Rohsenow, John S. 1977. Perfect *le*: Aspect and relative tense in Mandarin Chinese. In *Proceedings of Symposium on Chinese Linguistics, 1977 Linguistic Institute of the Linguistic Society of America*.
- Rosen, Carol. 1984. The interface between semantic roles and initial grammatical relations. In *Studies in Relational Grammar*, ed. David Perlmutter and Carol Rosen, 38–77. Chicago, Illinois: University of Chicago Press.

- Rosenbaum, Peter. 1967. *The grammar of English predicate complement constructions*. Cambridge, Massachusetts: MIT Press.
- Ross, Claudia. 1995. Temporal and aspectual reference in Mandarin Chinese. *Journal of Chinese Linguistics* 23:87–136.
- Ryle, Gilbert. 1949. *The concept of mind*. Chicago, Illinois: The University of Chicago Press.
- Shi, Ziqiang. 1988. The present of past of the particle *le* in Mandarin Chinese. Doctoral Dissertation, University of Pennsylvania.
- Shi, Ziqiang. 1990. Decomposition of perfectivity and inchoativity and the meaning of the particle *le* in Mandarin Chinese. *Journal of Chinese Linguistics* 18:95–123.
- Sigurðsson, Halldór Ármann. 1991. Icelandic case-marked PRO and the licensing of lexical arguments. *Natural Language and Linguistic Theory* 9:327–363.
- Simpson, Jane. 1983. Resultatives. In *Papers in Lexical-Functional Grammar*, ed. Lori Levin, Malka Rappaport, and Annie Zaenen, 143–157. Bloomington, Indiana: Indiana University Linguistics Club.
- Singh, Mona. 1998. On the semantics of the perfective aspect. *Natural Language Semantics* 6:171–199.
- Smith, Carlota S. 1991. *The parameter of aspect*. Dordrecht, The Netherlands: Kluwer Academic Publishers.
- Soh, Hooi Ling, and Jenny Yi-Chun Kuo. 2001. Perfective aspect and accomplishment situations in Mandarin Chinese. In *Proceedings of Perspectives on Aspect*.
- Stowell, Tim. 1981. Elements of phrase structure. Doctoral Dissertation, Massachusetts Institute of Technology.
- Sybesma, Rint. 1997. Why Chinese verb-*le* is a resultative predicate. *Journal of East Asian Linguistics* 6:215–261.
- Sybesma, Rint. 1999. *The Mandarin VP*. Dordrecht, The Netherlands: Kluwer Academic Publishers.
- Tai, James H-Y. 1984. Verbs and times in Chinese: Vendler's four categories. In *Papers from the parasession on lexical semantics*, ed. David Testen, Veena Mishra, and Joseph Drogo. Chicago, Illinois: Chicago Linguistic Society.
- Tai, James H-Y., and Jane Y. Chou. 1975. On the equivalent of 'kill' in Mandarin Chinese. *Journal of the Chinese Language Teachers Association* 10:48–52.
- Talmy, Leonard. 1976. Semantic causative types. In *Syntax and semantics 6: The grammar of causative constructions*, ed. M. Shibatani, 43–116. New York: Academic Press.

- Talmy, Leonard. 1988. Force dynamics in language and thought. *Cognitive Science* 12:49–100.
- Tenny, Carol. 1987. Grammaticalizing aspect and affectedness. Doctoral Dissertation, Massachusetts Institute of Technology.
- Tenny, Carol. 1992. The Aspectual Interface Hypothesis. In *Lexical matters*, ed. Ivan A. Sag and Anna Szabolcsi. Stanford, California: CSLI Publications.
- Tenny, Carol. 1994. *Aspectual roles and the syntax-semantics interface*. Dordrecht, The Netherlands: Kluwer Academic Publishers.
- Travis, Lisa. 1984. Parameters and effects of word order variation. Doctoral Dissertation, Massachusetts Institute of Technology.
- Travis, Lisa. 1994. Event phrase and a theory of functional categories. In *Proceedings of the 1994 Annual Conference of the Canadian Linguistic Association*.
- Van Valin, Robert D. 1993. A synopsis of Role and Reference Grammar. In *Advances in Role and Reference Grammar*, ed. Robert D. Van Valin. Amsterdam, The Netherlands: John Benjamins.
- Van Valin, Robert D., and Randy J. LaPolla. 1997. *Syntax. structure, meaning and function*. Cambridge, England: Cambridge University Press.
- van Voorst, Jan G. 1986. Event structure. Doctoral Dissertation, University of Ottawa, Ontario.
- Vendler, Zeno. 1957. Verbs and times. *Philosophical Review* 56:143–160.
- Vendler, Zeno. 1967. *Linguistics in philosophy*. Ithaca, New York: Cornell University Press.
- Verkuyl, Henk J. 1972. *On the compositional nature of the aspects*. Dordrecht, The Netherlands: D. Reidel Publishing Company.
- Verkuyl, Henk J. 1993. *A theory of aspectuality: The interaction between temporal and atemporal structure*. Cambridge, England: Cambridge University Press.
- Verkuyl, Henk J. 1995. Aspectual classes and aspectual composition. *Linguistics and Philosophy* 2:39–94.
- Visser, Fredericus Theodorus. 1973. *An historical syntax of the English language*. Leiden: E. J. Brill.
- von Stechow, Arnim. 1995. Lexical decomposition in syntax. In *Lexical knowledge in the organization of language*, ed. Urs Egli, Peter E. Pause, Christoph Schwarze, Arnim von Stechow, and Götz Wienold, 81–118. Amsterdam, The Netherlands: John Benjamins.

- von Stechow, Arnim. 1996. The different readings of *wieder* ‘again’: A structural account. *Journal of Semantics* 13:87–138.
- von Stechow, Arnim. 1999. How are results represented and modified? Remarks on Jäger & Blutner’s anti-decomposition. In *Proceedings of the Oslo Conference on Adverbs*.
- Wang, William S.Y. 1965. Two aspect markers in Chinese. *Language* 41:457–470.
- Washio, Ryuichi. 1997. Resultatives, compositionality and language variation. *Journal of East Asian Linguistics* 6:1–49.
- Weber, David J. 1989. *A grammar of Huallaga (Huánuco) Quechua*. Berkeley, California: University of California Press.
- Wechsler, Stephen. 1997. Resultative predicates and control. In *Texas Linguistic Forum* 38.
- Wechsler, Stephen, and Bokyoung Noh. 2001. On resultative predicates and clauses: Parallels between Korean and English. *Language Sciences* 23:391–423.
- Williams, Alexander. 2002. Complex causative and verbal valence. Unpublished manuscript, University of Pennsylvania.
- Williams, Edwin. 1980. Predication. *Linguistic Inquiry* 11:203–338.
- Wurmbrand, Susi. 1998. Infinitives. Doctoral Dissertation, Massachusetts Institute of Technology.
- Wurmbrand, Susi. 2002. Syntactic vs. semantic control. In *Studies in comparative germanic syntax*, ed. Jan-Wouter Zwart and Werner Abraham, 95–129. Amsterdam, The Netherlands: John Benjamins.
- Zhang, Niina. 2001a. On the pre-predicate *lai* and *qu* in Chinese. Unpublished manuscript, Centre for General Linguistics, Typology and Universals Research (ZAS).
- Zhang, Niina. 2001b. The structures of depictive and resultative constructions in Chinese. *Papers in Linguistics* 22, Centre for General Linguistics, Typology and Universals Research (ZAS).
- Zou, Ke. 1994. Resultatives V-V compounds in Chinese. In *MIT working papers in linguistics* 22, ed. Heidi Harley and Colin Phillips, 271–290. Cambridge, Massachusetts: MITWPL.