

INFORMATION TO USERS

This manuscript has been reproduced from the microfilm master. UMI films the text directly from the original or copy submitted. Thus, some thesis and dissertation copies are in typewriter face, while others may be from any type of computer printer.

The quality of this reproduction is dependent upon the quality of the copy submitted. Broken or indistinct print, colored or poor quality illustrations and photographs, print bleedthrough, substandard margins, and improper alignment can adversely affect reproduction.

In the unlikely event that the author did not send UMI a complete manuscript and there are missing pages, these will be noted. Also, if unauthorized copyright material had to be removed, a note will indicate the deletion.

Oversize materials (e.g., maps, drawings, charts) are reproduced by sectioning the original, beginning at the upper left-hand corner and continuing from left to right in equal sections with small overlaps. Each original is also photographed in one exposure and is included in reduced form at the back of the book.

Photographs included in the original manuscript have been reproduced xerographically in this copy. Higher quality 6" x 9" black and white photographic prints are available for any photographs or illustrations appearing in this copy for an additional charge. Contact UMI directly to order.

UMI

A Bell & Howell Information Company
300 North Zeeb Road, Ann Arbor MI 48106-1346 USA
313/761-4700 800/521-0600

**Sign-Based Morphology and Phonology
with special attention to Optimality Theory**

by

Cemil Orhan Orgun

B.S. (University of the Bosphorous, Turkey) 1988

M.S. (University of California, Berkeley) 1991

M.A. (University of California, Berkeley) 1993

A dissertation submitted in partial satisfaction of the

requirements for the degree of

Doctor of Philosophy

in

Linguistics

in the

GRADUATE DIVISION

of the

UNIVERSITY OF CALIFORNIA, BERKELEY

Committee in charge:

Professor Larry M. Hyman, Chair

Professor Jaye Padgett

Professor Andreas Kathol

Professor Thomas F. Shannon

Fall 1996

UMI Number: 9723132

UMI Microform 9723132
Copyright 1997, by UMI Company. All rights reserved.

**This microform edition is protected against unauthorized
copying under Title 17, United States Code.**

UMI
300 North Zeeb Road
Ann Arbor, MI 48103

The dissertation of Cemil Orhan Orgun is approved:

Larry M. Hyman Dec. 11, 1996
Chair Date

Jay Padgett Dec. 12, 1996
Date

Andreas Kerkel 12/11/1996
Date

Thomas Zeman 12/17/96
Date

University of California, Berkeley

Fall 1996

**Sign-Based Morphology and Phonology
with special attention to Optimality Theory**

© 1996

by

Cemil Orhan Orgun

Table of contents

1. Introduction.....	1
1.1 Goals	2
1.2 Sign-based linguistics	8
1.3 Optimality Theory	12
1.4 What does “nonderivational” mean?	15
1.4.1 Derivational models	16
1.4.2 Nonderivational models	19
1.4.3 Why sign-based linguistics is nonderivational.....	23
1.4.4 Advanced formal considerations.....	25
2. Cyclic and noncyclic phonological effects.....	29
2.1 Turkish prosodic minimality.....	29
2.2 Suspended Affixation.....	38
2.3 Optimality Theoretic analysis of Turkish minimality	47
2.4 Ondarroa Basque vowel height assimilation.....	51
2.5 Optimality Theoretic analysis of Basque vowel height assimilation	54
2.6 Cyclic and noncyclic effects in Basque vowel height assimilation.....	58
3. Connections to other theories.....	63
3.1 Why Sign-Based Morphology is different	63
3.2 Why Sign-Based Morphology is not different	68

3.2.1 From Lieber 1980 to Sign-Based Morphology: the item-and-arrangement connection	68
3.2.2 The item-and-process connection	76
3.3 The sign-based connection.....	89
3.4 Sign-Based Morphology how-to	92
3.4.1 Compounding.....	92
3.4.2 Affixation.....	93
3.4.3 Nonconcatenative morphology	95
3.4.4 What is a morpheme?	100
3.5 Comparison of Sign-Based Morphology with paradigmatic approaches to morphology	103
3.5.1 Strictly paradigmatic approaches	103
3.5.2 Loosely paradigmatic approaches	105
3.5.3 Syntagmatic approaches enriched with transderivational identity	108
3.5.4 More on the paradigmatic interpretation of Sign-Based Morphology	109
3.5.5 Comparison of Sign-Based Morphology with strictly paradigmatic approaches.....	113
3.5.6 Comparison of Sign-Based Morphology with loosely paradigmatic approaches and syntagmatic approaches with transderivational identity.....	119
3.5.7 Level economy in the paradigmatic approach.....	141
3.5.8 Noncyclic phonological effects in the syntagmatic approach with transderivational identity.....	143

3.5.9 Summary of the paradigmatic aspect of Sign-Based Morphology.....	152
4. Cophonologies and Level Ordering	154
4.1 Level ordering: the standard view.....	154
4.2 Introduction to cophonologies	157
4.3 Cophonologies and level ordering	161
4.4 How different can cophonologies be?.....	172
4.4.1 Example of an unwanted language	172
4.4.2 The Strong Domain Hypothesis and the Uniform Domain Hypothesis.....	173
4.4.3 How restrictive is the Uniform Domain Hypothesis?	175
4.4.4 An insight from Optimality Theory: focus on the output	176
4.4.5 A Learnability Hypothesis: Hypothetical Language B.....	179
4.4.6 Some spurious cophonology proliferation problems	180
4.4.7 Review of cophonology proliferation	184
4.5 Levels in the Turkish lexicon.....	186
4.6 Modeling the Strict Layer Hypothesis	194
4.7 Challenges to level ordering	197
4.7.1 Level jumping	198
4.7.2 Level economy	203
4.7.3 The loop	208
4.7.4 Clustering.....	223
4.8 General evaluation of level ordering.....	226
5. Reference to lexical types	229

5.1 Introduction.....	229
5.2 Reasons to revive Bracket Erasure.....	231
5.2.1 Illustration of Bracket Erasure	231
5.2.2 Challenges to Bracket Erasure	235
5.2.3 Types.....	237
5.3 Reference to lexical types in English.....	240
5.4 Phonological analysis of <i>re</i> -verb nominalization.....	251
5.5 Cophonological allomorphy.....	257
5.5.1 Japanese deverbal noun accentuation	257
5.5.2 Breton mutation	263
5.5.3 Turkish place name stress	266
5.5.4 Ulwa possessives	271
5.6 Cyclic effects in Cibemba	274
5.6.1 Data.....	275
5.6.2 Hyman's cyclic analysis.....	277
5.6.3 Analysis based on cophonological allomorphy.....	278
5.7 Conclusions.....	283
6. Remarks on the choice of phonological theory.....	284
6.1 One level phonology	285
6.2 Cyclic effects in one-level phonology.....	287
6.3 Structure changing alternations.....	290
6.4 Critique of one-level phonology	296

6.4.1 The spirit of unification-based theories	296
6.4.2 Bengali laryngeal assimilation	302
7. Conclusion	305

List of Abbreviations

1. Glosses

1	First person
1du	First person dual
1pl	First person plural
1pl.poss	First person plural possessor
1pl.sbj	First person plural subject
1sg.poss	First person singular possessor
2du	Second person dual
2pl	Second person plural
2pl.poss	Second person plural possessor
2pl.sbj	Second person plural subject
2sg	Second person singular
2sg.poss	Second person singular possessor
2sg.sbj	Second person singular subject
3pl.pret	Third person plural, preterite (portmanteau morph)
3sg.poss	Third person singular possessive
3sg.sbj	Third person singular subject
abil	Abilitative (possibility or ability)
abl	Ablative
abs.pl	Absolute plural
abs.sg	Absolute singular

acc	Accusative
adj	Adjective
adv	Adverb
agt	Agentive noun
caus	Causative
cond	Conditional
dat	Dative
dim	Diminutive
du.sbj	Dual subject
dur	Durative
erg	Ergative
evld	Evidential
fut	Future
gen	Genitive
imprf	Imperfective
inc.du.sbj	Inclusive dual subject
iter	Iterative
loc	Locative
m.obj	Masculine object
mnr	Manner adverb
neg	Negative
neg.imprf	Negative imperfective

noml	Nominal
part	Partitive
pass	Passive
perf	Perfective
pl	Plural
pl.obj	Plural object
pl.sbj	Plural subject
poss	Possessed
ppl	Participle
pres	Present
prog	Progressive
rel	Relative
sbj.pers	Subject person (agreement)
sg	Singular
sub	Subordinate

2. Attribute names

AGR	Agreement
CAT	Syntactic category
cont	Continuant
DTRS	Daughters
hi	High

lo	Low
MORPH	Morphological structure
nas	Nasal
PERS	Person
PHON	Phonology
PL	Plural
PRES	Present
SEM	Semantics
SL	Supralaryngeal
SYN	Syntax
SYNSEM	Syntax and semantics

3. Optimality Theoretic Constraints and terms

ACC-LOC	A syllable that is accented in the input must be accented in the output
ALIGN(X, {L,R}, Y, {L,R})	For all X, there is a Y such that the {left, right} edge of X coincides with the {left, right} edge of Y
DEP	Dependence (no insertion)
EVAL	Evaluation with respect to grammatical constraint system
HEAD-IDENT	A syllable that is stressed in the input must be stressed in the output
LEX \approx PR	A lexical word must be a prosodic word (must contain a

	foot)
MAX	Maximality (no deletion)
MPARSE	Morphological parsing (requires a phonological output)
NLV	No long vowel
OCP	Obligatory Contour Principle

4. Miscellaneous

CG	Construction Grammar
GB	Government and Binding
GPSG	Generalized Phrase Structure Grammar
HPSG	Head-Driven Phrase Structure Grammar
LFG	Lexical Functional Grammar
min	Minimum (prosodic size condition)
SR	Surface representation
SSN	Stress shifting nominalization; stress-shifted nominal
UR	Underlying representation

Acknowledgments

I thank my committee members Larry Hyman, Jaye Padgett, Andreas Kathol, and Thomas Shannon for all the incredible help and attention they have given me. I hope this dissertation does justice to their superhuman efforts.

I especially want to thank my advisor Larry Hyman, who has always helped and guided me in not just work related to my dissertation, but in everything I needed help with.

I am grateful to other people in the department who have given me so much valuable input that they too could very easily have been members of my thesis committee. Foremost among those are Paul Kay and Chuck Fillmore. Thanks to both for showing me the delights of unification-based grammar. I also thank Rich Rhodes and Karl Zimmer for giving me many crucial insights in their quiet and understated way. Sharon has also been a great advisor, a great colleague, and a great student.

My work has also benefited greatly from my interaction with Farrell Ackerman and David Perlmutter during the very short and very busy period we spent together at UCSD. I am proud to have been their colleague.

I also thank Mark Ellison, Jim Scobbie, Steve Anderson, Greg Stump, Ivan Sag and John Goldsmith for discussing my work with me. I owe many of the insights in this thesis to them. I have also benefited from discussions with András Kornai, Chris Manning and Susanne Riehemann. I thank them, and all the countless other people who have influenced my work.

I am truly grateful to John McCarthy for writing his LI paper on nonconcatenative morphology. The day I read that paper, I decided to become a formal phonologist and morphologist—I was so struck by its beauty.

I thank the Volaré for everything it's done for me. I thank Aylin Küntay and Hans-Robert Cram for getting me interested in linguistics, Nina Lübbren and Anindo Banerjea for giving me the determination, Ayfer Bartu for giving me the courage to do it, and Vic van Niekerk for not letting me feel bad about quitting engineering. I am grateful to Eve Sweetser for telling me exactly what it would be like to be a linguistics student.

I am grateful to my fellow students for putting up with me, and listening to even my strangest ideas. I am especially grateful to Dan Jurafsky and Jean-Pierre Koenig, both for their amazing dedication to their work, and for all they've done for me. Their devotion to linguistics and their relentless attention to rigor, and their love of sushi made me the linguist I am. I thank Cheryl Zoll for being a great friend and for never failing to encourage me, even at my most depressive moments. I am also proud to be a coworker of Andy Dolbey and Ron Sprouse. Andy's interest in Sign-Based Morphology is my best assurance that it is a worthwhile enterprise. And Ron, thank you for teaching me to relax. not worry, have a homebrew.

Thank you, Jem Bebek, for being so sweet and cute, and for making me get up early everyday. Thank you Gügü for not making me live in Ithaca instead of Berkeley. Thank you Ana and Gün for always being there.

Chapter 1. Introduction

In this study, I develop the theory of Sign-Based Morphology, a novel, declarative approach to the phonology-morphology interface, following up on Orgun 1994b,c, 1995a,b,c, 1996b.¹ Theories of morphology are traditionally assigned one of the following classifications: Item-and-Arrangement, Item-and-Process, and Word-and-Paradigm. Sign-Based Morphology shares properties of all these three approaches. It combines insights from constituent structure-based views of morphology on the one hand and realizational views on the other, thus building on ideas in both item-and-arrangement and item-and-process approaches to morphology. It also has a plausible paradigmatic interpretation, thus incorporating insights of the Word-and-Paradigm approach as well. By using insights from these approaches to morphology, which are usually assumed to be mutually incompatible, Sign-Based Morphology manages not only to capture all their advantages, but also to avoid their pitfalls.

A number of basic properties of the phonology-morphology interaction must be handled by a satisfactory theory. These are summarized in (1):

- (1) a) Account for cyclic phonological effects
- b) Account for noncyclic phonological effects

¹ A number of researchers have used the framework of Sign-Based Morphology in their work. These include Dolbey 1996, Dolbey and Orgun 1996, Inkelas 1996, Inkelas and Orgun 1996, Moddeé 1996 and Koenig et al. 1996.

- c) Relate the cyclic-noncyclic contrast to independently motivated morphological properties of words
- d) Predict the inside-out nature of cyclic effects
- e) Account for Bracket Erasure effects (do not allow unlimited reference to the internal structure of words by the grammar)
- f) Handle challenges to Bracket Erasure
- g) Account for “level economy” effects (the exemption of forms from the phonology of levels where they do not undergo morphology)
- h) Use only independently motivated analytical tools

Past approaches to the phonology-morphology interface have aimed to capture various subsets of these desiderata, but none have targeted the whole range. Sign-Based Morphology achieves all of the desiderata in (1). Moreover, it does so with minimal, independently motivated machinery; the generalizations they correspond to follow from the basic sign-based architecture of the model without additional, ad-hoc stipulations.

Sign-Based Morphology is thus the only existing approach to the phonology-morphology interface that provides principled accounts of all the desiderata in (1).

1.1 Goals

In this section, I briefly discuss the desiderata in (1), and provide a road map to the rest of the study based on these desiderata.

Cyclic phonological effects are those in which a morphological subconstituent of a word seems to undergo phonology on its own. A good example is Mandarin Third Tone

Sandhi (Shih 1986, Sproat 1992), which changes a sequence of two third tones ($\check{C}\check{a}$) into a second tone followed by a third tone ($\acute{C}\check{a}$) within compounds and phrases. As Sproat note, in morphologically complex forms such as the compounds in (2), the tonal outcome depends on the direction of branching in the constituent structure:

(2) Sensitivity to direction of branching in Mandarin Third Tone Sandhi.

a) Right branching

[rǔan	[zǐ	cǎo]]	→	rǔanzícǎo
soft	purple	grass		Arnebia euchroma

b) Left branching

[[mǎ	wěi]	zǎo]	→	máwéizǎo
horse	tail	algae		kelp

Why does Tone Sandhi apply differently to these two forms, both of which contain a sequence of three third tones? Sproat points out that the answer must have something to do with the morphological structure of these forms. As a first step, note that, in both forms in (2), the inner morphological constituent is itself an independent word (3):

(3)	[zǐ cǎo]	→	zícǎo	‘Lithospermum Erythrorrhizon’
	[mǎ wěi]	→	máwěi	‘horse tail’

If the compounds in (2) are built out of the words in (3) instead of directly from their constituent roots, then the desired result is obtained simply by applying Third Tone Sandhi in the expected manner (4):

(4) a) Right branching

[rǔan	zǐcǎo]	→	rǔanzǐcǎo
soft	Lithospermum Erythrorrhizon		Arnebia euchroma

b) Left branching

[máwěi	zǎo]	→	máwéizǎo
horse tail	algae		kelp

We see that the inner two member compounds in (2) appear to be subject to phonology on their own. It is this kind of effect of morphological structure on phonology that is referred to as a cyclic phonological effect. Past theories of the phonology-morphology interface differ greatly in their handling of such effects. Accounts range from outright denial of the existence of cyclic effects (e.g., Bochner 1993, Karttunen 1993) to successive cyclic application of phonological rules from the inside out to fully built morphological (or even syntactic) structures (e.g., Chomsky and Halle 1968, Odden 1993) to a bottom-up derivational model of morphology in which phonology applies to the output of each morphological operation (e.g., Kiparsky 1982, Mohanan 1982, and also Anderson 1992), to edge alignment constraints applying to fully formed morphological structures (e.g., McCarthy and Prince 1993), to paradigmatic approaches to morphology that attempt to reduce cyclic effects to paradigm uniformity (e.g., Burzio 1994, Buckley 1995), to essentially syntagmatic approaches enriched with transderivational identity constraints (e.g., Kenstowicz 1995, Benua 1996, McCarthy 1996a). Sign-Based Morphology borrows insights from many of these approaches.

This study is devoted to exploring the types and properties of cyclic phonological effects found in natural languages. Chapter 2 investigates cyclic phonological effects of the kind just described, as well as *noncyclic* phonological effects. These are cases where intermediate constituents seem to be ignored by the phonology of the word in question, rather than being subject to phonology on their own as in (2). In chapter 2, I propose that such effects result from flat (that is, *n*-ary branching where $n > 2$) constituent structures. I then proceed to show how the same flat versus binary branching structures are motivated by independent morphological and phonological considerations in Turkish. This match between phonologically and morphologically motivated structures provides one of the strongest arguments in favor of Sign-Based Morphology. To my knowledge, no other theory of the phonology-morphology interface predicts such a correlation between morphologically motivated structures on the one hand and cyclic versus noncyclic phonological effects on the other.

Chapter 3 is devoted to exploring the relationship between Sign-Based Morphology and other approaches to morphology. In this chapter, I explicate the intellectual debt Sign-Based Morphology owes to past theories of morphology, and discuss how it incorporates their insights, and goes beyond them in both unifying those insights and avoiding possible pitfalls.

Chapter 4 investigates the status of level ordering in morphology. In this chapter, I focus on the empirical motivation for lexical strata and on the question of whether or not cophologies are extrinsically ordered, as is claimed in Lexical Phonology. In Sign-Based Morphology, level ordering is not the expected case, as I show in this chapter (see

also Inkelas and Orgun 1996), though it can be stipulated if necessary in any particular case, as in Orgun 1994c. The expectation in Sign-Based Morphology is for lexical levels (cophonologies) to be extrinsically unordered. This is consistent with the observations of various researchers cited in chapter 4 that level ordering is not supported empirically.

Chapter 5 investigates the status of Bracket Erasure effects in Sign-Based Morphology. The main insight behind Bracket Erasure (Pesetsky 1979) is that the internal morphological structure of forms is in general not available to the phonology or morphology. I show how Bracket Erasure effects follow directly from the local nature of feature percolation in constituent structures. In the rest of the chapter, I deal with challenges to Bracket Erasure effects. The investigation uncovers a previously unknown asymmetry between the amount of morphological and phonological information available to the grammar. The identity of the outermost morpheme in a form (in terms of constituent structure) is available to the grammar, but its location within the phonological string is not. This new generalization follows automatically from the architecture of Sign-Based Morphology by reference to lexical types that must independently be part of and independently needed inheritance hierarchy. As far as I can tell, this generalization is beyond even the descriptive capacity of any other approach to the phonology-morphology interface. Past approaches such as Lexical Phonology must give up Bracket Erasure completely in order to deal with data that require only a minor relaxation of the principle. Only Sign-Based Morphology makes just the right amount of information available. This generalization, handled straightforwardly in Sign-Based Morphology, is not even accessible in an approach that does not use type hierarchies (or similar devices for

expressing lexical patterns, such as the paradigmatic rules in Bochner's (1993) *Lexical Relatedness Morphology*).

Chapter 6 contains a discussion of phonology intended for the formally or computationally oriented linguist. Although I use Optimality Theory (Prince and Smolensky 1993) throughout this study, I devote this chapter to formal approaches to phonology such as those proposed by Bird 1990 and Scobbie 1991. I discuss the issue of one-level phonology (Bird and Ellison 1994, Bird and Klein 1994), often believed to be the only approach to phonology that is in the spirit of a declarative approach to grammar. I challenge this position by pointing out that two-level phonology is consistent with nonderivational approaches. The crucial observation is that percolation of information from daughter to mother nodes, which defines a two-level system, is already assumed in existing nonderivational theories of *syntax*. I argue that there is no principled reason to impose restrictions on the percolation of phonological information that are stricter than those imposed on other types of information. Furthermore, there are data that pose serious problems for one-level approaches to phonology. I present an illustrative example from Bengali.

I grant that, these points aside, there are independent, mostly computational, reasons to favor a one-level approach to phonology, and I provide a brief demonstration that most, if not all, of the insights developed in this study are available even if a one level theory of phonology is used.

The study ends in chapter 7 with a review of the desiderata for a theory of the phonology-morphology interface, all of which are satisfied by Sign-Based Morphology,

but no other theory. I also offer a summary of the new empirical generalizations that Sign-Based Morphology has allowed to surface.

1.2 Sign-based linguistics

The theory of the phonology-morphology interface developed in this study, Sign-Based Morphology, is a constituent structure-based theory. It shares its basic tools with all constituent structure-based approaches to linguistics. In particular, Sign-Based Morphology, like all constituent structure theories, assumes that both terminal and nonterminal nodes bear features. In all theories, for example, category features are assigned to nonterminal nodes. The relationship between a mother node's features and its immediate constituents' features plays a central role in Sign-Based Morphology. Due to this emphasis on nonterminal node features, the constituent structures might at first appear somewhat crowded. However, such constituent structures with significant amounts of information included in nonterminal nodes will be familiar from the work of Lieber (1980), to which Sign-Based Morphology owes many crucial insights.

The main innovation in Sign-Based Morphology is to include phonological information in nonterminal nodes as well as the usual syntactic and semantic information.² This move makes the theory internally more coherent by treating all kinds

² Although Lieber excluded phonological information from nonterminal nodes, inclusion of such information in nonterminal nodes is a standard feature of unification-based grammar formalisms such as Head-Driven Phrase Structure Grammar (HPSG; Pollard and Sag 1987, Pollard and Sag 1994), Construction Grammar (CG; Fillmore et al. 1988, Fillmore and Kay 1994, Fillmore and Kay 1996), and Lexical Functional Grammar (LFG; Kaplan and Bresnan 1982). However, the implications of this aspect of unification-based formalisms for cyclic phonological

of information alike (compare with theories such as Lieber's where phonology is singled out as the only kind of information that is borne exclusively by terminal nodes, while syntactic and semantic features are found on nonterminal as well as terminal nodes). It turns out that this natural move has a number of desirable empirical consequences. This work will be devoted to exploring these, as well as working out the formalism in some detail.

The inclusion of phonology in the types of information that nonterminal nodes bear is standard in unification-based grammar frameworks. Partly to acknowledge this debt, and partly to take advantage of the well-developed notational and formal apparatus developed in such frameworks, Sign-Based Morphology is couched in the unification-based grammar tradition. This school of thought includes frameworks such as Head-Driven Phrase Structure Grammar (HPSG; Pollard and Sag 1987, Pollard and Sag 1994), Construction Grammar (CG; Fillmore et al. 1988, Fillmore and Kay 1994, Fillmore and Kay 1996), and Lexical Functional Grammar (LFG; Kaplan and Bresnan 1982). The approach to morphology developed in this study is meant to be compatible with any of these frameworks (and, in fact, even with other grammatical frameworks that are not explicitly unification-based, including, perhaps surprisingly at first, approaches to morphology that reject constituent structures such as that of Anderson 1992; see section 3.2.2 for a discussion). I will, however, use a simplified HPSG-like notation in this work for the sake of concreteness.

effects has not been addressed in the unification-based literature. Sign-Based Morphology remedies this deficiency.

The basic object of grammatical description in a unification-based theory is a Saussurean sign, a pairing of form (phonology) and meaning (semantics). Signs are modeled by feature structures. A feature structure is a collection of attribute-value pairs. An attribute value pair consists of an attribute name (written in small capitals on the left hand side) and a value (written on the right hand side). Values that are unspecified are indicated by writing the name of the attribute in lower case italics in place of a value.³ Values are themselves feature structures, except for atomic values, which have no internal structure. Atomic values are written in lower case italic letters. Examples of feature structures are shown in (5):

(5) a) [CAT *noun*]

b)
$$\left[\begin{array}{l} \text{SYNSEM} \\ \text{PHON} \end{array} \left[\begin{array}{l} \text{CAT} \quad \textit{noun} \\ \text{AGR} \quad \left[\begin{array}{l} \text{PERSON} \quad \textit{third} \\ \text{NUMBER} \quad \textit{plural} \end{array} \right] \\ \text{SEM} \quad \textit{'they'}$$

c) Generic sign:⁴

$$\left[\begin{array}{l} \text{SYNSEM} \\ \text{PHON} \end{array} \begin{array}{l} \textit{synsem} \\ \textit{phon} \end{array} \right]$$

³ We will see in section 5.2.3 that this notation refers to a type in an inheritance hierarchy.

⁴ In HPSG, the usual assumption is that the value of the PHON attribute is a list of phonological units. Following Bird and Klein 1994, we may assume that lists can be parameterized and that the type *phon* is an abbreviation for *list(segment)*, that is, a list of segments. See Bird and Klein 1994 and Walther 1995 for a discussion of how metrical structure and autosegmental representations can be incorporated into such a system.

The examples in (5b,c) illustrate some of the structure of the basic sign, which consists of a SYNSEM attribute (syntactic and semantic information) and a PHON attribute (phonological information). The notation SYNSEM|AGR|PERSON *third* is a useful abbreviation for [SYNSEM [AGR [PERSON *third*]]]. I will use this abbreviatory notation quite extensively.

The syntactic and semantic features will be highly abbreviated and informal in this study for the sake of conciseness. In particular, English glosses will generally be used to represent the value of the attribute SYNSEM|SEM.

Constituent structures are a statement of relations between signs. In HPSG work, constituent structures are notated within a feature structure by using a list-valued attribute called DTRS (daughters), whose value consists of a feature structure with attributes representing the daughter nodes. An example is given in (6a), where the path SYNSEM|SEM is abbreviated further to SEM, and where the value of the DTRS attribute is represented as a list of the immediate constituents of the node that bears this attribute. In this study, I will use the equivalent, but visually more attractive, tree notation (6b):⁵

⁵ The tree notation is somewhat less precise than the feature structure notation, since in HPSG, different daughters are often represented by different attributes (such as HEAD-DTR, SUBJ-DTR), a distinction that is lost by using the tree notation. Since this loss of precision has no bearing on the issues discussed in this work, using the visually more appealing tree notation will do no harm

(6) a) HPSG notation

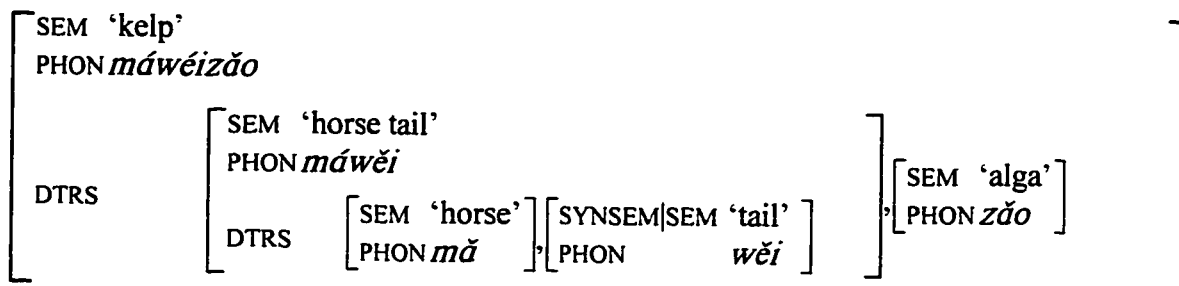

b) Tree notation

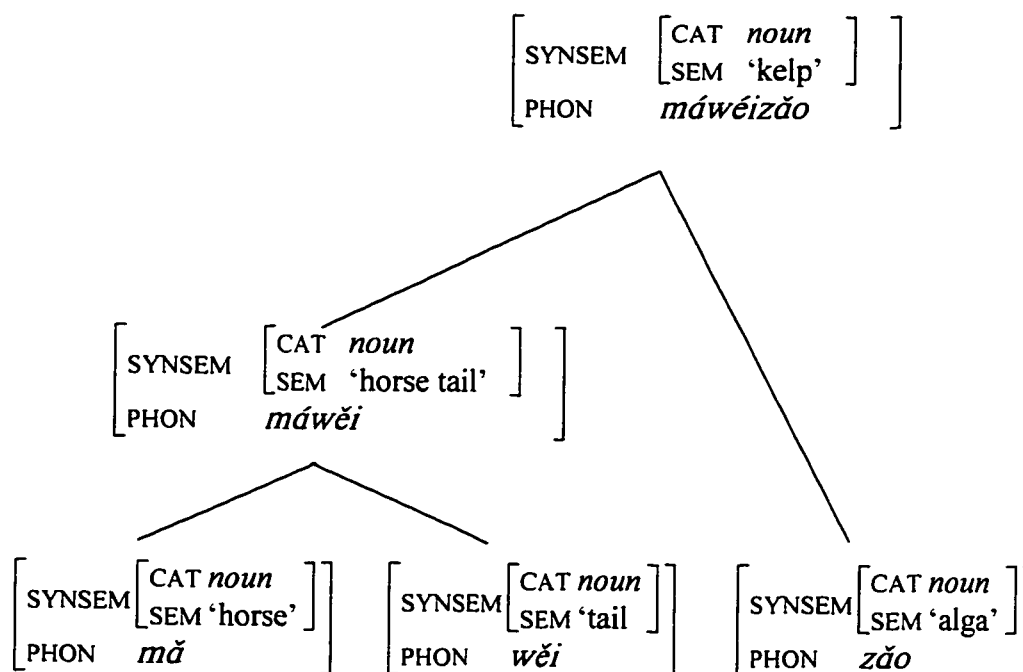

Other attributes will be introduced as they are needed. For a more detailed and formal discussion of HPSG, refer to Pollard and Sag 1994.

1.3 Optimality Theory

Phonological analyses in this study will be stated in the framework of Optimality Theory (Prince and Smolensky 1993). In particular, I will use the two-level version of Optimality

Theory proposed by McCarthy and Prince 1994a,b. In this section, I present a brief introduction to the basics of Optimality Theory.

An Optimality-theoretic grammar consists of ranked and violable constraints. Violation of a constraint is possible if and only if such violation is necessary in order to better satisfy a higher-ranking constraint. Given an input, the grammatical output is the one that best satisfies the ranked constraint system among an infinite set of candidate output forms. Consider, for example, [ə] epenthesis in English plural forms (*dagz* ‘dogs’ versus *bædʒəz* ‘badges’).⁶ Assume for the sake of demonstration that the underlying form of the plural suffix is /z/. Assume, following Borowsky 1989 that the constraint responsible for [ə] epenthesis is some version of the Obligatory Contour Principle (OCP; Leben 1973, Goldsmith 1976), prohibiting two adjacent stridents. We also need constraints against deletion (MAX) and insertion (DEP)⁷ of phonological material. The constraints are summarized in (7):

⁶ All English data reflect the speech of a native of California.

⁷ MAX (maximality) and DEP (dependence) are taken from McCarthy and Prince 1995. Unlike the original version of Optimality Theory in Prince and Smolensky 1993 in which only the output phonological string (but not the input string) was visible to the grammatical constraint system EVAL, in this version the phonological mapping relates two phonological strings, input and output. Deletion and epenthesis correspond to the absence of an element of one string in the other string. MAX and DEP assign violation marks for this. It may be noticed that MAX and DEP are duals (mirror images) of each other. This point is implicit in McCarthy and Prince’s definition of these constraints. In Orgun 1996a I made this point explicit by proposing a family of constraints with the structure CORR(string1, string2, X) requiring for every phonological element X in string 1 to be a corresponding element in string 2. MAX is then CORR(input, output, X), and DEP is CORR(output, input, X).

- (7) OCP Two adjacent stridents are prohibited
 DEP Do not insert phonological material
 MAX Do not delete phonological material

OCP must outrank DEP, since epenthesis applies in order to prevent OCP violations. Similarly, MAX must outrank DEP; otherwise, deletion would have been the chosen repair. We cannot establish a ranking between MAX and the OCP, since the two never conflict in the data we are considering.

- (8) MAX, OCP » DEP

The mapping of the input form to the winning candidate is illustrated by using a constraint tableau (9), (10):

(9)

/dag-z/	MAX	OCP	DEP
☞ dagz			
dag	*!		
daz	*!		
dagəz			*!

(10)

/bædʒ-z/	MAX	OCP	DEP
bædʒz		*!	
bædʒ	*!		
bæz	*!		
☞ bædʒəz			

The input form is shown in the upper left-hand cell. Below this, the candidate output forms that we are considering are listed (even though the candidate set is infinite—it is the set of all possible phonological strings—relatively few candidates are of interest to the

linguist). The winning candidate, which is the actual grammatical output form, is indicated by a pointing hand.⁸ The constraints that constitute the grammar are listed along the top. A broken line between columns indicates lack of evidence for crucial ranking between the constraints so separated. A solid line indicates that the left hand constraint outranks the right hand one. An asterisk in a cell indicates a constraint violation. Fatal violations are indicated by an asterisk followed by an exclamation mark. Cells that are irrelevant to determining the grammatical output are shaded. The sole purpose of the pointing hand, exclamation mark, and shading is to make the tableau easier to read. The conventions do not form part of the formalism.

1.4 What does “nonderivational” mean?

Current years have witnessed a growing trend towards approaches to grammar that are said to be nonderivational. However, there is little if any explicit discussion in the literature of what makes a theory derivational or nonderivational. One of the main claims of Sign-Based Morphology is that it does away with the myth that cyclic phonology is necessarily derivational. To make it clear what this means, I present an explicit discussion of what exactly it means for a theory to be nonderivational. I include helpful analogies that might make the issue clearer.

⁸ The following notational conventions will be used in later chapters: an ungrammatical form incorrectly predicted by the constraint system to be the optimal output will be indicated by a bomb symbol (☛). The actual grammatical form will then be indicated by a pointing hand in parentheses, following Prince and Smolensky 1993.

1.4.1 Derivational models

In a derivational model, the order in which operations are carried out has an effect on the ultimate outcome. This property alone is what distinguishes derivational models from nonderivational ones.

A good example of a derivational model is rotation through ninety degrees around various axes. To illustrate this, imagine a book (11):

(11)

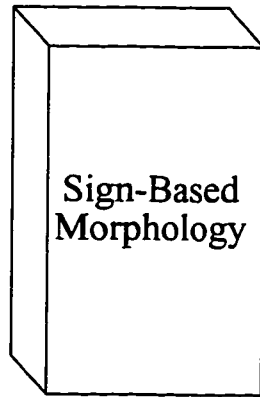

Let us define two rotations. The first is a rotation through ninety degrees around an axis perpendicular to the page (12):

(12) R1:



The second function we define is a rotation through ninety degrees around a horizontal axis parallel to the page (13):

(13) R2:

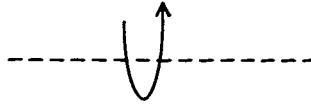

If we apply R1 followed by R2, we obtain the result in (14):

(14)

Initial state:

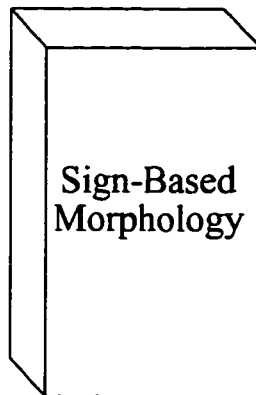

Output of R1:

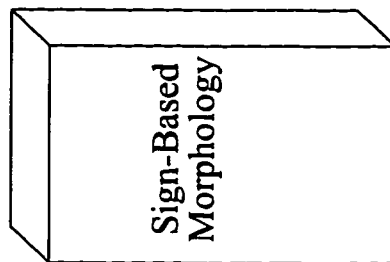

Final state (output of R2):

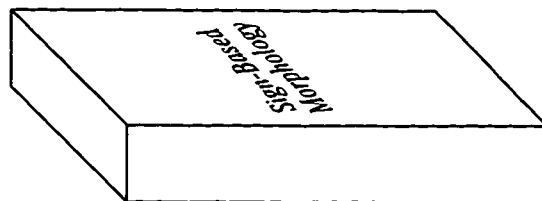

When we carry out the rotations in the opposite order (R2, then R1), we obtain a different result (15):

(15)

Initial state:

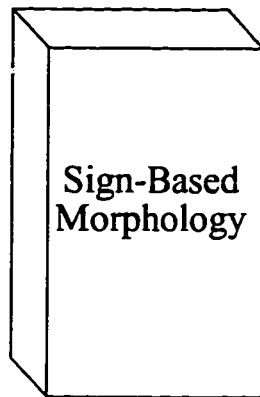

Output of R2:

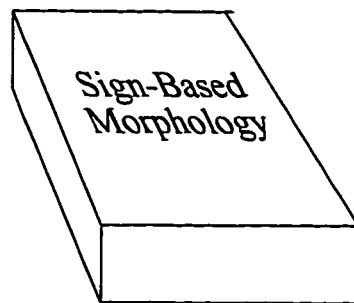

Final state (output of R1):

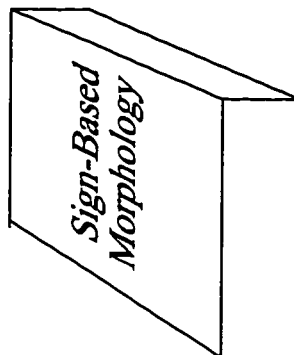

Since the order in which the rotation functions are applied has an effect on the ultimate outcome, rotation through ninety degrees around different axes is derivational.

A familiar derivational theory of phonology is the SPE model, where the surface output crucially depends on the order in which rules are applied.

1.4.2 Nonderivational models

In nonderivational models, the ultimate outcome is independent of the order in which operations are performed. If desired, an interpretation in which all operations are carried out at the same time, in parallel, is possible. In many models, it is also possible to conceive of the system as imposing constraints on the object being described, rather than as performing operations. Regardless of which of these conceptions is adopted, the crucial property of nonderivational models is that the outcome never depends on the temporal order in which operations are performed.

Building a Lego® or Tinker Toy® model is a nonderivational system. As long as the pieces are connected in the same configuration, it is irrelevant in which order the connections are established. Imagine, for example, that we have three bricks of various lengths, out of which we build a step pyramid. The bricks are shown in (16):

(16)

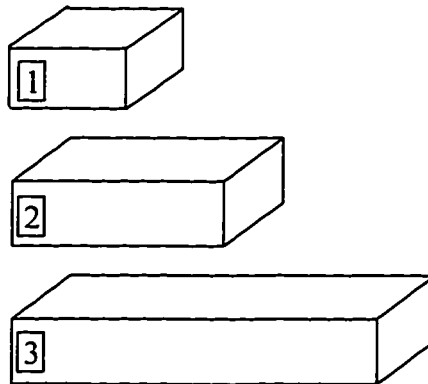

The two operations we define are:

- i) Place brick 1 on top of brick 2
- ii) Place brick 2 on top of brick 3.

If we apply operation (i) before operation (ii), we have the derivation in (17):

(17) Output of operation (i):

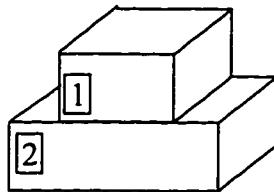

Output of operation (ii):

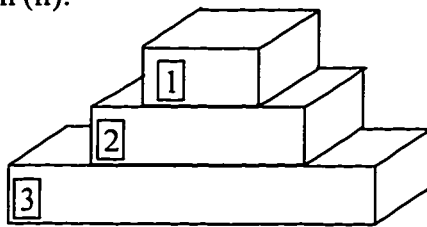

If we apply the operations in the opposite order, we still get the same result, as shown in

(18):

(18) Output of operation (ii):

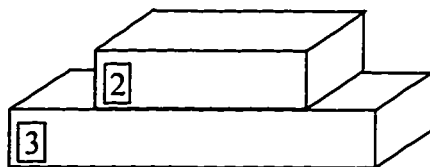

Output of operation (i):

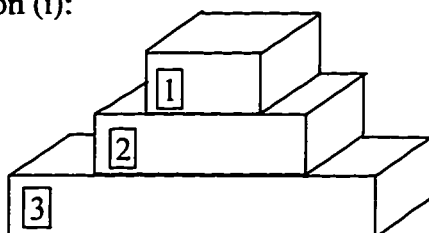

Building Lego models is nonderivational since the surface outcome is independent of the order in which building operations are carried out. Notice that the final outcome could also have been described in terms of static constraints:

- i) Brick 1 is on top of brick 2
- ii) Brick 2 is on top of brick 3.

It is a general property of nonderivational models that their output can be described in terms of wellformedness constraints instead of in terms of instructions for building the output procedurally.

Another example of a nonderivational model is function composition. Consider, for example, the functions in (19):

(19) $f(x) = 2x$

$$g(y) = y + 1$$

Suppose we want to compute $g(f(47))$. If we apply f to 47 first, then apply g to the result, we obtain the following:

$$(20) \quad f(47) = 94 \\ g(94) = 95$$

Now, suppose we compute $g(f(x))$ analytically first, then apply this new function, which I call h , to 47. We then have the following derivation:

$$(21) \quad h(x) \equiv g(f(x)) = g(2x) = 2x + 1 \\ h(47) = 95$$

The ultimate outcome of function composition is independent of the order in which composition and variable substitution are performed. The model is therefore nonderivational.

A familiar linguistic example of a nonderivational model is constituent structure definition. Suppose for example that we have the following phrase structure constructions:

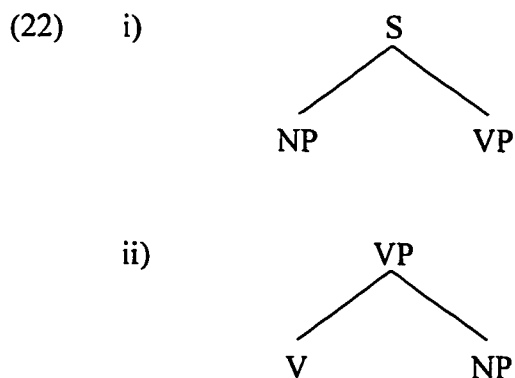

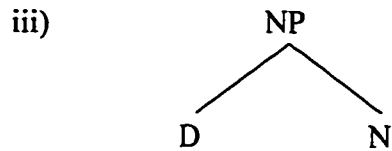

Regardless of the order in which we combine these constructions, they will license the following constituent structure tree:

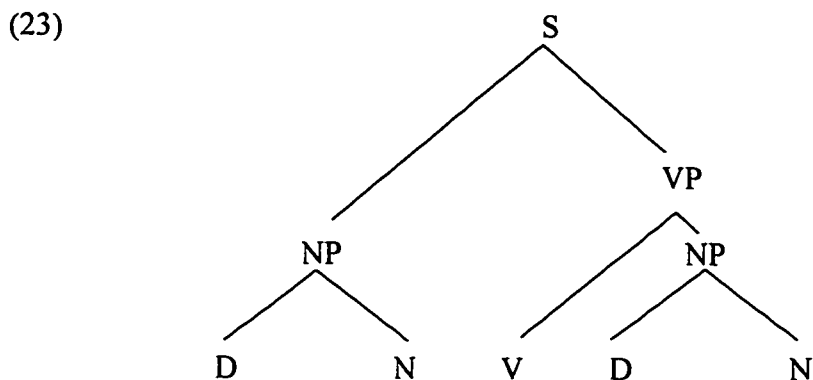

Since the outcome is independent of the order in which we combine our constructions, the model is nonderivational. Not surprisingly, we can, if desired, view our constructions as constraints on wellformed constituent structures rather than as procedural instructions for building one.

1.4.3 Why sign-based linguistics is nonderivational

Sign-based linguistics is based on constituent structures. We have just seen that licensing constituent structures is a nonderivational affair. The distinguishing aspect of sign-based theories is that they assume that all nodes in a constituent structure contain semantic and

phonological information. The question we must address is whether this fact makes sign-based theories derivational.

The dependency between mother and daughter node features in a sign-based constituent structure can be represented by using functions as in (24):

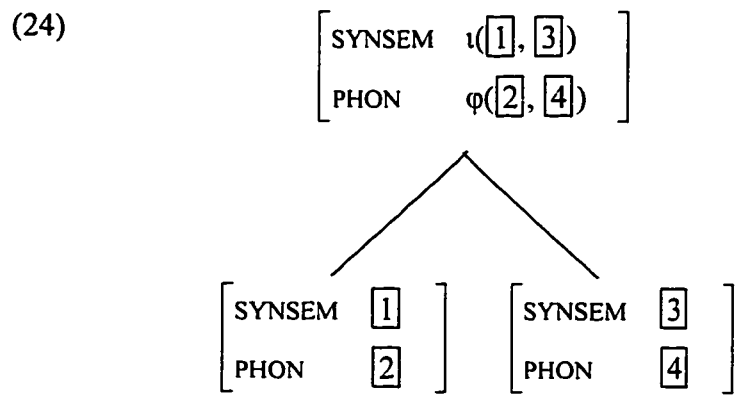

In a hierarchical constituent structure, some function composition will be called for. For example, consider the constituent structure in (25) with three levels of constituents:

(25)

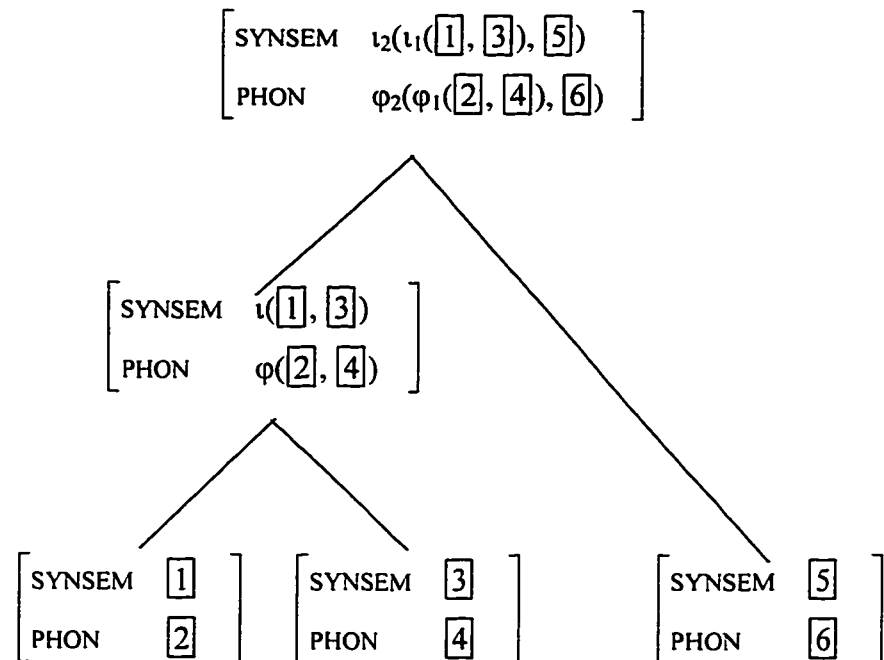

Since constituent structure building is nonderivational and function composition is also nonderivational, we can conclude that sign-based linguistics is also nonderivational (assuming, of course, that the functions ι and φ are defined nonderivationally).

One of the main claims of this work is that sign-based representations such as the one in (25) automatically derive cyclic phonological effects. Since I have just demonstrated that such theories are nonderivational, we can consider the belief that cyclic phonology is necessarily derivational a myth.

1.4.4 Advanced formal considerations

One last issue needs to be addressed concerning nonderivationalism. It turns out that any computation that can be done, can be done nonderivationally. This is achieved by reifying each stage of the derivation as a distinct representation. One can then replace derivational operations with statements (constraints) on relationships between these representations.

For example, Johnson (1972) has noted that the traditional SPE derivation can be given a nonderivational interpretation in this way. The traditional derivation assumes that a single phonological string is successively deformed by phonological rules that apply in a particular temporal order. After the last rule has applied, the resulting string is submitted to the phonetic interpretation module. This model is depicted in (26):

$$(26) \quad UR \rightarrow \boxed{\text{rule 1}} \rightarrow \boxed{\text{rule 2}} \rightarrow \dots \rightarrow \boxed{\text{rule } n} \rightarrow SR$$

In the nonderivational interpretation, the temporal stages are replaced by separate levels of representation, and the rules with correspondence constraints holding between those representations (27):

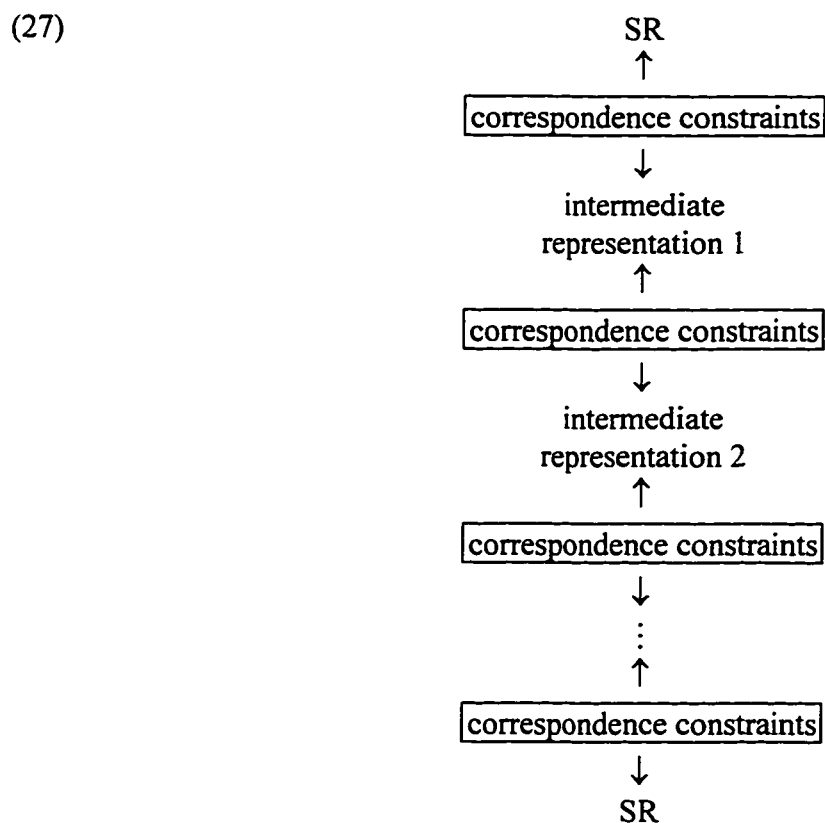

Given that every computation can be performed nonderivationally in this trivial and unenlightening manner, one is tempted to ask what significance it has for a theory to be nonderivational. The general answer is that if all the representations used in a nonderivational theory are independently motivated, that theory can be considered satisfactory. If nonderivationalism is achieved only by proliferating levels in an ad-hoc manner, then something is wrong with the theory. A derivational theory might be undesirable, but so is one that uses ad-hoc representations that have no independent motivation.

Let us evaluate Sign-Based Morphology from this perspective. In Sign-Based Morphology, a nonderivational model of phonology-morphology interleaving is achieved by utilizing constraints that relate mother nodes to their immediate constituents. Constituent structures are of course assumed independently of the need to deal with cyclic phonological effects. They are not introduced just to deal with cyclicity. Thus, the only tool used in order to deal with cyclic phonology, namely constituent structures, is amply motivated theory internally.

The intermediate nodes in a Sign-Based Morphological constituent structure are also justified by the fact that they each represent an independent lexical entry. Their existence is thus established beyond doubt. Consider terminal nodes first. These represent morphologically simple lexical forms, that is, roots.⁹ Next, consider nonterminal nodes. These represent morphologically complex lexical entries.

⁹ Here, I am assuming that affixes are not represented as terminal constituents. See section 3.2.2 for a discussion of this point.

Thus, we have seen that:

- i) The general mechanism of using constraints relating nodes in a constituent structure does not introduce ad-hoc tools, since constituent structures are motivated independently of phonology-morphology interleaving.
- ii) The specific intermediate constituents used in Sign-Based Morphology are not ad-hoc entities, since they all represent lexical entries whose existence cannot be doubted.

Thus, unlike the unnatural and ad-hoc nonderivational interpretation of SPE, which reifies a large number of phonological representations that have no empirical, theoretical, or cognitive justification, the nonderivational interpretation of Sign-Based Morphology given in section 1.4.3 is the natural and principled interpretation.

As I have remarked earlier, the overall theory will be nonderivational provided that the functions that describe feature percolation are nonderivational. Although Optimality Theory, which is only one of the many nonderivational theories of phonology available today, is used in phonological analyses throughout this study, the theory of the morphology-phonology interface which is developed here is meant to be independent of the phonological theory assumed. Any nonderivational two-level theory of phonology may be used. As I discuss in chapter 6, even one-level theories of phonology permit most, if not all, of the desirable consequences of Sign-Based Morphology to emerge.

Chapter 2. Cyclic and noncyclic phonological effects

A proper theory of the phonology-morphology interface must account for apparent cyclic phonological effects as well as noncyclic phonological effects. Cyclic phonological effects are those in which a morphological subconstituent of a word seems to be an exclusive domain for some phonological rule or constraint. In this chapter, I show how Sign-Based Morphology can handle noncyclic as well as cyclic phonological effects. Furthermore, Sign-Based Morphology, unlike other theories of the phonology-morphology interface, relates the cyclic-noncyclic contrast to independently motivatable morphological structures.

2.1 Turkish prosodic minimality

The example in this section is a disyllabic minimal size condition that some speakers of Standard Istanbul Turkish impose on affixed forms (Itô and Hankamer 1989, Inkelas and Orgun 1995). The examples in (28b) show that affixed monosyllabic forms are ungrammatical for these speakers (unaffixed monosyllabic forms are accepted (28a), as are semantically similar polysyllabic affixed forms (29b).

(28) a)	do:	‘musical note C’	b)	*do:-m	‘C-1sg.poss’
	je	‘eat’		*je-n	‘eat-pass’
(29) a)	sol ⁱ	‘musical note G’	b)	sol ⁱ -ym	‘G-1sg.poss’
	kaza:	‘accident’		kaza:-m	‘accident-1sg.poss’
	jut	‘swallow’		jut-ul	‘swallow-pass’
	tek ⁱ mel ⁱ e	‘kick’		tek ⁱ mel ⁱ e-n	‘kick-pass’

What happens when more suffixes are added to the forms in (28b) to bring the total size to two syllables? It turns out that nominal forms with additional affixes are still ungrammatical regardless of the total size, as shown by the data in (30).

- | | | | | |
|------|--------|--------------|------------|-------------------|
| (30) | *do:-m | ‘C-1sg.poss’ | *do:-m-u | ‘C-1sg.poss’ |
| | *re:-n | ‘D-2sg.poss’ | *re:-n-den | ‘D-2sg.poss-abl’ |
| | *fa:-m | ‘F-1sg.poss’ | *fa:-m-sa | ‘F-1sg.poss-cond’ |

These forms suggest that the disyllabic minimal size condition is enforced cyclically. That is, assuming a binary left-branching structure for suffixed forms, each suffixed subconstituent must satisfy the minimal size condition.

- (31) [[[root] suffix]_{min σσ} suffix]_{min σσ}

As we have seen in section 1.2, cyclic phonological effects result from the enforcement of phonological constraints on each constituent. If we assume that every nonterminal node is subject to the disyllabic condition, the rest follows simply from the constituent structure. Example (32) schematically shows the disyllabic minimal size constraint.¹⁰ The intended

¹⁰ The constraint can be stated more formally if type hierarchies are used (see section 5.2.3 for discussion). We can then simply define a type *nonterminal node* (we independently need this to distinguish terminal nodes, which have immediate constituents from nonterminal nodes, which do not). Then, the disyllabic minimal size condition can be part of the definition of the type *nonterminal node*: *nonterminal node* ⇒ PHON /σσ.../. I abstract away here from the issue of representing metrical structure in a feature-based formalism such as HPSG. See Bird and Ellison 1994 and Walther 1995 for some discussion.

interpretation of this construction is that any node that is morphologically complex must contain at least two syllables.¹¹

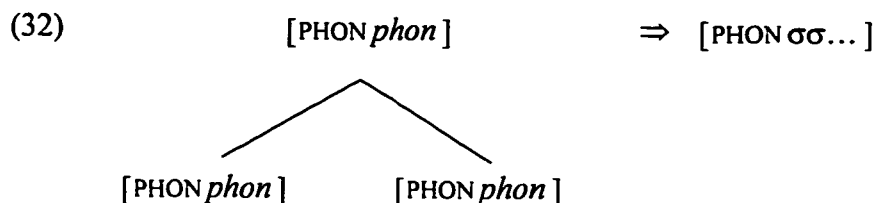

The structure for the ungrammatical subminimal form *do:-m* ‘my C’ is shown in (33):

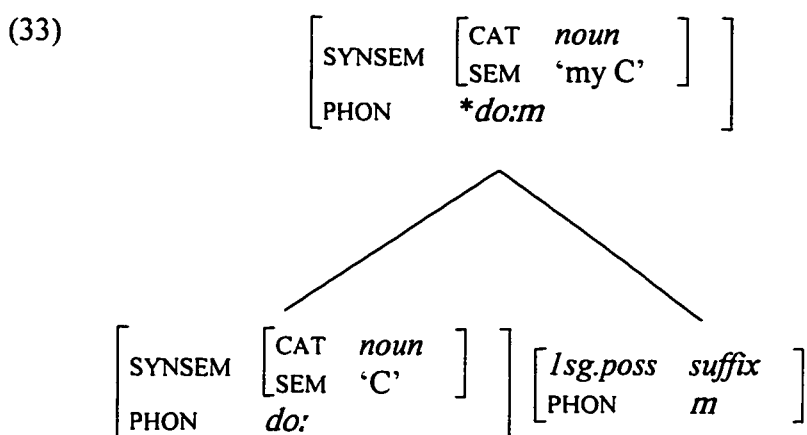

This form is ungrammatical because the mother node contains only one syllable, and therefore violates the requirement that all nonterminal nodes contain at least two syllables. This violation is indicated by an asterisk preceding the phonological string of the mother node.

Example (34) shows the structure for the supraminimal form **do:-m-u* ‘my C (acc.)’, which is ungrammatical even though it contains two syllables.¹²

¹¹ I assume here that affixes are represented as terminal constituents. This assumption is not crucial, but makes the presentation more transparent.

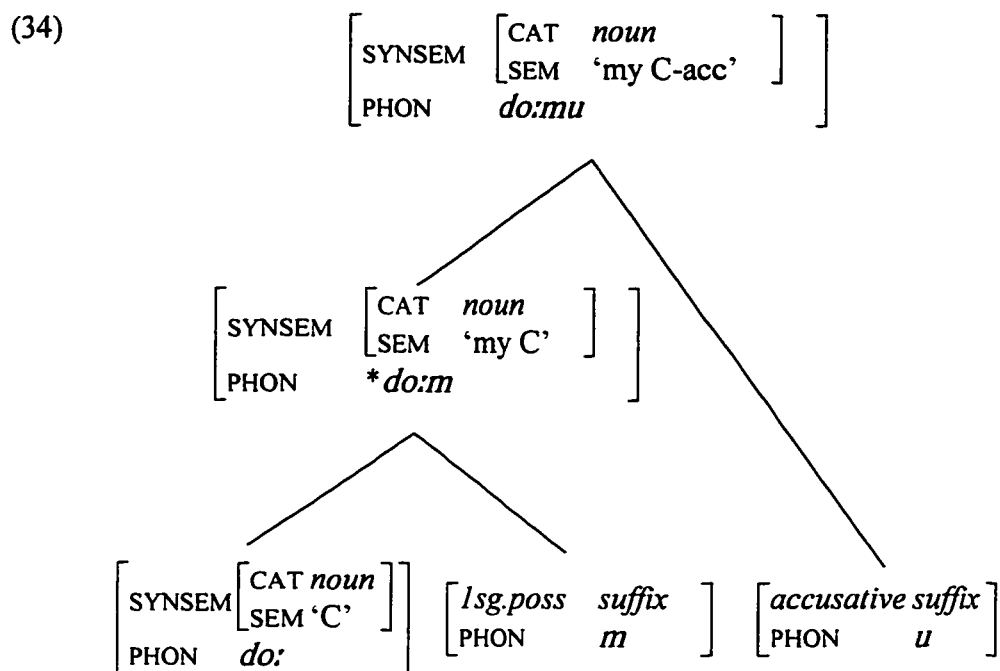

This form is ungrammatical because it contains a nonterminal node (namely the intermediate node **/do:-m/*) that contains only one syllable. This example illustrates one of the basic principles of sign-based linguistics: a constituent structure is well-formed if and only if all nodes in it are well-formed. In other words, a constituent structure represents a grammatical construct of the language if and only if:

- a) all nonterminal nodes are related to their daughters in a way licensed by universal percolation conventions and language or construction specific constraints (including the appropriate phonological mapping), and

¹² I am using the SYNSEM|SEM attribute to provide English glosses, not to make claims concerning semantic representation. I am not claiming, for example, that “accusative” is part of the semantic representation of the accusative suffix.

b) all nodes satisfy all constraints imposed on nodes of their type (this is akin to the requirement in GPSG that all local trees must be well-formed).¹³

In (34), the intermediate node */do:-m/ violates clause (b), because it fails to satisfy a constraint (disyllabic minimality) imposed on nonterminal nodes.

The apparent cyclic application of the minimal size condition thus follows from the requirement that every local tree be wellformed. In the minimality case, this translates into a requirement that every nonterminal node contain two syllables. Even when the whole word contains the required two syllables, it may still be ungrammatical because there is a subconstituent that does not meet the requirement. Another possible interpretation of this analysis is the following: cased nouns are built out of bare or possessed noun stems. In the case of **do:-m-u*, there is no possessed noun stem *do:-m* (this being ruled out by the disyllabic minimal size condition). Therefore, there is nothing available to apply the case construction to.

For comparison, example (35) shows the constituent structure for the grammatical form *sol^l.ym-y* ‘my G-acc’:

¹³ A local tree is a mother node plus its immediate constituents.

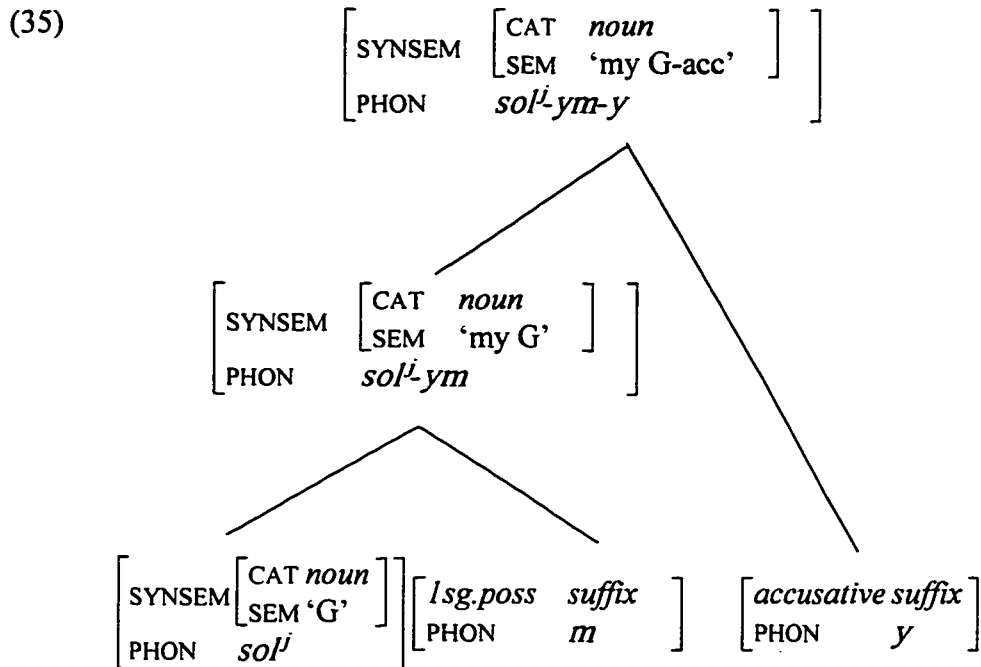

In this structure, all nonterminal nodes satisfy the minimal size condition. This is therefore a grammatical form of Istanbul Turkish.

We see that cyclic phonological effects are an automatic consequence of using constituent structures in morphological description. The only tools that are needed to account for cyclic phonological effects are:

- i) Constituent structures. These are a standard assumption in many linguistic theories.
- ii) A mechanism of feature percolation whereby the features of a mother node are related to the features of its daughters. All constituent structure-based theories assume some degree of feature percolation.

It is thus fair to say that cyclic phonological effects come for free—no additional stipulation needs to be made to derive them once a constituent structure-based

understanding of linguistics is adopted.¹⁴ This conclusion is largely independent of the particular theory of phonology assumed. As long as all nodes (including nonterminal nodes) bear phonological information, and the information in a mother node is related in some fashion to the information in its daughters (as must be the case in *any* theory), cyclic phonological effects follow.

We have seen that the apparent cyclic application of the disyllabic minimal size condition is handled quite successfully and elegantly in Sign-Based Morphology. A quite different situation obtains in verbs. Verbal subminimal forms do become grammatical when more suffixes are added to bring the total size to at least two syllables.

(36)	*je-n	‘eat-pass’
	je-n-ir	‘eat-pass-imprf’
	je-n-di	‘eat-pass-past’
	je-n-me-miʃ	‘eat-pass-neg-evid’

In these forms, the minimal size condition seems to be enforced noncyclically. That is, only the whole word is subject to the minimal size condition. Intermediate suffixed stems are not required to be disyllabic.

Following Orgun (1994b,c, 1995a,b, 1996b) I use flat constituent structures to derive noncyclic phonological effects (see also Cole and Coleman 1993 for a similar approach). Accordingly, the verbal forms in (36) must have a flat structure (I show in

¹⁴ There are, of course, linguistic theories that do not assume constituent structures, at least not for affixational morphology. Of those, the realizational approach of Anderson (1992) is quite similar in spirit to Sign-Based Morphology, as I show in section 3.2.2. In particular, realizational morphology, like Sign-Based Morphology, accounts for cyclic phonological effects at no extra cost. Thus, the observation that

section 2.2 that these flat versus branching structures find independent morphological motivation, providing striking support for the theory). The structure for the ungrammatical subminimal form **je-n* is shown in (37):

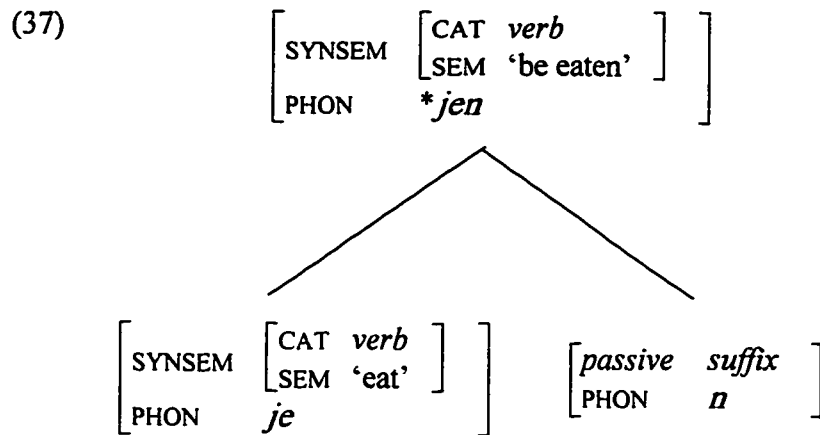

This form is ungrammatical because the mother node contains only one syllable, violating the disyllabic minimal size condition. Example (38) shows the structure for the grammatical form *jut-ul* 'swallow-pass' for comparison:¹⁵

handling cyclic phonology does not add and complexity to a linguistic theory is independent of whether constituent structures are to be used.

¹⁵ The allomorphy of the passive suffix (*-n* ~ *-n*) is conditioned by the final segment of the stem. *-n* attaches to vowel-final stems and [l] final stems (with an epenthetic vowel in the latter), while *-n* attaches to all others.

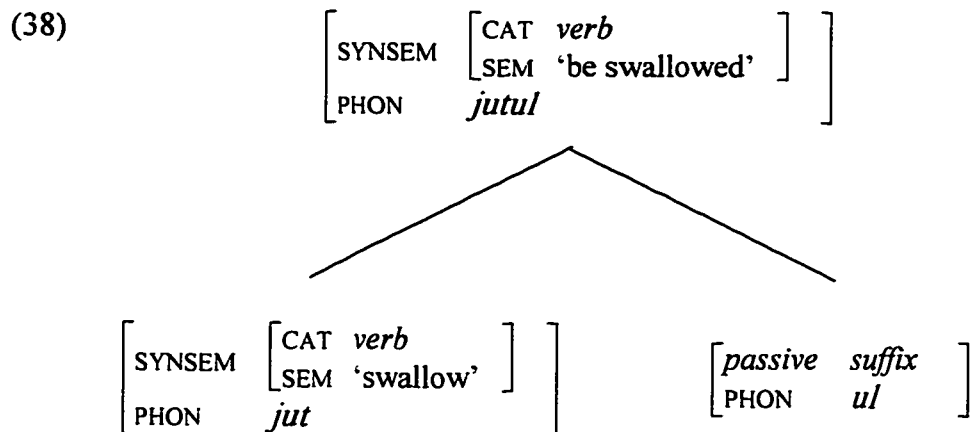

Recall that subminimal verbal forms can be “repaired” by adding further suffixes, suggesting that the minimal size condition is enforced noncyclically in these forms. We account for this by assuming a flat structure, as shown in (39):

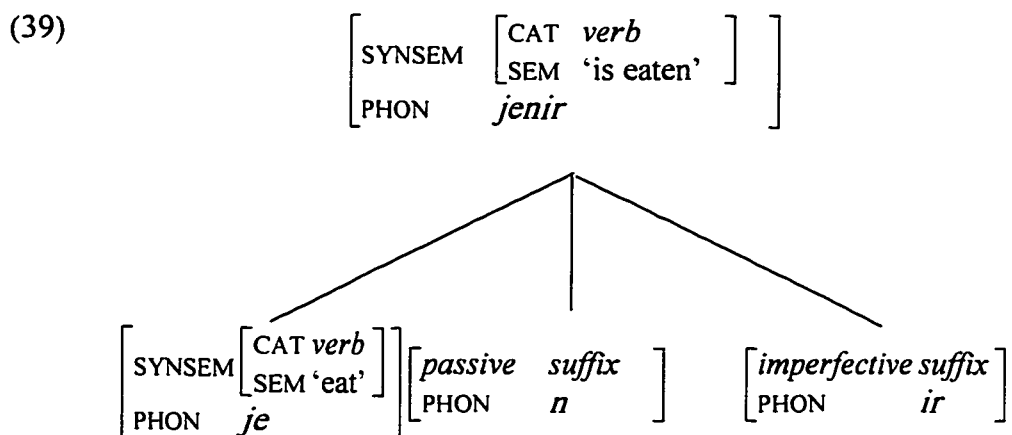

In this constituent structure, there are no nonterminal nodes that violate the minimal size condition. The structure therefore represents a grammatical construct of Istanbul Turkish, namely the form *jenir* ‘is eaten’.

At this point, we must ask whether there is any independent linguistic evidence for the flat versus branching structures used in this section. It turns out that there is, as shown by Orgun 1995a,b. I summarize the relevant data below.

2.2 Suspended Affixation

Allowing both flat and branching structures raises a methodological question: in the absence of evidence for either, are we to assume flat or branching structures? I suggest assuming flat structures as a null hypothesis, and use branching structures only when motivated by positive evidence.^{16,17} It is likely that this is the strategy that will converge on the desired result most quickly, since wrong branching patterns will never need to be considered. Accordingly, in this section, I will present independent positive evidence for the binary branching structure found in the nominal forms in (30). The lack of evidence for branching structures in the verbal forms in (36) will be taken to be sufficient to assume flat structures for those forms.

The evidence for branching comes from a construction called Suspended Affixation by Lewis (1967). In this construction, when two suffixed words are conjoined,

¹⁶ This is of course related to the issue of whether cyclic or noncyclic phonology is the default assumption. My proposal amounts to claiming that noncyclic phonology is the default, and cyclic phonology is to be used only when there is positive evidence. This proposal is similar in spirit in current approaches (for example, Prince and Smolensky 1993), although I differ from them in allowing cyclic phonological effects to be sufficient to motivate branching morphological structures.

¹⁷ It is not clear to me at this point whether these same considerations are valid for syntax as well as for morphology.

suffixes that have scope over both conjuncts may optionally be omitted from the first conjunct, and realized only on the second conjunct.¹⁸

An example is shown in (40a), where the two nouns *suhhat* ‘health’ and *a:fijet* ‘well being’ are conjoined, and the locative suffix, which has scope over both of them, is found only once at the end of the conjoined phrase instead of on both conjuncts. Example (40b) is similar, with the plural (*-l’er*) and possessive (*-i*) suffixes having scope over the conjuncts *adʒu* ‘sorrow’ and *sevintʃ* ‘joy’. Further examples can be found in Lewis (1967), Underhill (1976), and Inkelas and Orgun (1994).

- (40) a) *suhhat ve a:fijet-te*
 health and well-being-loc
 ‘in health and well-being’
- b) (*halk-un*) [*adʒu ve sevintʃ*]-*l’er-i*
 people-gen sorrow and joy-pl-3sg.poss
 ‘the people’s sorrows and joys’

Example (41) shows the null hypothesis for the structure of this construction. I assume that the constituent structure is as implied by the scope relations, with the locative suffix attached to the whole conjoined NP.

- (41) [[*suhhat ve a:fijet*] -te]
 [[*adʒu ve sevintʃ*] -l’er-i]

There are initially puzzling restrictions on the combinations of affixes that Suspended

¹⁸ The following summary has been adopted from Orgun 1995b.

Affixation can target. Example (42b) shows that it is acceptable not to suspend any affixes at all. Here, all suffixes are realized on both conjuncts. As seen in (42a), it is possible to suspend ALL eligible affixes. Here, the plural suffix *-l'er*, the possessive *-im* (1st person singular) in the first example, and *-i* (3rd person singular) in the second example, and the accusative suffix *-i* (in the first example) are all suspended.

(42) a) No affixes suspended:

k^jedi-l'er-im -i ve k^jøpek^j-l'er-im -i
 cat -pl -lsg.poss -acc and dog -pl -lsg.poss -acc

ad³u -lar -u ve sevint^f -l'er-i
 sorrow-pl -3sg.poss and joy -pl -3sg.poss

b) All affixes suspended:

[k^jedi ve k^jøpek^j]-l'er-im -i
 [cat and dog]-pl -lsg.poss -acc
 'my cats and dogs (acc)'

[ad³u ve sevint^f]-l'er-i
 [sorrow and joy]-pl -3sg.poss

Example (43) shows the promised puzzling restrictions on Suspended Affixation. In (43a), we see that it is possible to suspend just the accusative suffix *-i* while realizing the plural and possessive suffixes on both conjuncts. Examples (43b,c) show that it is not possible to realize the plural suffix *-l'er* on both conjuncts while suspending the possessive (and accusative) suffixes.

(43) Suspension of some but not all affixes

- a) [k^jedi-l^jer-im ve k^jøpek^j-l^jer-im]-i
-pl -1sg.poss]-acc
- b) *[k^jedi-l^jer ve k^jøpek^j-l^jer]-im -i
-pl -pl]-1sg.poss-acc
- c) *[adʒu-lar ve sevintʃ-l^jer]-i
-pl -pl]-3sg.poss

Our task is to account for this inseparability of the plural and possessive suffixes in Suspended Affixation. That is, we need to find a formal account of the observation that the plural and possessive suffixes are either both realized on all conjuncts or both suspended.

I offer an analysis of this seemingly strange restriction in terms of constituent structure. I claim that the plural and possessive suffixes form a flat (ternary branching) structure with the base they attach to, as shown in (44), rather than a binary branching hierarchical structure as in (44).

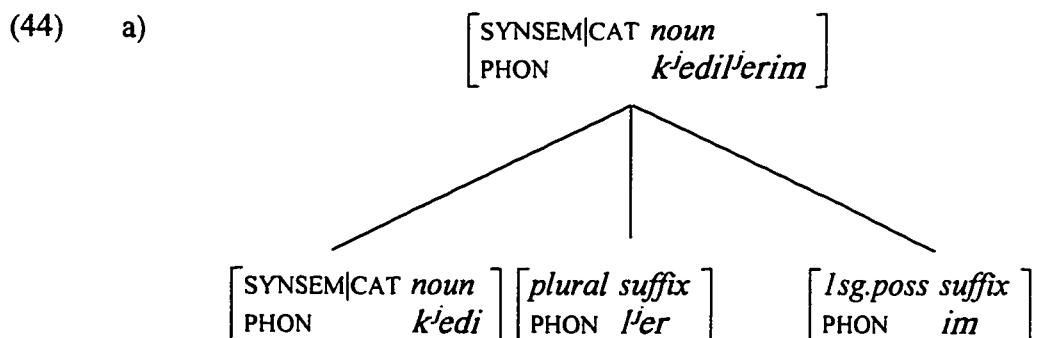

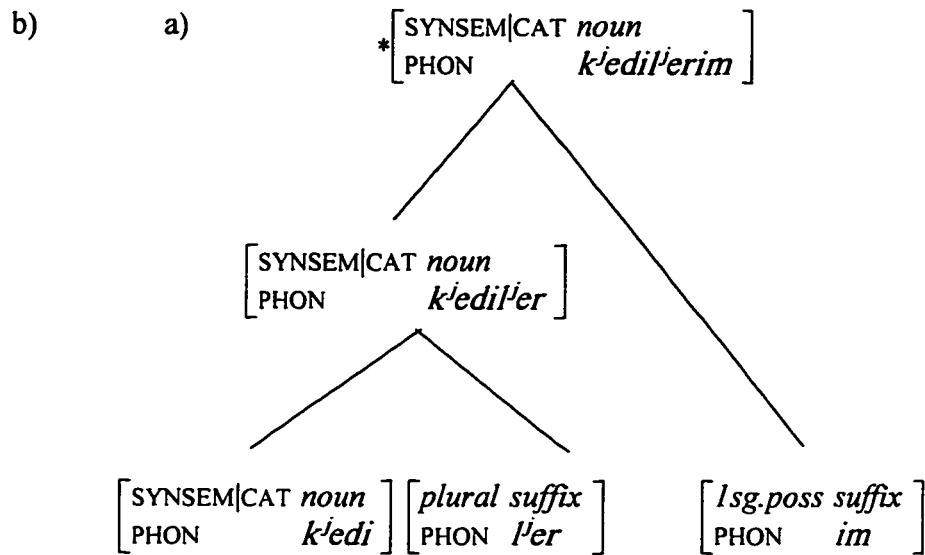

Given that the plural and possessive suffixes form a ternary branching structure with the base they attach to, the pattern of suspension in (45) is ungrammatical because it forces the plural and possessive suffixes to be in a hierarchical structure. This example is similar to the one we have seen before in (43b), except that the accusative suffix is not involved here. This further supports the position that the source of the problem is the configuration of the plural and possessive suffixes. There are two possible structures for this form. The first is shown in (45a). Here, the possessive suffix is attached to the conjoined noun phrase, as it has scope over both conjuncts. This configuration violates the condition that the plural and possessive suffixes must be sisters whenever they both have scope over the same head. Therefore, this structure is ruled out. This leaves us with the possibility in (45b), which is structurally well formed. However, this structure does not give us the desired scope relations. In particular, the possessive suffix has scope over the second conjunct but not the first conjunct. Therefore, we explain the fact that the plural and possessive suffixes have to be suspended together, or not suspended at all.

(45) * $[k^jedi-l^j'er\ ve\ k^j\o{p}ek^j-l^j'er]-im$
 [dog-pl and cat-pl]-1sg.poss

a) Problem: *-l^j'er* and *-im* not sisters

* $\left[\begin{array}{l} \text{SYNSEM} \left[\begin{array}{l} \text{CAT } \textit{noun} \\ \text{SEM 'my cats and dogs'} \end{array} \right] \\ \text{PHON } \textit{k^jedi-l^j'er\ ve\ k^j\o{p}ek^j-l^j'erim} \end{array} \right]$

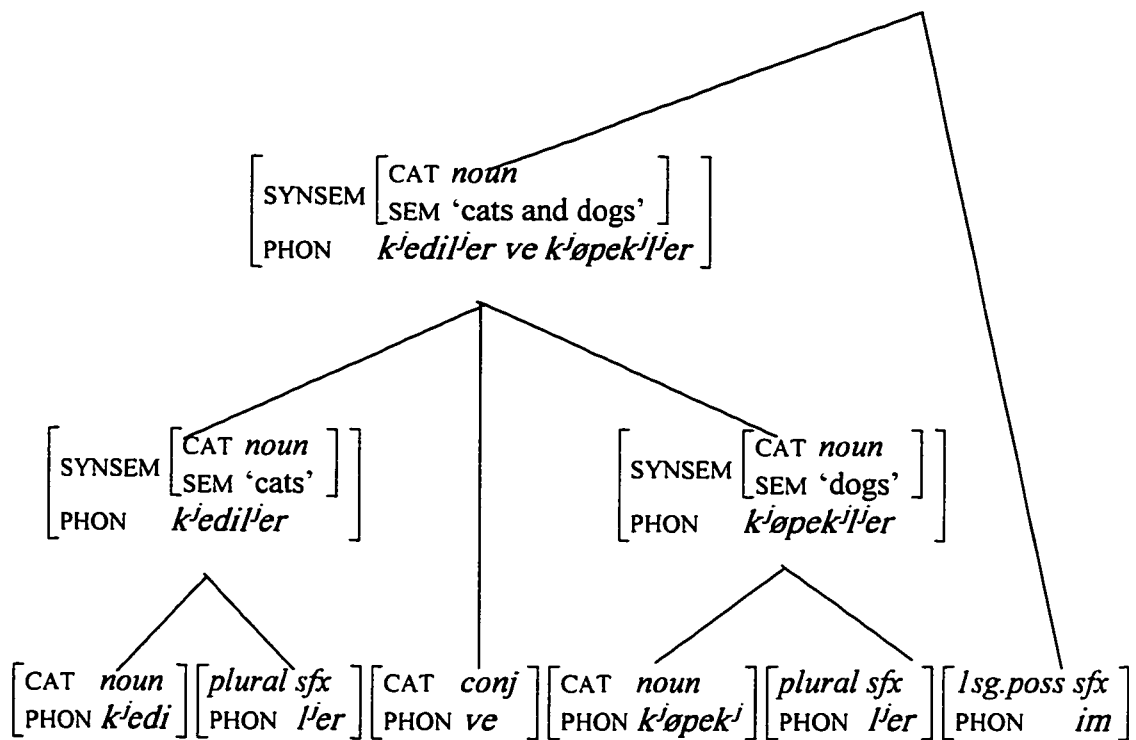

b) Problem: Incorrect scope (-*im*)¹⁹

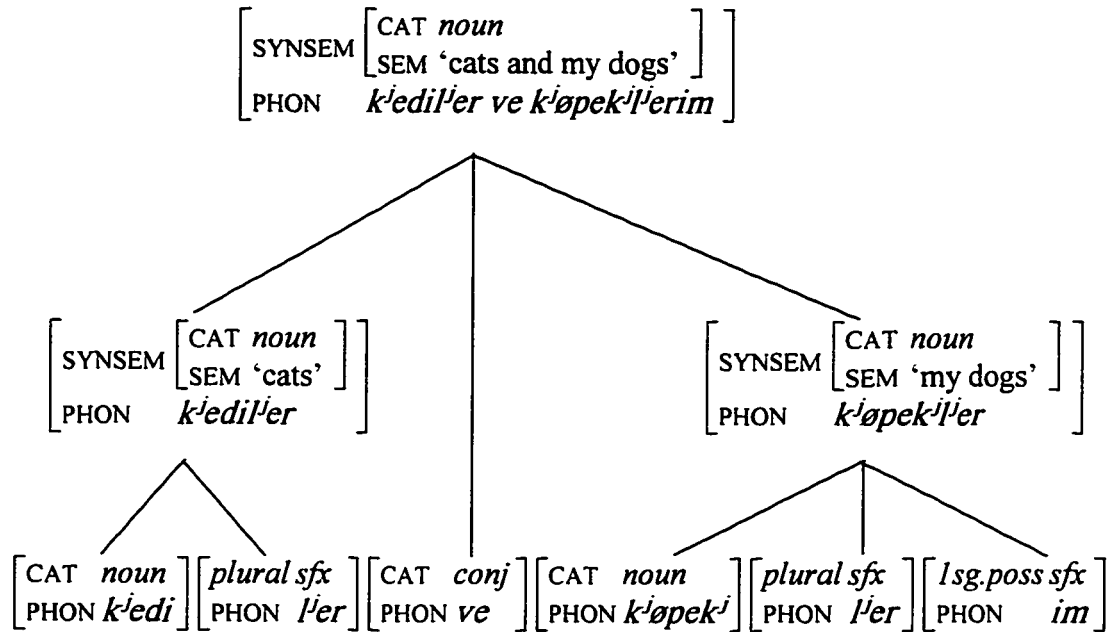

In general, then, suffixes can be separated in Suspended Affixation if and only if they form a hierarchical structure. If they form a flat structure, they have to be suspended as a group, or not at all.

Since the possessive and accusative suffixes can be suspended independently of one another (43a), they must form a binary branching, not a flat, structure. This is shown in (46):

¹⁹ This example is grammatical with the reading indicated on the top node. It is, however, not possible for the possessive suffix to have scope over both conjuncts.

(46)

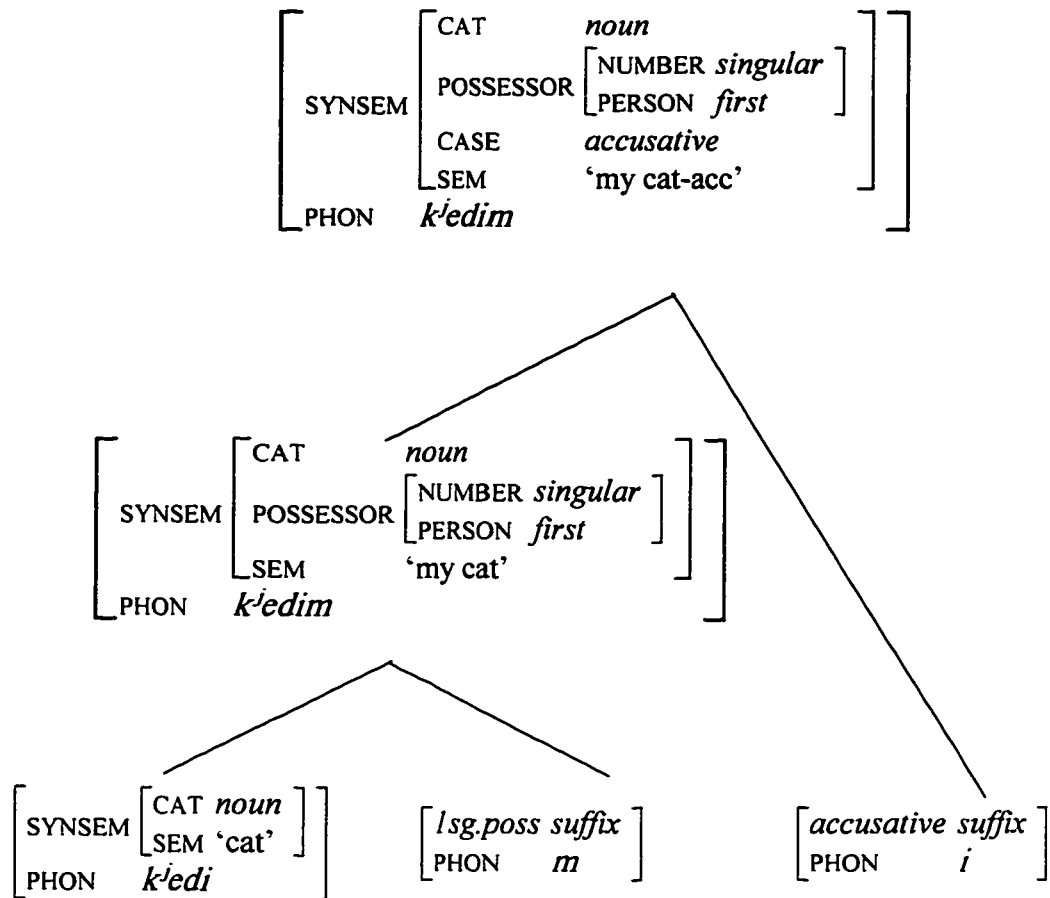

It turns out that certain suffixes can never be suspended. Passive and aspect suffixes belong to this group. Thus, the suspension patterns in (47) are all ungrammatical.

(47) a) al -un -ur ve ver -il^j -ir
take -pass -imprf and give -pass -imprf

*al ve ver -il^j -ir
*[al -un ve ver -il^j] -ir

b) al -ur ve ver -ir
take -imprf and give -imprf

*[al ve ver] -ir

As a result, there is no evidence from Suspended Affixation for flat or branching structures for passive and aspect suffixes. According to our methodological principle of assuming flat structures when there is no evidence for branching, the passive and aspect suffixes must form a flat structure, as in (39).

We have thus found striking confirmation for the structures assumed in section 2.1: when the minimal size condition seems to be enforced cyclically, indicating binary branching constituent structures, the suffixes in question can be suspended independently of each other, also indicating a binary branching structure.

(48) a) Possessive and case suffixes in Suspended Affixation: branching structure

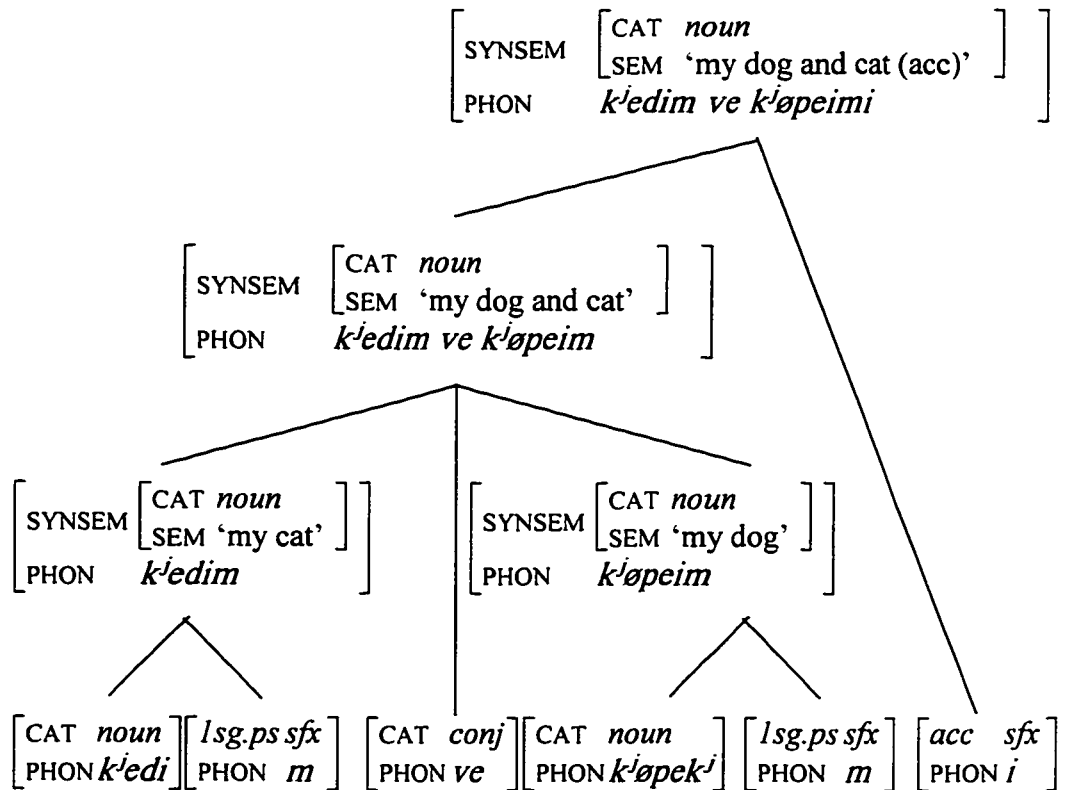

b) Minimality:branchingstructure

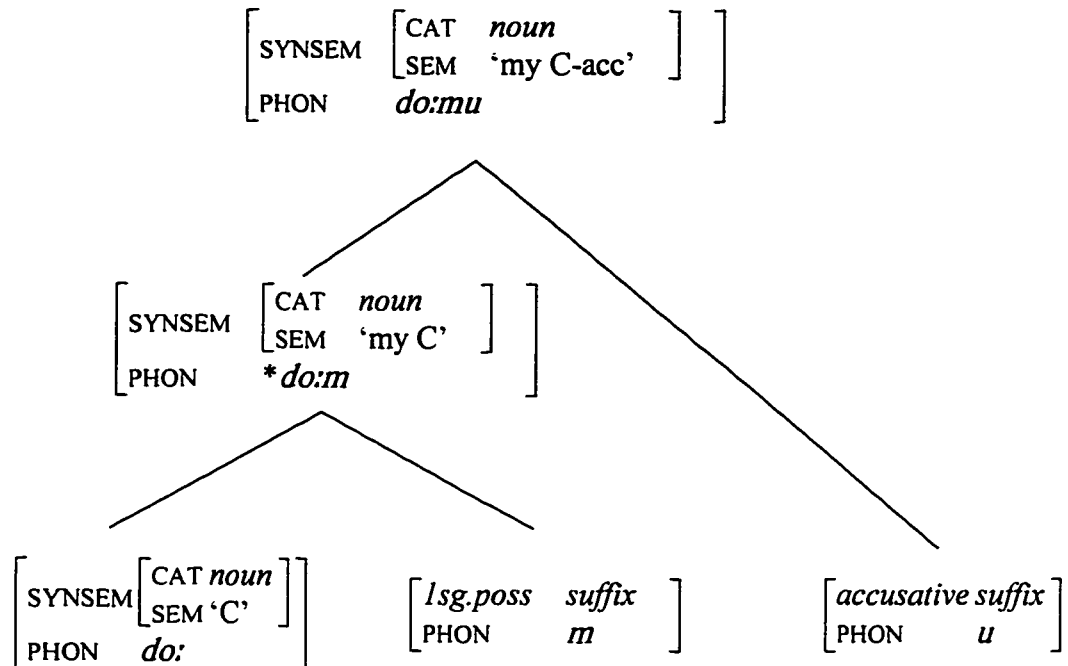

This convergence between purely phonologically motivated structures with morphologically motivated structures provides the most dramatic support for the framework of Sign-Based Morphology.

2.3 Optimality Theoretic analysis of Turkish minimality

In this section, I will present a rough Optimality Theoretic analysis of the Turkish data. The main challenge is to derive ungrammaticality. Since Optimality Theory is set up to declare the best candidate as the grammatical output, it would appear that there will always be a winner. Prince and Smolensky (1993) address this problem by proposing a “null parse” corresponding to a phonologically null output. If the null parse emerges as the winning candidate, no phonological output is created. By stipulation, the null parse satisfies every constraint except for a new one that Prince and Smolensky propose called

MPARSE, which the null parse alone violates. Ranking a constraint C above MPARSE amounts to declaring that C is inviolable: any candidate that violates C is worse than the null parse. If a number of constraints are ranked above C, and some of them conflict (that is, satisfying one entails violating another), then the null parse emerges as the winner. Ungrammaticality is then to be handled by ranking the responsible constraints above MPARSE.

The Turkish minimal size condition turns out to provide somewhat of a challenge to this approach. Orgun and Sprouse (1996a,b) have proposed a solution to this challenge, which I summarize here.

For the Turkish minimality case, the minimal size condition, which I will call $\sigma\sigma$, must therefore be ranked above MPARSE, such that, given input /je-n/ ‘eat-pass’, the null parse will be a better candidate than *jen. This is shown in (49):

(49)

/je-n/	$\sigma\sigma$	MPARSE
jen	*!	
∅		*

We must of course consider additional candidates, in particular, some that use phonological epenthesis to increase the size to the disyllabic minimum, such as *jene, *jein, *jejin, or *ijen. The candidates that have peripheral epenthesis could conceivably be ruled out by an inviolable constraint barring such epenthesis, which is never found in

Turkish in any case.²⁰ It turns out not to be a simple matter to rule out the other candidates, however. Epenthesis is possible elsewhere in Turkish, as in /sol^j-m/→[sol^jym]. This implies that the constraint against epenthesis (DEP in McCarthy and Prince 1995) is ranked lower than MPARSE. Otherwise the null parse would have been better than the epenthesizing candidate.

Vowel hiatus is also found, both within morphemes, and across morpheme boundaries (as a result of the productive intervocalic velar deletion process, as well as in a few morphophonemically irregular forms that fail to undergo glide epenthesis). Examples are given in (50), with syllable boundaries indicated by periods:

(50)	a.i.l ^j e	‘family’		
	re.is	‘chief’		
	ma.un	‘mahogany’		
	sokak	‘street’	sokα-a	‘street-dat’
	baluk	‘fish’	balu-u	‘fish-acc’
	mek ^j ik ^j	‘shuttle’	mek ^j i-im	‘shuttle-1sg.poss’
	musra:	‘line(poetry)’	musra:-u	‘line-acc’
	dʒa:mi	‘mosque’	dʒa:mi-i	‘mosque-3sg.poss’ ²¹

We must conclude that the constraint barring vowel hiatus (call it *V.V) is also ranked lower than MPARSE. The ranking we have so far is shown in (51):

²⁰ Except in some loanwords, such as *istim* ‘steam’. The account I am developing will fail even without this complication. Therefore, I will not dwell on the issue of loanword adaptation, which is the subject of considerable debate.

²¹ These are conservative forms that most speakers of Istanbul Turkish have regularized. It is thus more common today to find *musrasu* and *dʒa:misi* than *musra:u* and *dʒa:mii*.

(51) $\sigma\sigma \gg \text{MPARSE} \gg \text{DEP}, *VV$

This ranking, however, incorrectly predicts there to be a grammatical output for /je-n/ ‘eat-pass’. This is illustrated in (52):

(52)

/je-n/	$\sigma\sigma$	MPARSE	DEP, *VV
jen	*!		
(σ) \emptyset		*	
\bullet jein			**

Trying to rule out epenthesis next to a morpheme boundary would be futile, since this is the usual epenthesis site, and occurs even when the passive suffix *-n* itself is involved, as in *bul-un* ‘find-pass’.

Orgun and Sprouse propose to revise Prince and Smolensky’s approach to ungrammaticality as follows: instead of using MPARSE, they propose excluding all inviolable constraints from EVAL. EVAL then always selects a winner for any input. This winner is judged grammatical if it satisfies all the inviolable constraints, now grouped into a separate constraint component that Orgun and Sprouse call CONTROL. If the winner of EVAL violates a constraint in CONTROL, then it is ungrammatical. No grammatical output is possible in that case.

For the Turkish minimality problem, EVAL will contain usual phonological constraints such as syllable structure constraints, faithfulness to the input, and so on. CONTROL contains at least the disyllabic minimal size constraint. EVAL now selects *jen* as

the winning candidate for /je-n/ ‘eat-pass’, since this candidate is maximally faithful, and has no syllable structure or other problems (53):

(53)

/je-n/	DEP, *VV
☞ jen	
jein	**

This candidate, however, violates a constraint in CONTROL (54), as indicated by the scissors notation that Orgun and Sprouse have introduced:

(54)

	σσ
✂ jen	*!

Since the winner of EVAL violates a constraint in CONTROL, no grammatical output is possible, as desired. Further support for this approach to ungrammaticality is offered by Orgun and Sprouse on the basis of cross-linguistics evidence. A further example of ungrammaticality that calls for a CONTROL solution can be found in section 5.3 of this study.

2.4 Ondarroa Basque vowel height assimilation

Another phonological constraint that appears to be enforced cyclically or noncyclically depending on the morphological structure of the word in question is vowel height assimilation in Basque. The following discussion is based on Hualde (1989, 1991).

In the Ondarroa dialect of Basque, final low vowels become mid when there is a high vowel in the preceding syllable (a similar alternation takes place in most other

varieties of Basque as well, but the details are different; see Hualde 1991). Hualde characterizes this alternation as a rule that spreads [-low] to the final vowel. Descriptively, the rule in (55) indicates the environment for this alternation.

$$(55) \quad a \rightarrow e / \begin{matrix} V \\ [+hi] \end{matrix} C_0 \text{ ___} \#$$

An example of the alternation is given in (56). In (56a), the definite article clitic *-a* is attached to a stem whose last vowel is mid. Raising does not apply. In (56b), the same clitic is attached to a word whose last vowel is high. The clitic vowel raises to [e] in this case.

- (56) a) /giʃon-a/ [giʃona] ‘the man’
 b) /lagun-a/ [layune] ‘the friend’

The data in (57) show that this is a “derived environment rule,” that is, it only applies across morpheme boundaries. Thus, the low vowels in (57) do not raise to mid, yielding *fabrike, *tʃimiste.

- (57) fabrika ‘factory’
 tʃimista ‘lightning’

The data in (58) show that suffixes (as well as the definite article clitic in (56)) undergo raising. In (58a), the suffixes *-ka* and *-na* are added to stems whose last vowel is low. Raising does not apply. In (58b), the same suffixes are added to stems that end in high

vowels, and raise to *-ke* and *-je* (the palatalization of the [n] is due to the preceding [i]; this is an independent alternation that we are not concerned with).

(58) Suffixes that undergo raising

- | | | | |
|----|-------------|------------|-------------------|
| a) | /pelota-ka/ | [pelotaka] | ‘throwing a ball’ |
| | /bat-na/ | [bana] | ‘one for each’ |
| b) | /ari-ka/ | [arike] | ‘throwing stones’ |
| | /bi-na/ | [biŋe] | ‘two for each’ |

More examples of clitics that undergo raising are given in (59). Once again, the forms in (59) do not exhibit raising, since the clitics in these forms do not follow high vowels, while the forms in (59b) do, since the clitics here follow high vowels.

(59) Clitics that undergo raising

- | | | | |
|----|-----------------|---------------|------------------|
| a) | /koldo ta peru/ | [koldotaperu] | ‘Koldo and Peru’ |
| | /amen da/ | [amenda] | ‘here it is’ |
| b) | /peru ta koldo/ | [perutekoldo] | ‘Peru and Koldo’ |
| | /xun da/ | [xunde] | ‘he has gone’ |

The data in (60) show that raising does not apply to vowels that are not final. The forms in (60a) end in a consonant, and do not undergo raising. The forms in (60b) are phonologically similar except that they end in a vowel; these forms do undergo raising.

- | | | | |
|------|----|----------|-----------------|
| (60) | a) | ur-ak | ‘water-abs.pl’ |
| | | layun-ak | ‘friend-abs.pl’ |

b)	ur-e	‘water-abs.sg’
	layun-e	‘friend-abs.pl’

The data in (61) confirm that the forms in (60b) indeed exhibit raising, as opposed to simply being underlyingly mid. In (61), the absolute singular suffix is added to stems whose last vowel is not high. The suffix in these cases surfaces with a low vowel rather than a mid one.

(61)	giʃon-a	‘man-abs.sg’
	ar-a	‘worm-abs.sg’

In summary, raising applies across morpheme boundaries to word final vowels when preceded by a high vowel.

2.5 Optimality Theoretic analysis of Basque vowel height assimilation

In this section, I will present a very simple analysis of Basque vowel height assimilation. This is just for illustrative purposes. Of the various approaches to assimilation in the Optimality Theory literature, any one may be chosen, and will be consistent with Sign-Based Morphology.

I start by assuming that two vowel height features, [high] and [low] are active in Ondarroa Basque. High vowels are [+high, -low], mid vowels, [-high, -low], and low vowels, [-high, +low]. Vowel height assimilation causes an input low vowel to correspond to an output mid vowel following an output high vowel (across any number of consonants). I formulate the constraint responsible for this alternation as a negative target

constraint along the lines of McCarthy 1996. McCarthy's constraint format allows specification of underlying or surface levels for the trigger or target. Surface specification is considered the unmarked case. For the Basque problem, it is possible to use all surface specifications. The constraint is shown in (62):

(62)		Condition	Level
	α	[+high]	Surface
	β	[+low]	Surface
	Precedence	<	Surface
	Adjacency	V to V	Surface

The constraint, which I will call $*[+high]C_0[+low]$ rules out a high vowel followed by a low vowel. Other constraints must be called on to make sure that potential violations of this constraint are avoided by raising the second vowel rather than any other means (for example, lowering the first vowel, deleting one of the vowels, or inserting a mid vowel between them). The constraints involved are various faithfulness constraints. The constraint IDENT(+high) makes sure that the first vowel will not be lowered. The constraints MAX-V and DEP-V make sure that a vowel will not be deleted or inserted. All these constraints are ranked above IDENT(+low), requiring faithfulness to an underlying [+low] specification. The following tableau illustrates how the system works:²²

²² The restriction of the alternation to word final vowels is not handled by this formulation. One way to fix this deficiency would be to build this restriction into the constraint by changing the constraint to something like $[+hi]C_0[+lo]\#$, where # indicates the end of the phonological domain. This new constraint does not fit into McCarthy's format. Another way to deal with the problem would be to look for a special "morpheme integrity" type constraint that requires faithfulness to nonperipheral segments. This might be a better motivated move in light of the crosslinguistically special status of peripheral segments.

(63)

/bi-na/	*[+hi]C ₀ [+lo]	IDENT(+hi)	MAX-V	DEP-V	IDENT(+lo)
bina	*!				
bená		*!			
biena				*!	
bijn			*!		
☞ bigne					*

This analysis, however, incorrectly predicts that there should be no morpheme internal high vowel-low vowel sequences, as in *tfimista* ‘lightning’. In fact, vowel height assimilation applies only across morpheme boundaries in Ondarroa Basque. There are two ways of dealing with this difficulty. The first is stipulating, in the fashion of the Strict Cycle Condition, that the constraint *[+hi]C₀[+lo] only applies when there is a morpheme boundary somewhere in its environment. The second way is to try to derive this effect instead of stipulating it, as Kiparsky (1993) has proposed, from underspecification. This involves assuming that the suffix vowels that undergo this alternation are underspecified for + or -low, and that IDENT(+low) is ranked higher than *[+hi]C₀[+lo]. If we assume in addition that + is the default value for low (that is, *[-low] » *[+low]), we obtain the desired result. With this new ranking, and the new underspecified representation for affix vowels, vowel height assimilation follows as shown in the tableau in (64):

(64)

/bi-na/	IDENT(+lo)	*[+hi]C ₀ [+lo]	IDENT(+hi)	MAX-V	DEP-V
bina		*!			
bená			*!		
biena					*!
bijn				*!	
☞ bigne					

The root *tʃimista* ‘lightning’, on the other hand, has a fully specified vowel. In this case, the optimal candidate is the faithful one, as shown in (65):

(65)

/tʃimista/	IDENT(+lo)	*[+hi]C ₀ [+lo]	IDENT(+hi)	MAX-V	DEP-V
☞ tʃimista					
tʃimiste	*!				

Kiparsky’s proposal depends crucially on his assumption of Radical Underspecification. The current trend in Optimality Theory, however, is to leave underlying representations unrestricted, and to require that the grammar choose a legitimate output for any input. We must therefore consider different possible inputs with underspecified and fully specified vowels. Assuming an underspecified vowel within a root will give rise to an [iC₀e] sequence, which is legitimate. Assuming a fully specified vowel in an affix would predict that that affix will fail to undergo vowel height assimilation, surfacing consistently with a low vowel regardless of the environment it is in. Hualde (1991) does not report any such consistently low affix vowels in Ondarroa Basque. Such vowels are, however, found in other dialects of Basque, which also have a similar vowel height assimilation process. For example, in Baztan Basque, the suffixes *-garen* ‘ordinal’, *-tar* ‘origin’, and *-ago* ‘more’ idiosyncratically fail to undergo vowel height assimilation (in this dialect, vowel height assimilation is not restricted to word final vowels as it is in Ondarroa, as shown by examples like *tratu-leri* ‘dealer’ versus *eske-lari* ‘beggar’). It might therefore be considered an accidental gap in Ondarroa Basque that such nonalternating suffixes are not

found. The restriction that the target vowel be word final causes the set of eligible suffixes small to begin with in any case.

Whether we choose to stipulate the restriction of vowel height assimilation to morphologically derived environments or relate it to underspecification, an Optimality Theoretic account is readily formulable, and meshes nicely with Sign-Based Morphology.

2.6 Cyclic and noncyclic effects in Basque vowel height assimilation

What happens when multiple affixes or clitics are added to a form, resulting in a number of stem-final vowels, one for each morphological subconstituent? The data in (66) show that raising does not apply cyclically in this case, as Hualde also notes. That is, raising does not apply to the final vowels of intermediate morphological constituents. It only applies to vowels in the absolute word-final position. In (66a), the suffix vowel is word final and undergoes raising. In (66b), the suffix vowel is stem final (as in [[bi-na] ka]), yet does not undergo raising.

(66) Noncyclic application in multiply suffixed forms

a)	/mutil-a/	[muti ^h e]	‘the boy’
	/bi-na/	[bi ^h ne]	‘two for each’
	/ari-ka/	[arike]	‘throwing stones’
b)	/bi-na-ka/	[bi ^h naka]	‘two by two’
	/mutil-a-k/	[muti ^h ak]	‘the boy-erg’
	/ari-ka-da/	[arikara]	‘throwing of a stone’

Since noncyclic application follows from flat structures, the forms with three morphemes in (66) must all have ternary branching constituent structures. The structure for *muti λ e* ‘the boy’ is shown in (67):

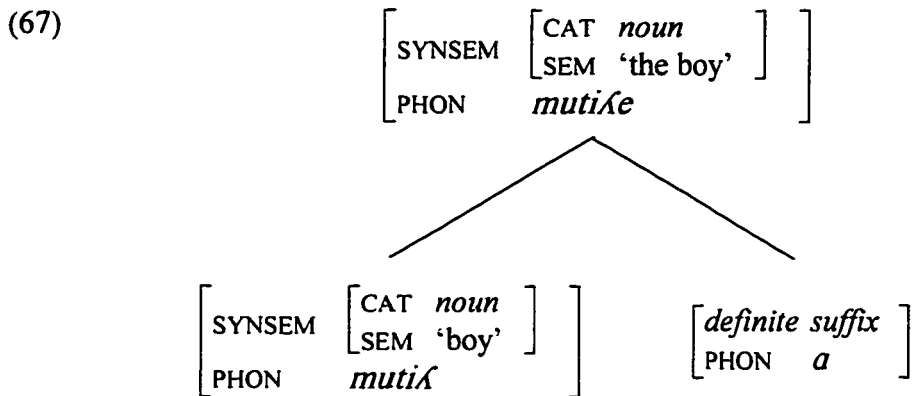

In this form, the environment for vowel height assimilation is met in the mother node. Thus, the underlying /a/ of the definite article corresponds to an /e/ in the mother node. Compare this with the constituent structure for the form *muti λ ak* ‘the boy-erg’ in (68):

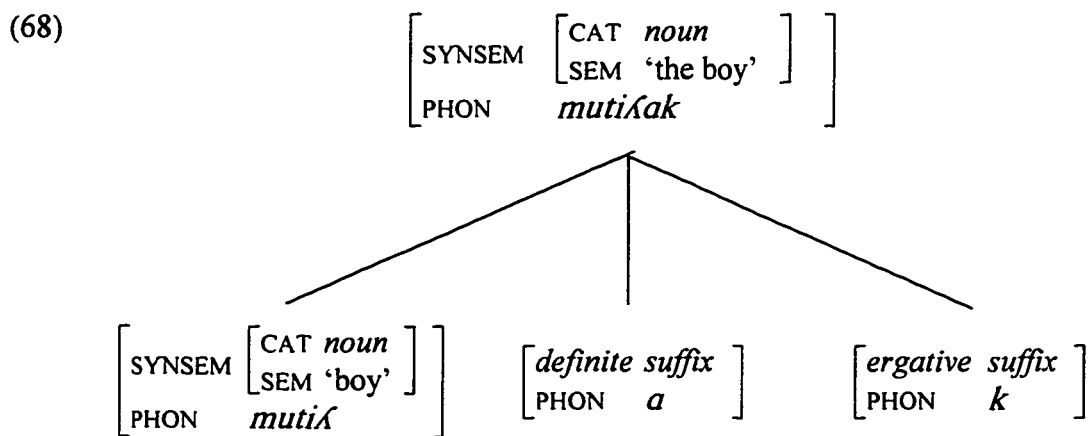

In this form, the environment for vowel height assimilation is not met, as the definite article's /a/ is not final in the mother node. Assimilation therefore does not apply. There is no possibility of cyclic phonological effects in flat structures.

We have seen that the apparent noncyclic application of vowel height assimilation can be handled by positing a flat structure for the forms involved. However, as Hualde shows, in forms containing clitics, raising applies to the base that the clitic attaches to, as well as to the whole word including the clitic. In (69a), the vowel of the definite article raises to [e] even though it is not word-final. The stem that the clitic attaches to qualifies as a domain for raising. In (69b), we see that the clitic vowel is itself subject to raising when preceded by a high vowel. This suggests cyclic application, with raising applying both “before” and “after” cliticization.

(69) Cyclic application in forms containing clitics

a) Applies before clitics:

/lagun-a-da/ [layunera] ‘it is the friend’
/mendi-a-da/ [mendiɟera] ‘it is the mountain’

b) Applies to clitics:

/buru-a-da/ [burure] ‘it is the head’
/baso-a-da/ [basure] ‘it is the forest’

Raising in Ondarroa Basque is similar to the minimal size condition in Istanbul Turkish in that both may apply cyclically or noncyclically depending on morphological factors. The solution is also similar. Since cyclic application follows from branching structure, the

forms in (69) must have binary branching structures. The structure for *layunera* ‘it is the friend’ is shown in (70):

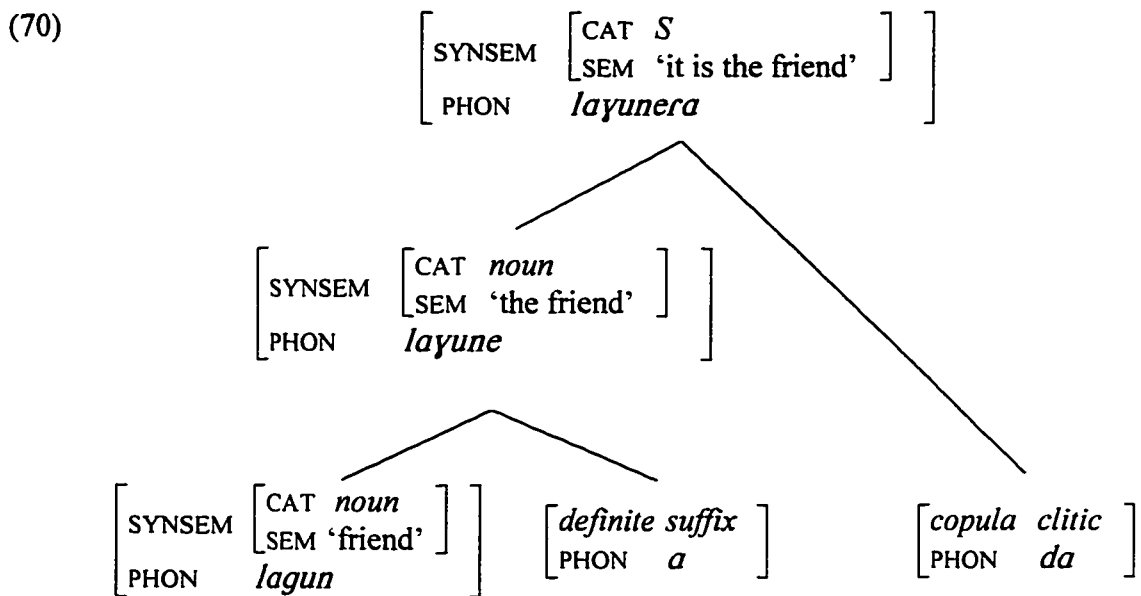

In this form, the environment for vowel height assimilation is met in the intermediate node *layune* ‘the friend’. The final vowel of this constituent is therefore /e/. Thus, the branching structure we assume accounts for the apparent cyclic application of vowel height assimilation in these forms.

We have seen that cyclic as well as noncyclic phonological effects follow from static constituent structure configurations in Sign-Based Morphology. In the Turkish case, the branching and flat structures needed for prosodic minimality enforcement match those motivated by Suspended Affixation. This match between phonologically and morphologically motivated structures provides striking support for the theory.

So far, I have introduced the basic structure of Sign-Based Morphology, and shown how it can offer a principled account of the apparent cyclic versus noncyclic application of phonology. In the next chapter (chapter 3), I discuss the relationship between Sign-Based Morphology and other theories of morphology.

Chapter 3. Connections to other theories

In this chapter, I present a more formal and complete introduction to the structure of Sign-Based Morphology and discuss the similarities and differences between Sign-Based Morphology and other approaches to morphology. Sign-Based Morphology owes major insights to a number of past and present approaches to morphology, including ones that are often thought to be mutually incompatible. In this chapter, I show how Sign-Based Morphology utilizes the major insights of a number of different theories, while avoiding their problems.

3.1 Why Sign-Based Morphology is different

In this section I introduce the basic structure of Sign-Based Morphology. Although Sign-Based Morphology owes much to a number of different approaches to morphology and phonology, including Lexical Phonology (Kiparsky 1982, Mohanan 1982), Prosodic Lexical Phonology (Inkelas 1988), A-Morphous Morphology (Anderson 1992) and related approaches (e.g., Janda 1983, Zwicky 1994, Stump 1995), and various approaches to morphology within the unification-based linguistic tradition (e.g., Ackerman and LeSourd 1993, Riehemann 1993, 1994, Koenig 1994), I will use as my starting point in this section Lieber's (1980) dissertation as a well-worked out example of a constituent-structure-based understanding of morphology. It should be noted that the development here does not depend crucially on the details of Lieber's theory and is consistent with any constituent structure approach, including, for example, that of Selkirk 1982.

I begin with a brief discussion of the difference between “sign-based” and “terminal-based” approaches to linguistics (these terms were first introduced in Orgun 1995a). This is a critical contrast to draw, as past criticisms of interleaving (that is, cyclicity or level ordering) as “extraneous” crucially, if implicitly, assume a terminal-based approach to grammar, and are not valid if a sign-based conception is adopted instead. After introducing this important distinction, I demonstrate that there are no truly terminal-based approaches to linguistics. Finally, I show that interleaving effects can be viewed as a direct consequence of using sign-based constituent structures.

In the terminal-based approach, which underlies work in the Structuralist item and arrangement tradition, terminal nodes are the only information-bearing elements in a constituent structure. The sole role of nonterminal nodes is to organize the terminal nodes into groups. The meaning of a linguistic form is assembled from the semantic information in the terminal nodes, while the phonology is determined by some phonological system operating on the strings supplied by the terminal nodes, which are the underlying representations of the morphemes that occupy those nodes. The status of phonology in this kind of model is illustrated in (71) for the Mandarin form *máwéizǎo* ‘kelp’.

(71) “Terminal-based” approach

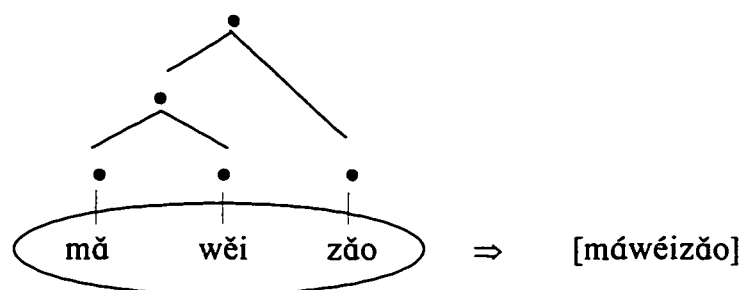

Sign-based theories of linguistics differ from terminal-based ones in assuming that every node in a constituent structure, whether terminal or nonterminal, is an information-bearing element. That is, *all* nodes carry syntactic, semantic, and phonological information. The following discussion of sign-based linguistics highlights what is important for the purposes of this study (for a more detailed general introduction, see Shieber 1986 and Pollard and Sag 1987, Pollard and Sag 1994).

A “sign” is defined as a Saussurean pairing between some phonological shape and some semantic information. In sign-based theories, a constituent structure is a statement of how the grammar justifies (licenses) the form-meaning pairing represented by the top node. Example (72) shows a sign-based representation of the same Mandarin form *máwéizǎo* ‘it is the friend’ whose terminal-based representation was given in (71). The syntactic and semantic features are highly abbreviated for the sake of conciseness.

(72) “Sign-based” approach

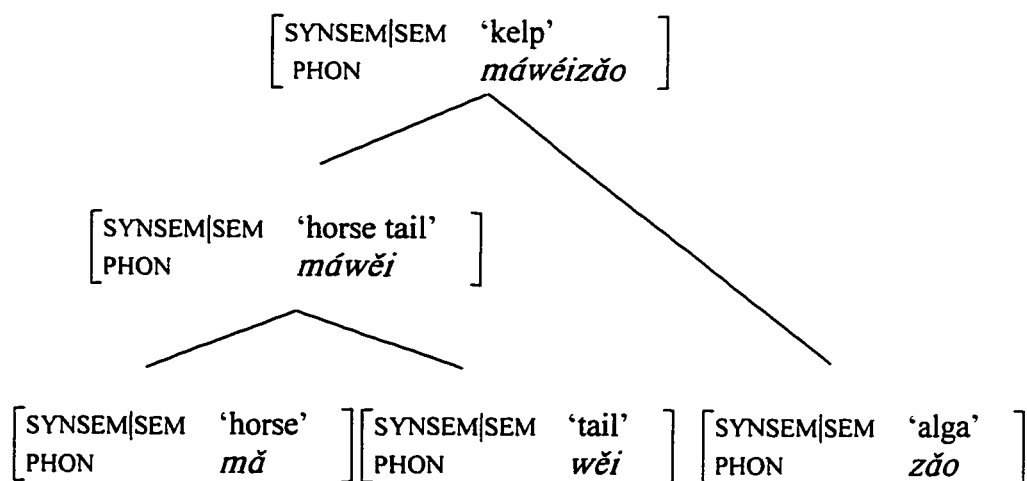

Constituent structures have a dual interpretation. They can be seen as representing:

- i) the internal part-whole structure of a sign (the syntagmatic interpretation): a constituent structure is a statement of how the grammar licenses the sign comprising the string of linguistic units (terminal nodes) in question. In this interpretation, a sign is understood not as just a simple Saussurean form-meaning pair, but rather as a more complex representation that has an internal constituent structure which itself contains (smaller) signs.
- ii) a statement of what in the lexicon and grammar makes it possible for the sign represented by the top node to exist and how it is related to other signs of the language (the paradigmatic interpretation). In this interpretation, a sign is seen strictly as a Saussurean form-meaning pair. Each node in a constituent structure is thus a sign.

The sign *máwéizǎo* ‘kelp’ is licensed in Mandarin for the following reasons:

- i) the signs *máwěi* ‘horse tail’ and *zǎo* ‘algae’ exist
- ii) there is a statement in the grammar, that is, a construction, stating that the existence of two nominal signs permits the existence of a third nominal sign (*máwéizǎo*) which combines the phonological and semantic information from these two signs in a particular fashion.

The sign *máwěi* ‘horse tail’ itself is licensed in a similar manner; the signs *mǎ* ‘horse’ and *wěi* ‘tail’ exist in the lexicon, and *máwěi* is the result of combining them in the appropriate way.

Most work in linguistics appears to assume a terminal-based approach; theories which are explicitly sign-based are a distinct minority. However, this contrast is in fact illusory. I am aware of no linguistic theory since Structuralism which attributes no information to nonterminal nodes. All current constituent-based approaches to linguistics use some kind of feature percolation, thereby locating at least some information on the nonterminal nodes. The fact that nonterminal nodes bear category features is enough to illustrate this point. For example, in the constituent structure in (73), the category label of the mother node is the same as the category label of the head daughter, an instance of head feature percolation.

(73)

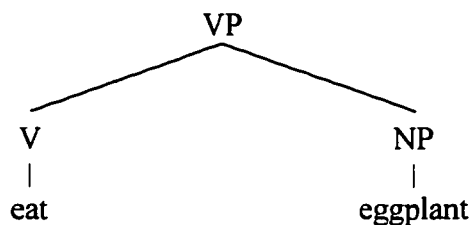

The need for assigning featural information to nonterminal nodes in a constituent structure was recognized even within the Structuralist tradition by Hockett 1954, who observed that a pure item-and-arrangement view (a pure terminal-based approach in the terminology I use here) is therefore untenable.

The following quote from Pinker 1994 makes even clearer the necessity of feature percolation:

(74) “Take the English noun phrase. A noun phrase (NP) is named after one special word, a noun, that must be inside it. The noun phrase owes most of its properties to that one noun. For example, the NP *the cat in the hat* refers to a kind of cat, not a kind of hat; the meaning of the word *cat* is the core of the meaning of the whole

phrase. Similarly, the phrase *fox in socks* refers to a fox, not socks, and the entire phrase is singular in number (that is, we say that the fox in socks *is* or *was here*, not *are* or *were here*), because the word *fox* is singular in number. This special noun is called the “head” of the phrase, and the information filed with that word in memory “percolates up” to the topmost node, where it is interpreted as characterizing the whole phrase as a whole.” (Pinker 1994:106-7) [*italics added*]

Although this quotation describes only head feature percolation, some of the features of a nonterminal node will of course depend on non-head daughters as well (e.g., the contrast in definiteness between *the fox* and *a fox*).

To sum up, Sign-Based Morphology differs from most approaches to morphology in its thorough use of feature percolation. All nodes are assumed to contain syntactic, semantic, and phonological information. As we have already seen in chapter 2, this architecture derives phonology-morphology interleaving effects in a declarative fashion. It has the further advantage of deriving noncyclic phonological effects as well.

3.2 Why Sign-Based Morphology is not different

In this section, I will discuss the insights that Sign-Based Morphology shares with other approaches to morphology.

3.2.1 From Lieber 1980 to Sign-Based Morphology: the item-and-arrangement connection

I have argued in section 3.2 that all constituent structure-based approaches to linguistics can be considered sign-based, because all allow some degree of feature percolation. In all theories, nonterminal nodes bear at least category features. A particularly well worked out theory of feature percolation in morphological structures has been proposed by Lieber

1980. My claim in this section is that Lieber's theory can quite justly be considered sign-based. By starting with Lieber's approach to morphology, and making one minor change that makes the theory internally more consistent, we arrive at Sign-Based Morphology.

Consider the following constituent structure from Lieber 1980:90) for the Latin verb form *diksera:mus* 'say.past-perf-1pl' (where "0" means the value of the feature in question is not specified).²³

²³ The nonbranching dominance of the root *diks* by a preterminal node is an interesting issue that has to do with the status of "root cycle" effects (that is, bare roots being subject to phonology on their own; see, for example, Kiparsky 1982 and Mohanan 1982, 1986). I abstract away from this issue pending further investigation within Sign-Based Morphology.

(75)

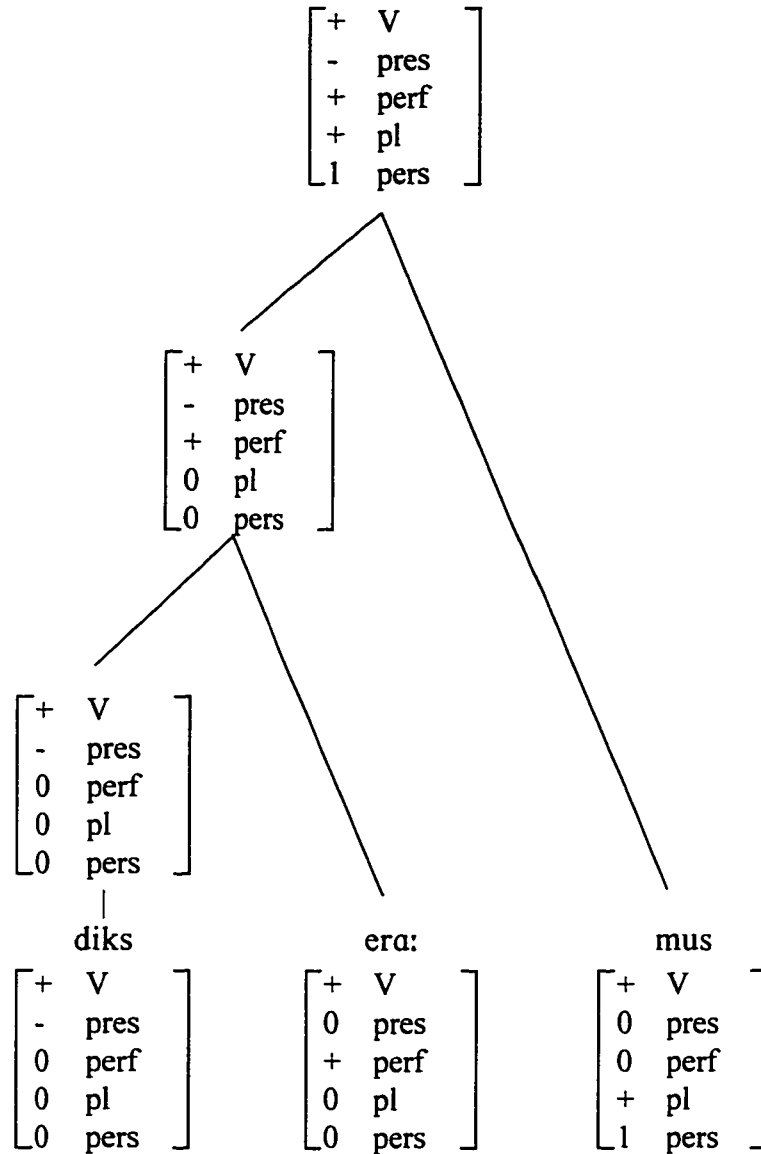

The morphosyntactic and semantic features of each nonterminal node are determined by a number of “feature percolation conventions” in Lieber’s approach. In any approach using constituent structures, the feature composition of a nonterminal node will be related to the features of its immediate constituents through some constraints. By notating this dependency as a function, and using SYNSEM and PHON for the syntactic, semantic, and

phonological features of a given node, we arrive at the following representation of the Latin verb form:

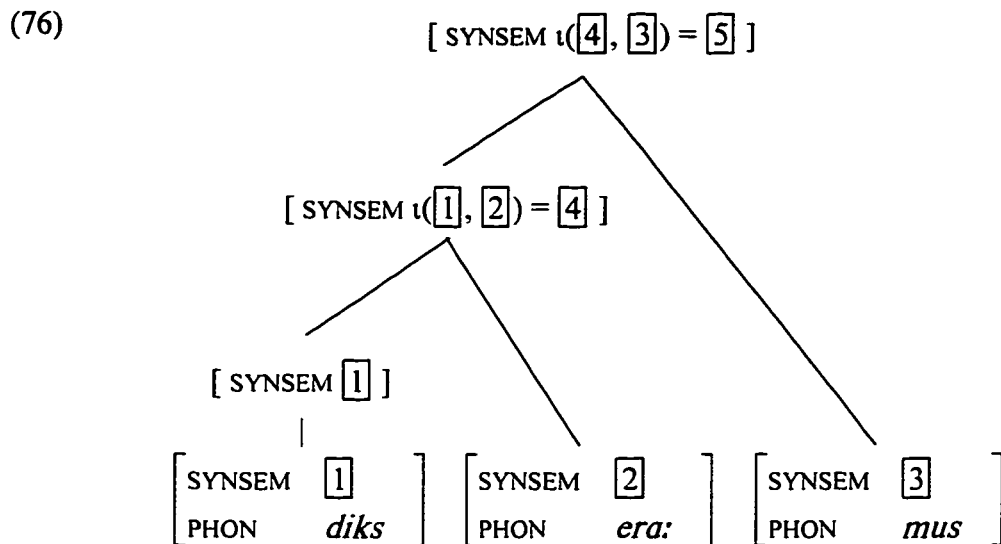

At this point, it is clear that the only terminal-based aspect of Lieber's approach is its treatment of phonology. Nonterminal nodes in Lieber's constituent structures do bear syntactic and semantic information. The decision to single out phonology as the only type of information borne exclusively by terminal nodes is arbitrary.²⁴

An internally more consistent approach would treat phonological information on a par with syntactic and semantic information. In such an approach, nonterminal nodes would carry phonological as well as syntactic and semantic information. The phonological information of a nonterminal node would be subject to constraints relating it to the phonology of the immediate constituents. The resulting representation of the Latin verb form is shown in (77).

(77)

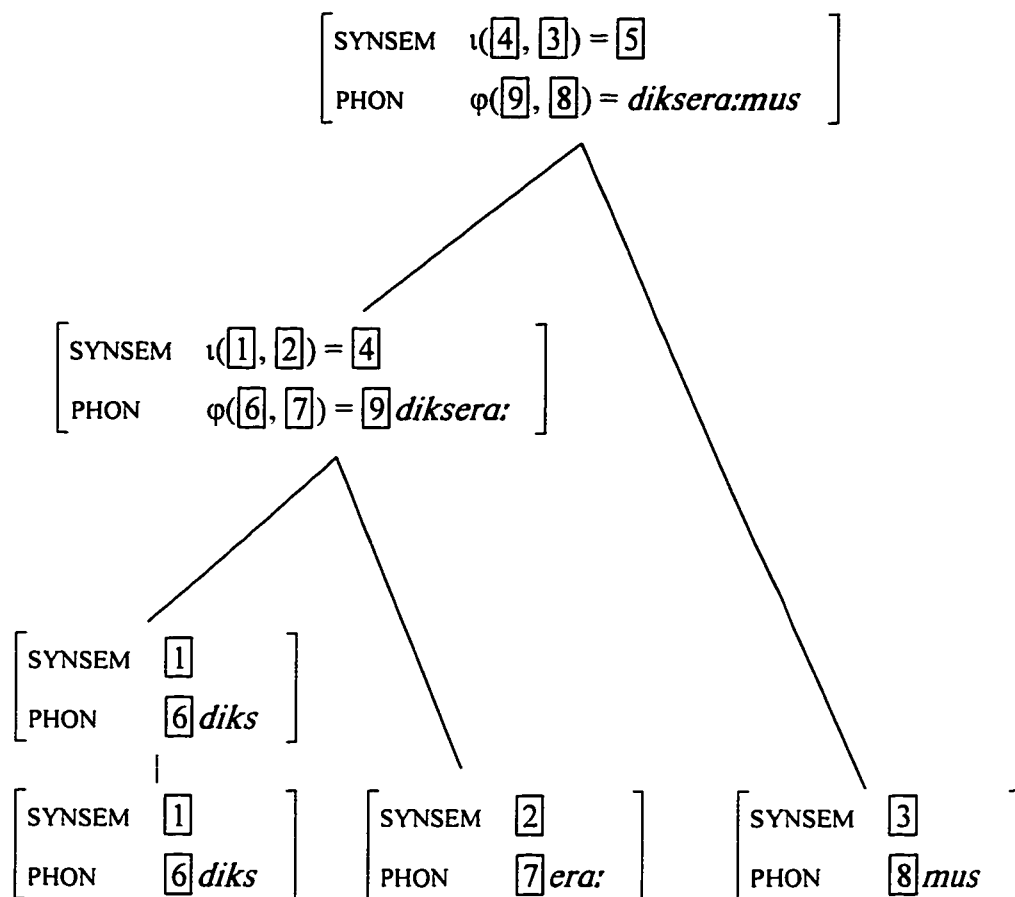

This is of course identical to a sign-based representation.²⁵ At this point, it should be clear that even approaches stated in terminal-based terms in fact possess all the tools necessary to achieve a nonderivational account of interleaving effects. Criticisms of interleaving as “derivational” or “formally extraneous” (for example, Cole 1990, Goldsmith 1993, Karttunen 1993, Kennedy 1994, Benua 1995, Kenstowicz 1995, Benua 1996 are aimed at the specific model assumed in Lexical Phonology, which was indeed derivational.

24 This arbitrary decision costs Lieber’s approach dearly: she is forced to assign nonconcatenative morphology to a separate “transformational” module, as terminal-based constituent structures are unable to deal with such phenomena.

However, the discussion above makes it clear that a declarative, constituent structure based theory of linguistics possesses all the tools to develop a declarative theory of cyclic phonological effects. Sign-Based Morphology thus does away with the fear that any direct account of cyclic phonological effects must be derivational.

I will end this section with a brief demonstration of how the sign-based architecture derives the apparent cyclic application of Mandarin third tone sandhi in a nonderivational manner. A sign based representation of the form *rǔanzǐcǎo* 'Arnebia Euchroma' is given in (78):

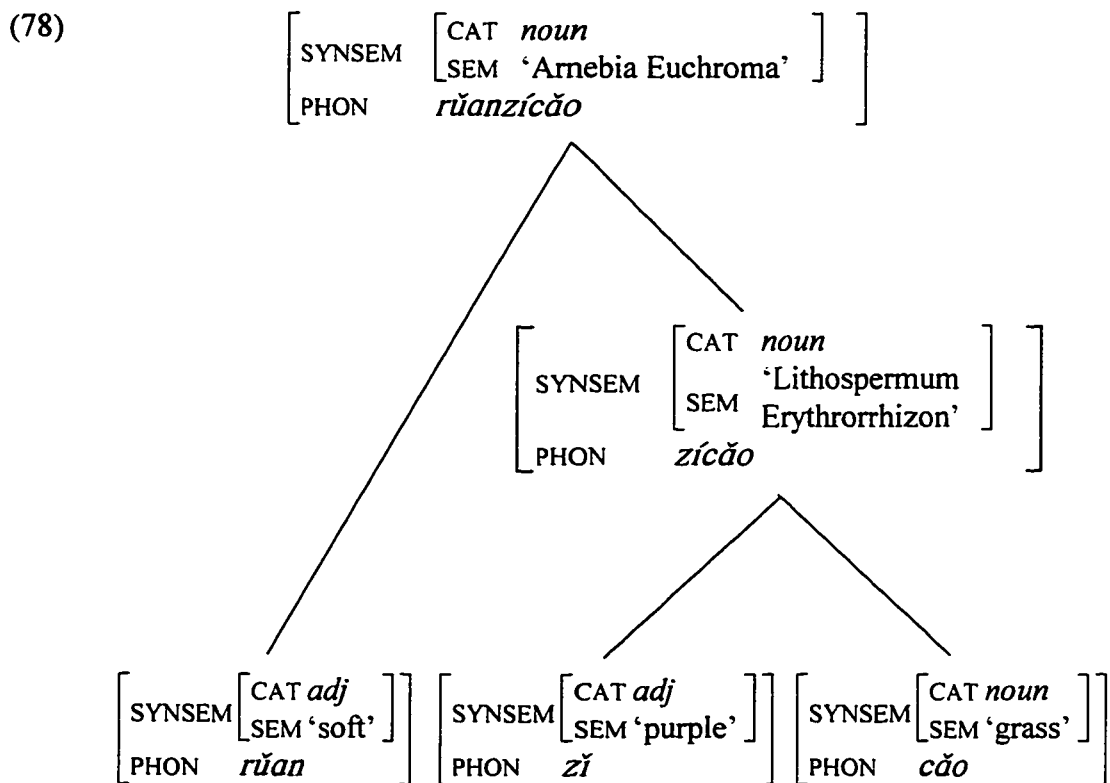

25 Bird (1990) presents the same kind of structure in his introduction to unification-based grammar formalisms. However, he does not recognize the implications of this for interleaving.

The phonology of the top node in this structure is determined on the basis of the phonologies of its immediate constituents, and *rǔan* and *zǐcǎo*. Since the environment of tone sandhi is not present in the juncture between these two forms, sandhi does not apply. The structure for the form *máwéizǎo* ‘kelp’ is shown in (79):

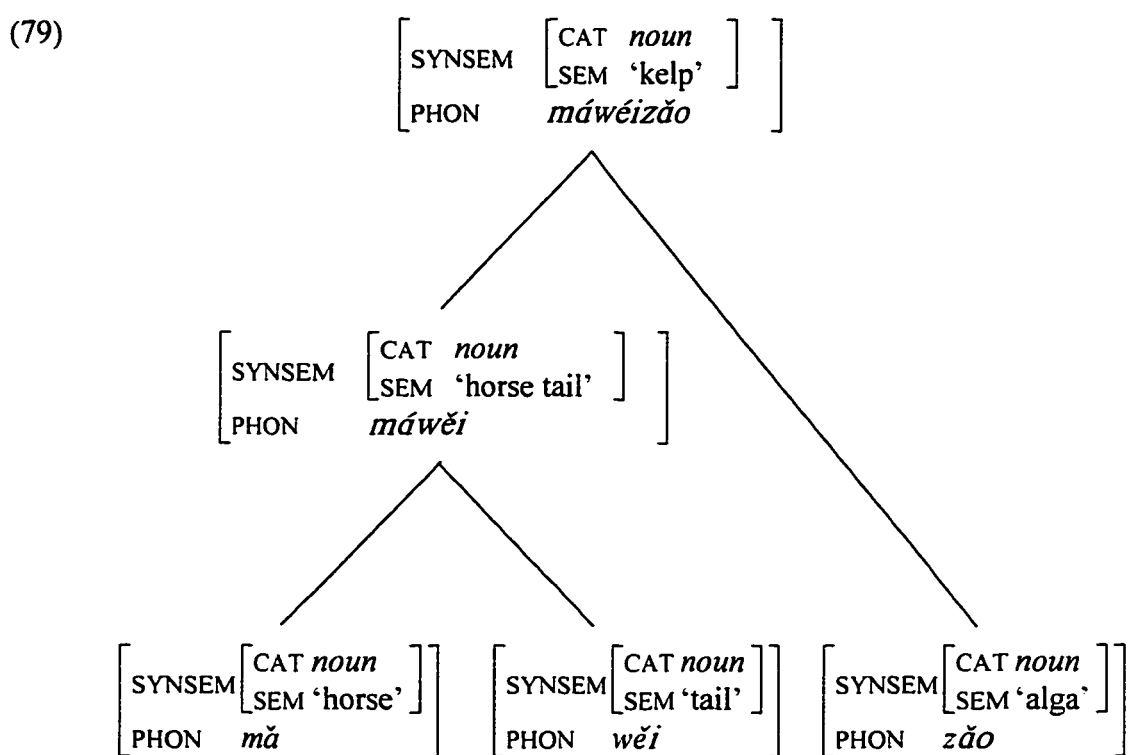

In this form, the phonology of the top node is similarly determined on the basis of the phonologies of its immediate constituents. This time, the environment of sandhi is met at the juncture between these daughter nodes. Therefore, the top node has a second, rather than a third, tone corresponding to the final third tone of the left daughter.

We have seen how cyclic phonological effects follow as an automatic consequence of local tree wellformedness. The phonology of each node depends on the phonologies of its immediate constituents, deriving interleaving (that is, cyclicity or Level Ordering) effects from static phrase structure configurations. Objections to cyclicity on the grounds that it is necessarily derivational are based on a terminal-based understanding of phrase structures. In such a model, the only way to generate cyclic phonological effects is to apply phonology first to the most deeply embedded constituents, and then successively to larger constituents. This is clearly a derivational model. However, I have demonstrated that:

- i) in a sign-based theory, cyclic effects follow in a declarative fashion from static constituent structure configurations, and
- ii) all constituent structure-based theories of linguistics possess all the tools needed to utilize the sign-based approach, since nonterminal nodes inherit some information from their daughters in all theories. There is no principled basis for excluding certain types of information from nonterminal nodes. Thus, the notion that cyclic phonology is necessarily derivational is just as mistaken as the notion that nonterminal nodes are completely devoid of features (even category features).

The fact that a mother node's phonology may differ from its daughters' phonologies is no more derivational than, for example, the fact that a mother node's syntactic category feature may be different from the syntactic category of some of its daughters.

This declarative way of deriving cyclic effects from constituent structures turns out to have a number of theoretical and empirical advantages over alternative approaches. The rest of the work is devoted to exploring these advantages, and developing Sign-Based Morphology in more detail.

3.2.2 The item-and-process connection

The most important aspect in which the realizational view of morphology differs from the more common (at least among phonologists) constituent structure-based view is in its treatment of affixes. In the traditional constituent structure view, affixes are represented as terminal nodes, just like roots, as I have been doing in this study. Realizational morphologists such as Aronoff (1976), Anderson (1990), Zwicky (1995), and Stump (1995) argue against this assumption, favoring instead an approach in which stems in the lexicon are related to other stems by “morpholexical rules”, statements of morphological operations. Affixal material is not listed in the lexicon. It is rather introduced by morpholexical rules. Advantages of this model include successful handling of nonconcatenative morphology such as truncation, for which a pure item-and-arrangement representation is impossible.

Because I have presented Sign-Based Morphology by taking Lieber’s (1980) constituent structure view of morphology, the reader may think that it is inconsistent with a realizational view of morphology, and is therefore subject to all the criticisms of item-and-arrangement models. This, however, is not true, as I show in this section. Although I have been using constituent structures as convenient notational devices, Sign-Based

Morphology is in fact quite close in spirit to realizational views of morphology. I start with a discussion of the representation of affixes in Sign-Based Morphology. First, however, I present a schematic representation of a compound structure. This will serve as a point of reference for some of the basic architectural elements of Sign-Based Morphology in the following discussion of affixes.

(80) Representation of compounds

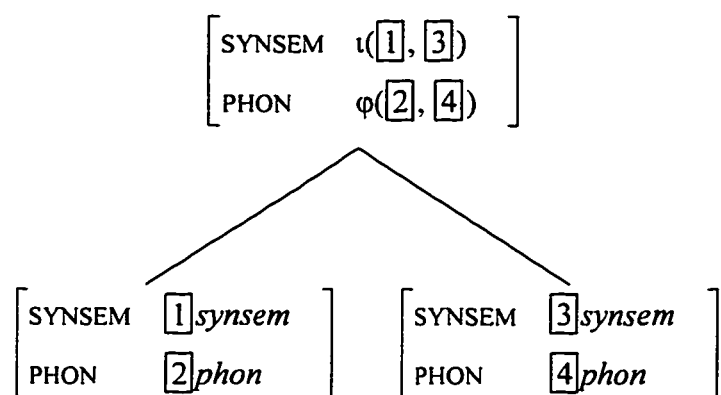

Much of the following discussion of affixation in Sign-Based Morphology will be concerned with the nature of φ , the phonological constraint system that relates a mother node's phonology to its daughters' phonologies.

Affixes can be treated in three different ways in Sign-Based Morphology. These are summarized in (81):

- (81)
- a) Affixes are terminal constituents (item-and-arrangement).
 - b) Affixal material is introduced by φ (item-and-process).
 - c) Affixes are fixed arguments to φ specified in affixation constructions.

I will discuss these three options in this section. Although I have used option (81a) so far in this study due to its visual appeal, I will in fact come down in favor of (81c). All options handle concatenative morphology equally well, differing only in their treatment of nonconcatenative morphology.

In the first approach (81a), affixes are represented as terminal nodes, in the same way as roots are. Thus, the construction that adds the Turkish plural suffix *-ler* to a noun would be represented as in (82):

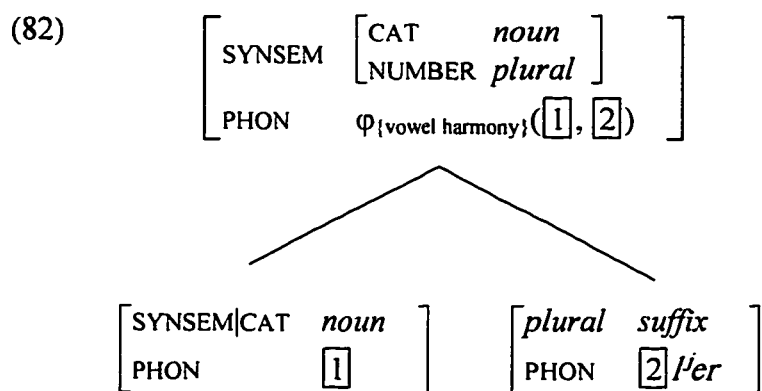

In (82) the indices $\boxed{1}$ and $\boxed{2}$ indicate identity. The subscript annotation on the function φ is a reminder to the reader that indicates some of the phonological alternations enforced by φ , in this case, vowel harmony. In (83), I show a word (*atlar* ‘horses’) licensed by this affixation construction:

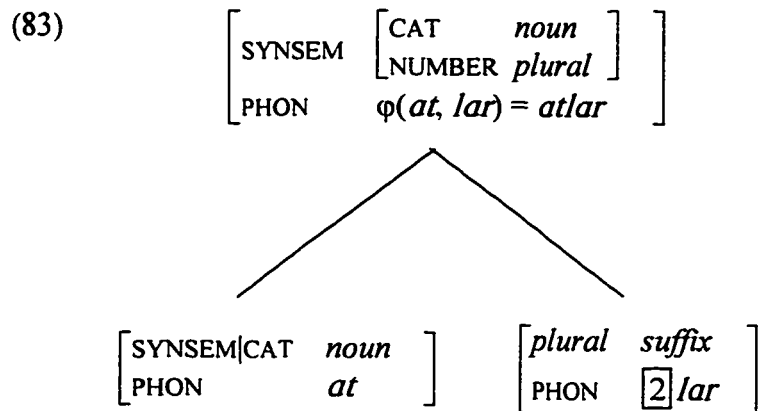

It should be noticed that the terminal node corresponding to the affix is somewhat redundant: all the information contained in this node that is relevant to the surface form is found in the mother node as well. Thus, it should be possible to eliminate the affix node altogether, and encode the relevant information directly in the mother node, a point made by Riehemann 1994 and Koenig 1994. This move would also have various advantages, including the following: there would be no need to choose between “zero affixes” and morphological conversion constructions (i.e., affixless morphological constructions)—the two would be indistinguishable. In the item-and-arrangement approach (where affixes are represented as terminal constituents), it is possible to contrast analyses with phonologically null affixes with analyses with unary dominance (no affix). Consider, for example, zero-derived denominal verbs in English (84):

(84)	<u>Noun</u>	<u>Verb</u>
	table	table
	chair	chair
	cage	cage
	frame	frame

If we represent affixes as terminal nodes, we have two options for the representation of the construction that licenses the forms in (84). We could either represent the construction with a zero affix (85a), or with no affix (85b):

(85) a) zero affix

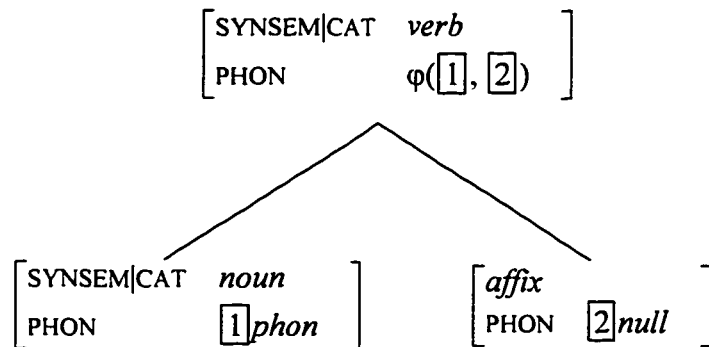

b) no affix²⁶

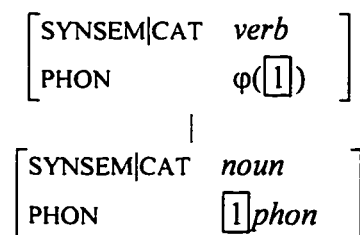

If we do not represent affixes as terminal nodes to begin with then this arbitrary choice between zero morphology as zero affixation versus zero morphology as unary dominance does not arise. Unary (nonbranching) dominance is the only choice. This is a desirable property for a formal approach to morphology to have, as arbitrary choices should be avoided in principle (see Pullum and Zwicky 1991 for other strong arguments against

²⁶ The vertical line connecting the nodes in structures such as this one represents nonbranching dominance. That is, the lower node in such structures is the sole immediate constituent of the higher node.

approaches to morphology that use or even allow zero affixes). In the affixes-as-terminal nodes approach, zero affixes could of course be ruled out by stipulation, but to the extent that ruling things out by architecture is more desirable than ruling things out by fiat, the approach in (85) is preferred.

A further advantage of representing affixation in terms of unary dominance constructions is that there is no need to make a formal difference between concatenative and nonconcatenative morphology—the only difference between the two would be in the nature of the phonological mapping φ . In this approach, the Turkish pluralization construction would be as shown in (86):

$$(86) \quad \left[\begin{array}{l} \text{SYNSEM} \quad \left[\begin{array}{l} \text{CAT} \quad \textit{noun} \\ \text{NUMBER} \quad \textit{plural} \end{array} \right] \\ \text{PHON} \quad \varphi \{ \textit{concatenate /lEr/}; \textit{vowel harmony}; (\boxed{1}) \} \end{array} \right]$$

$$\quad \quad \quad |$$

$$\quad \quad \quad \left[\begin{array}{l} \text{SYNSEM} | \text{CAT} \quad \textit{noun} \\ \text{PHON} \quad \quad \quad \boxed{1} \end{array} \right]$$

The structure of the word *atlar* would then be as in (87):

$$(87) \quad \left[\begin{array}{l} \text{SYNSEM} \quad \left[\begin{array}{l} \text{CAT} \quad \textit{noun} \\ \text{NUMBER} \quad \textit{plural} \end{array} \right] \\ \text{PHON} \quad \varphi(\textit{at}) = \textit{atlar} \end{array} \right]$$

$$\quad \quad \quad |$$

$$\quad \quad \quad \left[\begin{array}{l} \text{SYNSEM} | \text{CAT} \quad \textit{noun} \\ \text{PHON} \quad \quad \quad \textit{at} \end{array} \right]$$

This approach is equivalent to a “realizational” conception of morphology (e.g., Anderson 1992, Janda 1983, Stump 1995, Zwicky 1994), in which morphemes are “rules” rather

than “things”. However, this conception has a serious drawback: Phonology in this approach has to be able to insert arbitrary amounts of material (corresponding to affixes). Such phonological rules are unnatural, and should be avoided in principle. This is especially true because deletion or other kinds of prosodic circumscription (McCarthy and Prince 1990) are restricted to a single prosodic unit (e.g., a single segment, syllable, or foot).²⁷ Such a restriction should follow from the theory of phonology (i.e., of φ). The approach to affixation represented in (86) would be hard put to answer the following question: why is deletion restricted to target a single prosodic unit, while insertion is able to target an arbitrary amount of material?

In past item-and-process inspired approaches to morphology (e.g., Anderson 1992), this problem was sidestepped by decoupling “morphological rules” from “phonological rules”. In such approaches, it is assumed that a morphological rule inserts the affix material. Regular phonological rules then apply to the resulting string. This way, phonological theory can be formulated in a principled way, without being corrupted, so to speak, by rules that insert arbitrary amounts of material. A typical derivation in such a framework may look like the following (88):

(88) a) plural suffixation (morphological rule)

$$\left[\begin{array}{l} \text{SYNSEM|NUMBER } \textit{plural} \\ \text{PHON} \quad \boxed{1} \end{array} \right] \rightarrow [\text{PHON } \boxed{1} - \textit{IEr}]$$

²⁷ There are cases of prosodic circumscription in which the circumscribed portion of a form is preserved, and the remainder is deleted (an example is given in (93)). This gives the appearance of deletion of an arbitrary amount of material. However, the fact remains that a single prosodic unit is targeted by circumscription.

b) example

input:
$$\left[\begin{array}{l} \text{SYNSEM} \left[\begin{array}{l} \text{CAT} \quad \textit{noun} \\ \text{NUMBER} \quad \textit{plural} \end{array} \right] \\ \text{PHON} \quad \textit{at} \end{array} \right]$$

output of plural suffixation:
$$\left[\begin{array}{l} \text{SYNSEM} \left[\begin{array}{l} \text{CAT} \quad \textit{noun} \\ \text{NUMBER} \quad \textit{plural} \end{array} \right] \\ \text{PHON} \quad \textit{at + lEr} \end{array} \right]$$

output of phonology:
$$\left[\begin{array}{l} \text{SYNSEM} \left[\begin{array}{l} \text{CAT} \quad \textit{noun} \\ \text{NUMBER} \quad \textit{plural} \end{array} \right] \\ \text{PHON} \quad \textit{atlar} \end{array} \right]$$

This solution is derivational and is therefore not readily available in Sign-Based Morphology, where a single function ϕ declaratively relates the daughter and mother node phonologies. Whatever insertion of phonological material there is has to be performed by ϕ . Decoupling phonological epenthesis from “morphological insertion” would require creation of another attribute, which we may call MORPH, which has as its value the result of the “morphological rule”. Example (89) illustrates an implementation of this in what may still be considered a typical Andersonian system.

(89) a) Revised morphological rule

$$\left[\begin{array}{l} \text{SYNSEM} | \text{NUMBER} \textit{plural} \\ \text{MORPH} \quad \boxed{1} \end{array} \right] \rightarrow [\text{MORPH} \boxed{1} \textit{-lEr}]$$

input:

$$\left[\begin{array}{l} \text{SYNSEM} \left[\begin{array}{l} \text{CAT} \quad \textit{noun} \\ \text{NUMBER} \quad \textit{plural} \end{array} \right] \\ \text{MORPH} \quad \boxed{1} \textit{at} \\ \text{PHON} \quad \varphi(\boxed{1}) = \textit{at} \end{array} \right]$$

output of plural suffixation:

$$\left[\begin{array}{l} \text{SYNSEM} \left[\begin{array}{l} \text{CAT} \quad \textit{noun} \\ \text{NUMBER} \quad \textit{plural} \end{array} \right] \\ \text{MORPH} \quad \boxed{1} \textit{at} + \textit{lEr} \\ \text{PHON} \quad \varphi(\boxed{1}) = \textit{atlar} \end{array} \right]$$

As stated, this approach is still derivational: it takes a plural stem lacking the proper morphological expression of the plural feature, and then adds the plural morph to it. A nonderivational account would license the plural form directly in terms of static constraints on constituent structure. This can be done by formulating a plural construction that takes a bare noun stem as a daughter node and requires the presence of the plural suffix material in the mother's MORPH value (90):

(90) a) Pluralization construction

$$\left[\begin{array}{l} \text{SYNSEM} \left[\begin{array}{l} \text{CAT} \quad \textit{noun} \\ \text{NUMBER} \quad \textit{plural} \end{array} \right] \\ \text{MORPH} \quad \boxed{2}(\boxed{1} \sim \textit{lEr}) \\ \text{PHON} \quad \varphi(\boxed{2}) \end{array} \right]$$

$$\begin{array}{c} | \\ \left[\begin{array}{l} \text{SYNSEM} | \text{CAT} \quad \textit{noun} \\ \text{PHON} \quad \quad \quad \boxed{1} \end{array} \right] \end{array}$$

b) example

$$\left[\begin{array}{l} \text{SYNSEM} \\ \text{MORPH} \\ \text{PHON} \end{array} \left[\begin{array}{ll} \text{CAT} & \textit{noun} \\ \text{NUMBER} & \textit{plural} \end{array} \right] \right]$$

$$\left[\begin{array}{l} \text{MORPH} \\ \text{PHON} \end{array} \right] \text{ (at + lEr)}$$

$$\left[\begin{array}{l} \text{PHON} \\ \text{PHON} \end{array} \right] \varphi(\text{at + lEr}) = \textit{atlar}$$

$$\left[\begin{array}{l} \text{SYNSEM} \\ \text{PHON} \end{array} \left[\begin{array}{ll} \text{CAT} & \textit{noun} \\ & \textit{at} \end{array} \right] \right]$$

We now have an approach that has the following properties:

- i) affixes are not constituents
- ii) affix material is not inserted by φ .

This approach successfully decouples insertion of phonological material by the morphology (such insertion is specified as part of the MORPH value in affixation constructions) from insertion of phonological material by the phonology (such insertion is handled by the phonological mapping φ). This decoupling puts us in a good position to develop a principled phonological theory that does not need to lose insights because of the necessity to incorporate arbitrary insertion rules. However, the representation in (89) suffers from a degree of unwanted redundancy. The MORPH value is entered as an argument to the phonological function φ . The sole function of the MORPH attribute is to assemble the appropriate argument to φ . It would be possible, and more desirable, to introduce affixal material directly as a fixed argument to φ in affixation construction. We could then eliminate the MORPH attribute, which has very low utility. There is a way to do this in Sign-Based Morphology: we posit a fixed element in the input-phon list of

affixation constructions. This fixed element corresponds to the “underlying” form of the affix. This is done for the Turkish pluralization construction in (91):²⁸

$$(91) \quad \left[\begin{array}{l} \text{SYNSEM} \left[\begin{array}{l} \text{CAT} \quad \textit{noun} \\ \text{NUMBER} \quad \textit{plural} \end{array} \right] \\ \text{PHON} \quad \varphi_{\{\text{vowel harmony}\}}(\boxed{1}, /Er) \end{array} \right]$$

$$\quad \quad \quad |$$

$$\quad \quad \quad \left[\begin{array}{l} \text{SYNSEM} | \text{CAT} \quad \textit{noun} \\ \text{PHON} \quad \quad \quad \boxed{1} \end{array} \right]$$

This approach to affixation incorporates the insights, and avoids the pitfalls, of both of the approaches we have seen before. Like the realizational approach (but unlike the affixes-as-lexical items approach), it does not suffer from redundancy and a certain degree of arbitrariness regarding zero affixes. Like the affixes-as-lexical items approach (but unlike the realizational approach), it does not interfere with the development of a properly restrictive theory of phonology that does not have the capability to insert arbitrary amounts of phonological material. The structure of the Turkish plural noun *atlar* is now as shown in (92):

²⁸ Although I claim that this approach is superior to the item-and-arrangement approach in which affixes are represented as terminal constituents, it may be argued that the difference between these approaches is mainly notational. In particular, the item-and-arrangement approach suggests (wrongly) that affixes are signs, just like stems (see Riehemann 1994 for more on this point). As long as it is kept in mind that affixes are not meant to be independent lexical items, no harm is done by using a notation in which they are represented as terminal nodes. Since such a notation is visually more appealing, I will in fact continue using it in the rest of this work.

$$(92) \quad \left[\begin{array}{l} \text{SYNSEM} \left[\begin{array}{l} \text{CAT} \quad \textit{noun} \\ \text{NUMBER} \quad \textit{plural} \end{array} \right] \\ \text{PHON} \quad \varphi(\textit{at}, \textit{IEr}) = \textit{atlar} \end{array} \right] \\ \quad \quad \quad | \\ \quad \quad \quad \left[\begin{array}{l} \text{SYNSEM} | \text{CAT} \quad \textit{noun} \\ \text{PHON} \quad \quad \quad \textit{at} \end{array} \right]$$

This approach preserves all the advantages of using constituent structures, primary among which is the desire to have a uniform representation for syntax and morphology (while not disregarding their differences, of course).²⁹ The Structuralists treated syntax and morphology in the same way, applying their item-and-arrangement and item-and-process models to both. In the recent Government and Binding tradition and its descendants, including the Principles and Parameters theory and Minimalism, the desire to treat syntax and morphology in the same way is a major (though by no means unanimously agreed upon) driving force (especially Baker 1988 and Lieber 1992). Criticisms of the methodological stance of trying to make syntax and morphology similar are based mostly on the disadvantages of the item-and-arrangement nature of most existing theories, and,

²⁹ I claim that the differences between syntax and morphology are partly due to the fact that syntax deals mostly with free constituents (that is, elements that can participate in a variety of constructions), while morphology mostly deals with bound elements (those represented as constructions). Although this issue is very involved and cannot possibly be resolved in a one-volume work, note that there is a precedent to this kind of reasoning in Riehemann's sign-based approach to morphology. She rejects the word-syntactic approach of Krieger and Nerbonne 1993 in favor of a construction-based approach that is quite similar to Sign-Based Morphology. Krieger and Nerbonne 1993 represent affixes as independent lexical entries that have a valence requirement for the appropriate host. Usual x-bar schemas then combine affixes with their hosts. As Riehemann points out, this approach predicts that syntactic effects such as dislocation and ellipsis of constituents should be possible in morphology as well. This is of course not true. The lack of such effects follows immediately from the fact that affixes are represented as constructions rather than as independent lexical

to an important extent, disadvantages of assuming that affixes are heads, a common property of many approaches to morphology. Sign-Based Morphology satisfies the desire for uniformity, but is not subject to the problems of traditional item-and-arrangement models. For example, truncation, one of the most serious problems for item-and-arrangement models, is handled in Sign-Based Morphology in exactly the same way affixation is. The only difference is in the phonological constraint system φ . Consider, for example, the English nickname formation process which truncates personal names to one syllable (analyzed in Optimality Theory by Benua 1995), as in *Rich* from *Richard*. The Sign-Based Morphological representation of this form is shown in (93):

$$(93) \quad \begin{array}{c} [\text{phon } \varphi(\text{ɹɪtʃə}d) = \text{ɹɪtʃ}] \\ | \\ [\text{phon } \text{ɹɪtʃə}d] \end{array}$$

The assumption that affixes are heads cannot be held in any version of Sign-Based Morphology, since flat structures involving multiple affixes are allowed. The most natural position to hold is that (at least some) morphological constructions are headless. See Koenig, Orgun and Jurafsky 1996 for discussion of this point.

Not all of the advantages of assuming a constituent structure-based approach to morphology are methodological or aesthetic, however. Sign-Based Morphology does share a lot with realizational views of morphology, but it has one marked empirical advantage: it deals with noncyclic phonological effects without difficulty, and relates them to independently motivated morphological structures. While realizational

entries: the construction-based representation ensures that affixes must always occur

approaches derive cyclic phonological effects with equal elegance to Sign-Based Morphology, it is not clear how they would relate the cyclic-noncyclic contrast to independently motivated morphological structures (since such approaches, in general, reject the very existence of morphological structure).

In conclusion, Sign-Based Morphology offers a unique amalgamation of insights and advantages from constituent structure-based and realizational approaches to morphology, showing first that the two approaches are not as different as usually assumed, and, secondly, that it is possible to have the best of both worlds.

3.3 The sign-based connection

This section explores the connections between Sign-Based Morphology and other sign-based theories of linguistics.

In this section, I also make some of the connections between Sign-Based Morphology and unification-based theories of linguistics such as HPSG (Pollard and Sag 1987, Pollard and Sag 1994) and Construction Grammar (Fillmore and Kay 1994, Fillmore and Kay 1996) somewhat more explicit.

The basis of Sign-Based Morphology is the “local tree”, that is, a mother node and its immediate constituents. All grammatical constructions are stated as constraints on local trees that they license.³⁰ A constituent structure is wellformed if and only if all the

attached to stems.

³⁰ It is possible that “extended family” constructions (that is, constructions that mention more levels of constituents than just a mother and its daughters) are necessary, as argued by Fillmore et al. 1988. In Sign-Based Morphology, the restriction of constructions to local trees derives a means to handle Bracket Erasure effects (chapter 5). If extended family constructions are allowed, the insights regarding Bracket

local trees in it are wellformed (i.e., licensed by grammatical constructions or lexical items). The structure of a generic local tree is shown in (94):

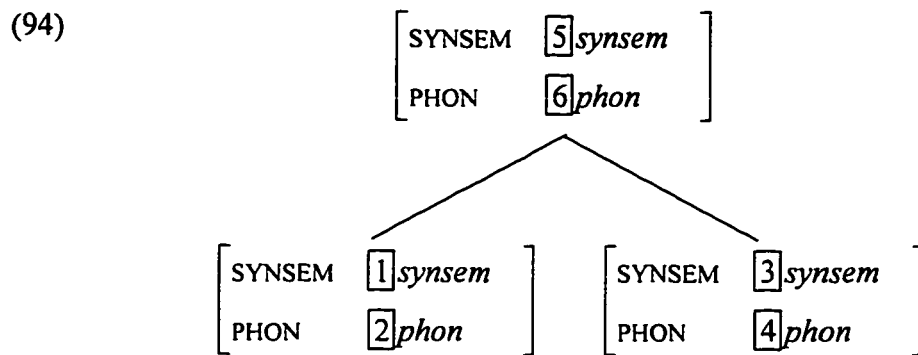

Each node in (94) is a sign, that is, a Saussurean pairing of meaning (the value of the SYNSEM attribute) and form (the value of the PHON attribute). The dependency between the mother and daughter node features is handled by a set of constraints. A number of such constraints have been proposed in the unification-based grammar literature; the “Head Feature Principle” of HPSG (Pollard and Sag 1987, Pollard and Sag 1994) is one. For visual perspicuity, it is convenient to express this dependency as a function, as in (95):

Erasure effects can still be preserved by restricting phonology to refer only to the PHON attributes of the immediate constituents.

(95)

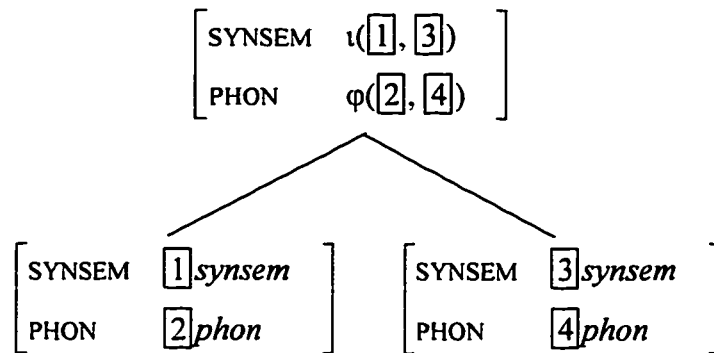

This notation should not be taken to imply that the mother node's features are derived from the daughter nodes' features. It is simply a statement that there exist a number of grammatical constraints such that any given triplet of signs will either be licensed (accepted as wellformed) or rejected.³¹ The function notation also makes clear the mutual dependency between the mother node and the set of daughter nodes: Assume that the grammatical construction to license this local tree is known. Then, given the daughter nodes, there will be only one possible sign for the mother node that will be licensed (modulo free or stylistic variation). Similarly, given the mother node, there will be a unique set of daughter nodes that will be licensed (modulo ambiguity). The grammar is thus nonderivational. It can be used both for production and processing, but does not favor either over the other, a common property of declarative grammars. The function notation will be used in the rest of this study. It should be kept in mind that a directional

³¹ This view has also been adopted by Kathol (1995), who offers a formal account. Briefly, the notion of licensing a sign σ_1 amounts to saying that σ_1 is a morphologically simple lexical entry (a bare root) or that there are signs σ_2 and σ_3 (assuming binary branching constituent structures; for n -ary branching structures, we need to have n signs) such that $\mathfrak{R}(\sigma_1, \sigma_2, \sigma_3)$ holds for a relation \mathfrak{R} from a finite set of possible licensing relations (which I am calling "constructions" in this work).

application is never meant by this; the correct interpretation is always in terms of constraints holding over lists of signs.

3.4 Sign-Based Morphology how-to

3.4.1 Compounding

Compounding is the simplest type of morphological construction to handle in that there is general agreement among linguists on the right way to deal with it. All theories of morphology deal with compounding as a construction that relates three items. Two of these three items are the stems or words that are members of the compound, and the third is the resulting compound stem or word. In Sign-Based Morphology, this is expressed by a construction whose daughter nodes are the stems that are compounded (96):

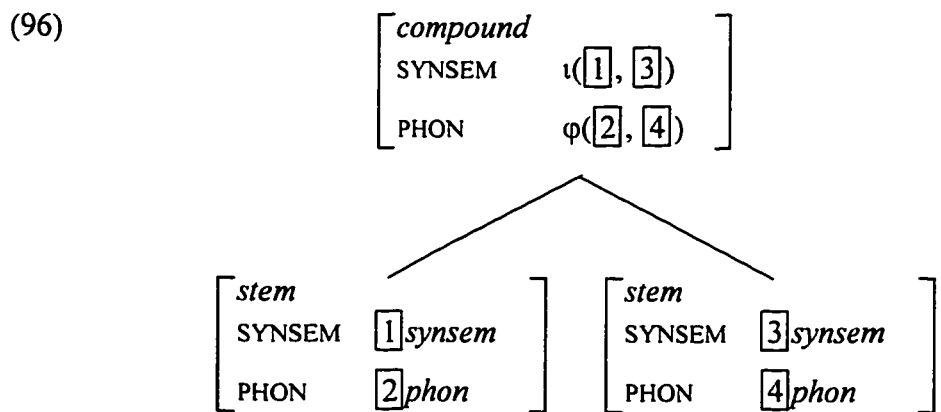

The annotation in italics in the upper left hand corner of signs identifies the lexical type that the sign is an example of. Types will be discussed more fully in section 5.2.3. For now, it suffices to say that every object (all signs and constructions, as well as all attribute values) is typed. The compounding construction in (96) requires its daughters to be of

type *stem*, and specifies the mother node as of type *compound* (which is a subtype of *stem*, since, in general, compounds may be members of a bigger compound, as in the Mandarin examples in section 1.1). The examples of cyclic phonological effects in Mandarin tone sandhi in section 1.1 had to do with compounding. The reader may wish to refer back to those examples of the sign-based representation of actual compound words.

3.4.2 Affixation

The representation of affixes is slightly more challenging than compounding. With affixes, it is necessary to provide not just a description of the affixal material, but also some statement of what class of stems the affix can attach to. This was not necessary in the case of compounding, since the members of a compound are ordinarily free stems, that is, stems that can occur in a variety of contexts, and, usually, can be used as words on their own without further morphology. Affixes, on the other hand, must, by definition, always attach to a stem. If we were to provide affixes with a lexical entry, we would also need a construction that attaches the affix to the appropriate type of base. For example, for the English plural morpheme, we might posit the following lexical entry and construction (97):

(97) a) Lexical entry

<i>noun suffix</i> SYNSEM NUM PHON	<i>plural</i> <i>z</i>
--	---------------------------

b) Construction

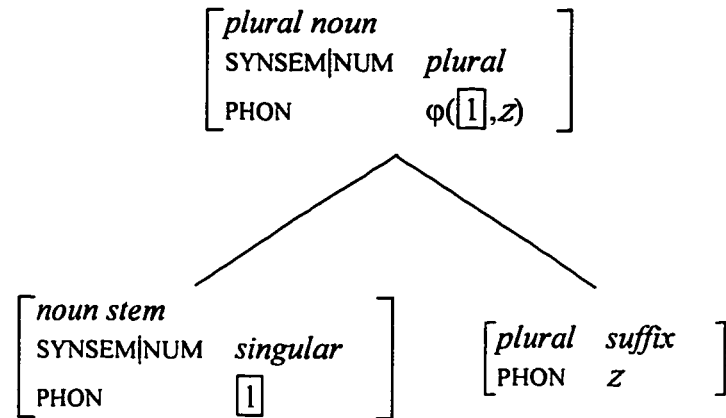

At this point, it should be clear that the lexical entry in (97a) serves no purpose at all. The construction in (97b) contains all the information necessary to represent the affix material as well as the attachment requirements of the affix. Accordingly, affixes are represented as constructions as in (97b) in Sign-Based Morphology. The inclusion of a terminal node corresponding to the affix in affixation constructions is somewhat misleading. In particular, it suggests that the affix is still being represented as a sign. This is not intended, however. The affix has no life outside of the construction. It is not listed as an independent lexical item by itself. In section 3.2.2, I have shown how it is possible and desirable to eliminate the terminal node corresponding to the affix in (97b). This move brings Sign-Based Morphology closer to realizational views of morphology. However, I will continue using the representation in (97b) due to its greater visual appeal. The reader interested in the issue of item versus process based views of morphology may wish to refer back to section 3.2.2. It will then be a simple matter of typographic substitution to

convert the apparently item based representations in this work to representations in which affixes are not items.

The idea of representing affixes as constructions is in the same spirit as the “subcategorization frames” used in past constituent structure-based theories of morphology such as that of Inkelas 1988. The same idea has already been used in sign-based linguistics by Riehemann 1993, 1994. We will see that a number of empirical predictions follow from this choice, and are supported by data from a variety of languages.

3.4.3 Nonconcatenative morphology

Nonconcatenative morphology is often argued to be a problem for constituent structure-based views of morphology (e.g., by Janda 1983, Anderson 1992). Indeed, the otherwise well worked-out theory of Lieber 1980 has no satisfactory way of dealing with nonconcatenative morphology, but instead relegates it to a separate, “transformational”, component of the lexicon, while concatenative morphology is handled in the simple phrase structure component. This difficulty faced by past constituent structure-based approaches is, however, not intrinsic to using constituent structures. Rather, it is a consequence of the ill-advised choice of terminal based constituent structures. That is, it is Lieber’s arbitrary decision to single out phonology as the only type of information that is outside the scope of percolation that forces her to posit a separate transformational lexical component to handle nonconcatenative morphology. As I show in this section,

Sign-Based Morphology does not run into this problem, thanks to its sign-based architecture.

Let us start with infixation, a type of nonconcatenative morphology for which a workable terminal-based representation has been proposed by McCarthy 1979. We will later move on to more challenging types of nonconcatenative morphology. The data in (98) illustrate infixation in Tagalog. The data come from Schachter and Otones 1972. The analysis follows McCarthy and Prince 1993.

(98)	Verb	Nominal	Gloss
	aral	umaral	'teach'
	sulat	sumulat	'write'
	gradwet	grumadwet	'graduate'

The constituent structure for *umaral* is shown in (99). This is a case of simple prefixation.

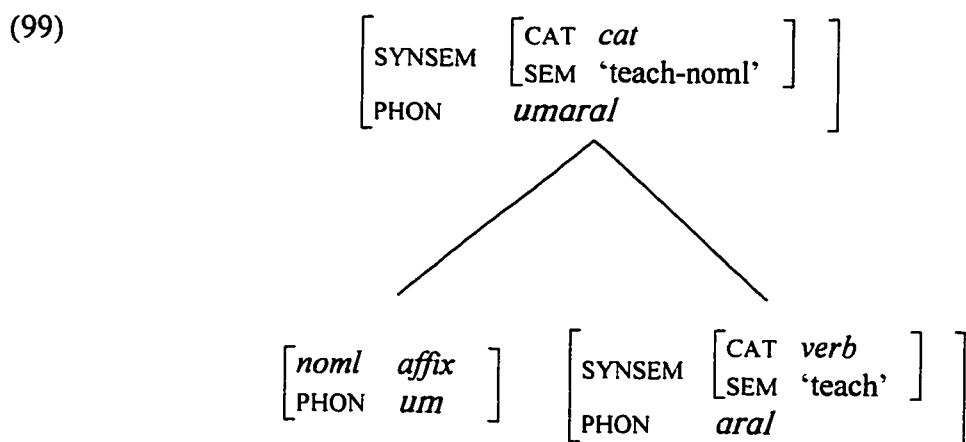

Now, let us consider the constituent structure for the infixated form *sumulat* (100):

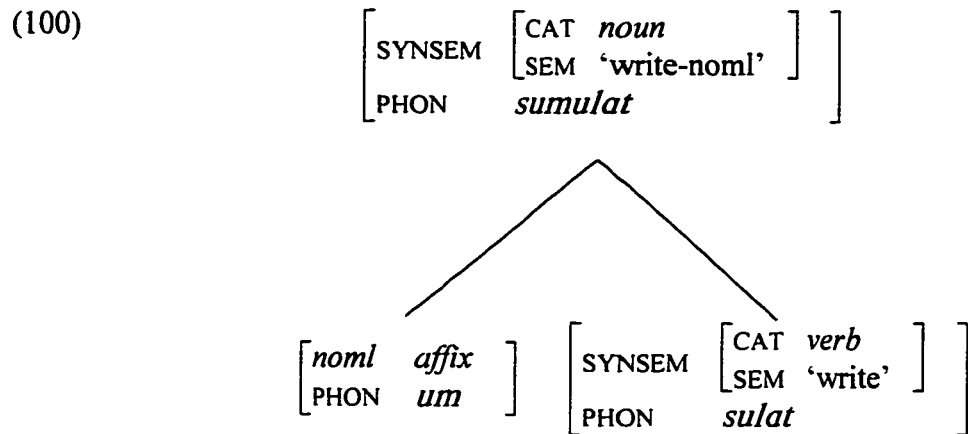

Comparing (99) and (100) reveals no great difference between prefixation and infixation.

Both are licensed by the *um* construction in (101):

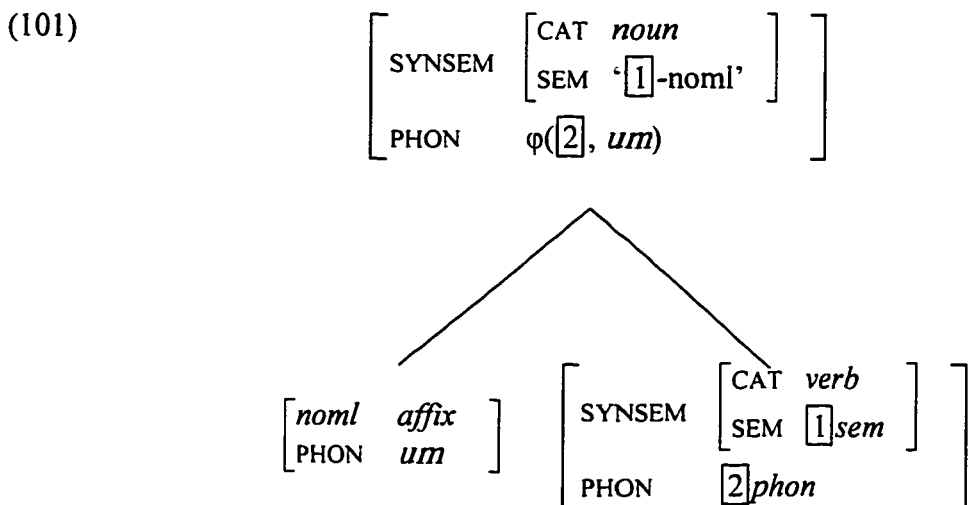

The only challenge is to define φ in such a way as to enforce prefixation and infixation of *um* as appropriate. An Optimality Theory account of this phenomenon can be found in McCarthy and Prince 1993 and Orgun and Sprouse 1996a,b. I offer a summary of McCarthy and Prince's analysis here.

The main idea is that *um* is basically a prefix. This is expressed by an alignment constraint requiring *um* to appear at the left edge. This constraint is outranked by syllable-structure constraints (in particular, by a constraint against closed syllables). As a result, *um* is infixated at the expense of an alignment violation when doing so will result in better overall syllable structure. The constraints are summarized in (102):

- (102) ALIGN(*um*, L, stem, L) *um* is a prefix
 NOCODA syllables must be open

Ranking: NOCODA » ALIGN-*um*

The tableau in) shows how this ranking accounts for the prefixation of *um* on vowel initial stems (e.g., *umaral*), and its infixation into consonant-initial stems (e.g., *sumulat*):

(103)

/um + aral/	NOCODA	ALIGN- <i>um</i>
☞ umaral	*	
arumal	*	*!*

/um + sulat/	NOCODA	ALIGN- <i>um</i>
umsulat	**!	
☞ sumulat	*	*
sulumat	*	**!*

This approach to nonconcatenative morphology extends readily to nonaffixal morphology of all types. Consider as an example the English nickname formation process for which Benua 1995 has presented an Optimality Theory analysis (but in a different

morphological theory). In this construction, the input name is truncated to one syllable

(104):

(104)	Richard	Rich
	Thomas	Tom
	William	Will
	Patrick	Pat

The constituent structure I assume for *Rich* is shown in (93):

(105)	$\left[\begin{array}{l} \text{SYNSEM CAT} \quad \textit{proper noun} \\ \text{PHON} \quad \quad \quad \textit{ɹɪtʃ} \end{array} \right]$
	$\left[\begin{array}{l} \text{SYNSEM CAT} \quad \textit{proper noun} \\ \text{PHON} \quad \quad \quad \textit{ɹɪtʃəd} \end{array} \right]$

The nickname formation construction that licenses this form is depicted in (106):

(106)	$\left[\begin{array}{l} \text{SYNSEM CAT} \quad \textit{proper noun} \\ \text{PHON} \quad \quad \quad \varphi(\boxed{1}) \end{array} \right]$
	$\left[\begin{array}{l} \text{SYNSEM CAT} \quad \textit{proper noun} \\ \text{PHON} \quad \quad \quad \boxed{1}\textit{phɒn} \end{array} \right]$

Once again, the only challenge is to devise the appropriate φ . See Benua 1995 for an extensive discussion of the necessary constraint ranking.

We have seen that, unlike terminal-based constituent structure approaches, Sign-Based Morphology runs into no difficulty handling nonconcatenative morphology. The only difference between concatenative and nonconcatenative morphology is in the phonological function φ , a matter for phonological theory. In this work, I have presented,

and will continue to present, Optimality Theoretic analyses of most of the phonological alternations considered. However, Sign-Based Morphology is compatible with any declarative theory of morphology.

3.4.4 What is a morpheme?

In this section, I discuss the issue of what a morpheme is from the perspective of Sign-Based Morphology. Essentially, there are two types of morphemes: free roots, which, like morphologically or syntactically complex forms, are signs. Free roots are listed lexically as signs, while complex forms are licensed by constructions that paradigmatically relate them to other (simple or complex) signs. Complex forms may also be listed, of course, in analyzed form if desired. Such listing of complex forms is necessary in the case of noncompositionality, and may be desirable from a psycholinguistic perspective even for some perfectly compositional forms. Bound morphemes (affixes and clitics, and perhaps bound roots as well), on the other hand, are listed as constructions that specify the daughter node (the stem that the affix attaches to) as well as the mother node (the form that the affixation construction licenses).

Sign-Based Morphology appears in one respect to differ from realizational views of morphology: such views often reject the existence of bound morphemes (especially affixes)—the name of Anderson's A-morphous Morphology reflects this position. In Sign-Based Morphology, the claim is that affixes do exist, but only as constructions, not as lexical entries (signs). This is in fact quite similar to the realizational view, where the

role of affixes is taken over by morpholexical rules. Sign-Based Morphology's affixation constructions can be seen as a nonderivational version of morpholexical rules.

The issue of what a morpheme is from the perspective of a unification-based theory of grammar has been taken up previously by Rhodes (1992). The approach I present here is similar to his, except that I make a clearer distinction between roots and affixes.

A root is essentially a simple sign, that is, a sign with no constituents (107):

(107) A root (morphologically simple stem)

<i>root</i>	
SYNSEM	<i>synsem</i>
PHON	<i>phon</i>

A morphologically complex stem, on the other hand, is a sign that has one or more immediate constituents (108) (where the Kleene + notation indicates one or more signs).³²

³² The ellipses are meant to indicate that the list of arguments to the semantic and phonological mappings will contain the semantic and phonological information in each daughter.

(108) A morphologically complex stem

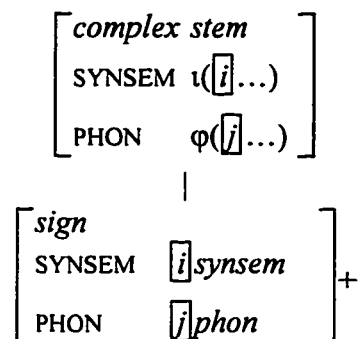

An affix is represented as a construction. This is equivalent to representing affixes as partially specified complex stems in which one daughter is unspecified. A fixed argument to the phonological function φ represents the phonological material contributed by the affix (109) (the element indicated as $\boxed{3}$ represents the phonological material contributed by the affix):

(109) An affix

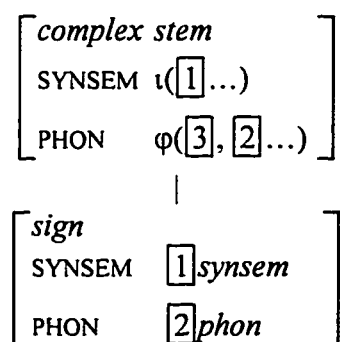

Affixation can then be seen as unification of a sign (root or complex form) with the daughter node of a construction like the one in (109).

What is a morpheme? A root morpheme is a simple sign (that is, one with no daughters). An affix is a construction (that is, a partially specified sign—one with an unspecified daughter). In the paradigmatic interpretation of Sign-Based Morphology, this amounts to saying that an affix is a function from a (simple or complex) sign to a (complex) sign.

3.5 Comparison of Sign-Based Morphology with paradigmatic approaches to morphology

In this section, I compare Sign-Based Morphology to some competing approaches to the phonology-morphology interface that use some sort of paradigm uniformity constraint as their basic tool of handling cyclic phonological effects. I discuss the basics of three types of approaches to morphology that use paradigm uniformity. I call these:

- i) strictly paradigmatic approaches,
- ii) loosely paradigmatic approaches,
- iii) syntagmatic approaches enriched with transderivational identity constraints.

3.5.1 Strictly paradigmatic approaches

Strictly paradigmatic approaches are those that relate all words within a paradigm to each other in one rule or constraint, rather than relating them to each other in pairs, such that a separate rule or constraint system is used to relate each pair. Furthermore, these approaches take an all-encompassing definition of paradigm that allows words that share any morphological property to define a paradigm. For example, in a strictly paradigmatic

approach, not only do the words *read, reads, reading, reader, unread*, etc. form a paradigm, but so do the words *books, cats, dogs, oranges, misgivings*, and so on. Bochner 1993 is an uncompromising example of a strictly paradigmatic approach to morphology. As an illustration of Bochner's approach to morphology, I present the rule he proposes to handle certain regularities in English *-ion* suffixation. The rule applies to paradigms containing forms that bear the suffix *-ion*:

$$(110) \left\{ \begin{array}{llll} \left[\begin{array}{l} /adXion/ \\ N \\ A \end{array} \right], & \left[\begin{array}{l} /conXion/ \\ N \\ B \end{array} \right], & \left[\begin{array}{l} /deXion/ \\ N \\ C \end{array} \right], & \left[\begin{array}{l} /disXion/ \\ N \\ D \end{array} \right], \\ \left[\begin{array}{l} /exXion/ \\ N \\ E \end{array} \right], & \left[\begin{array}{l} /inXion/ \\ N \\ F \end{array} \right], & \left[\begin{array}{l} /interXion/ \\ N \\ G \end{array} \right], & \left[\begin{array}{l} /introXion/ \\ N \\ H \end{array} \right], \\ \left[\begin{array}{l} /obXion/ \\ N \\ I \end{array} \right], & \left[\begin{array}{l} /perXion/ \\ N \\ J \end{array} \right], & \left[\begin{array}{l} /preXion/ \\ N \\ K \end{array} \right], & \left[\begin{array}{l} /proXion/ \\ N \\ L \end{array} \right], \\ \left[\begin{array}{l} /reXion/ \\ N \\ M \end{array} \right], & \left[\begin{array}{l} /subXion/ \\ N \\ N \end{array} \right], & \left[\begin{array}{l} /transXion/ \\ N \\ O \end{array} \right] & \end{array} \right\}$$

By substituting a fixed string for the variable X, we obtain a set of words. This rule captures the crucial property of *-ion* suffixation that we have already noted, namely, the uniformity of allomorphy across forms containing the same root: since the variable X need not be specified as a single morpheme, the effects of allomorphy will be copied throughout the paradigm by copying the string corresponding to X. For example, in the paradigm for *exclamation, proclamation, reclamation*, the variable X is specified to be the string *clamat* (note that most of the analyses in Bochner's work are stated in terms of orthography). The capital letter symbols underneath the phonological form represent the

syntactic and semantic features of the words, here left blank because Latinate bound roots ordinarily do not make a reliable semantic contribution to the words they appear in.

3.5.2 Loosely paradigmatic approaches

Loosely paradigmatic approaches relate words in pairs. Their paradigmatic aspect comes from the assumption that all related pairs of items must be independent words, and the rejection that underlying representations exist at all (in some approaches, such as Benua 1995, McCarthy 1996a, underlying representations are still used, but only for morphologically simple forms. Morphologically complex forms are related to morphologically simple forms by constraints that make no reference to underlying representations). Apart from this aspect, these approaches are more syntagmatic in spirit in that they always relate pairs of words to each other rather than deal with full paradigms. Furthermore, all these approaches stipulate that the morphologically simpler form may have an influence on the phonological shape of the more complex word, but not vice-versa. This suggests that the loosely paradigmatic approach is in fact a syntagmatic approach in which the morphologically more complex word is *derived* from the simpler word. In this sense, a loosely paradigmatic approach fits the Structuralist item-and-process mold better than it fits the word-and-paradigm mold. In a true paradigmatic approach, the relation between words in a paradigm would be symmetric, each word being just as likely to influence the other phonologically. Burzio 1994 is a good example of a loosely paradigmatic approach. The following figure represents Burzio's approach to cyclic effects:

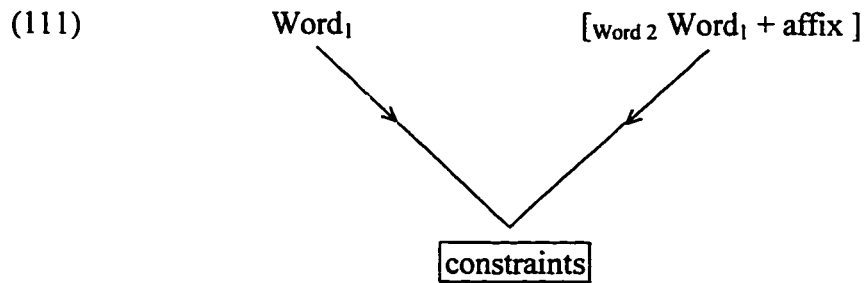

The intended interpretation of this diagram is that certain constraints relate the two words to each other. The picture makes the syntagmatic nature of the approach clear: word 2 is represented as a combination of word 1 and an affix.

Though the loosely paradigmatic approach differs in representation from Sign-Based Morphology, it is quite similar to Sign-Based Morphology in spirit: Both approaches relate forms in pairs. In both approaches, the relation between forms is stated in terms of constraints. There are two aspects in which the approaches differ: first, in Sign-Based Morphology, the relation is inherently asymmetrical. The constraints holding between a mother node and daughter node cannot have any effect on independent occurrences of the daughter node alone or in other constructions. In the loosely paradigmatic approach, constraints are taken to relate the lexical entries of two independent words. The constraints are inherently symmetrical in that they relate two independent words, rather than deriving one word from another, morphologically simpler, word. Hence the morphologically simpler word might be expected to undergo some kind of phonological change as a result of these constraints just as often as the morphologically more complex one will. Such effects are common in diachronic change involving back-formation or reanalysis, whose source is indubitably paradigmatic. For example Becker

1993 notes that some speakers of English have created a new verb, *cohesed*, by back-formation from *cohesion*. The motivation for this reanalysis is that the two morphologically related words *cohere* and *cohesion* stand in a correspondence relation. *Cohere* is just as likely to accommodate phonologically to satisfy correspondence constraints better as *cohesion* is. Indeed, in the dialect that innovated *cohesed*, greater featural faithfulness is achieved by altering the simpler word. The well-known case in Latin of *honos* > *honor* (discussed by Bochner 1993 as motivating paradigmatic morphology, though I argue that in fact it provides a strong argument against paradigmatic morphology) is another good example. As (112) shows, greater paradigmatic uniformity is achieved in Latin by altering the morphologically simpler form phonologically:

(112) Before paradigm leveling: *honos* *honoris*
 After paradigm leveling: *honor* *honoris*

This kind of outside-in effect (that is, a morphologically simpler word phonologically influenced by a morphologically more complex word) is restricted to diachronic change. Synchronic cyclic phonological effects are strictly inside-out, as predicted by Sign-Based Morphology and other theories of the phonology-morphology interface that use a relatively direct implementation of phonology-morphology interleaving.

The second difference is that Sign-Based Morphology allows noncyclic effects, which would translate, in loosely paradigmatic terms, to a structure like the one in (113).

where [Word₁ + affix₁] also exists as an independent word, but is somehow ignored in the constraints imposed on [Word₁ + affix₁ + affix₂]:

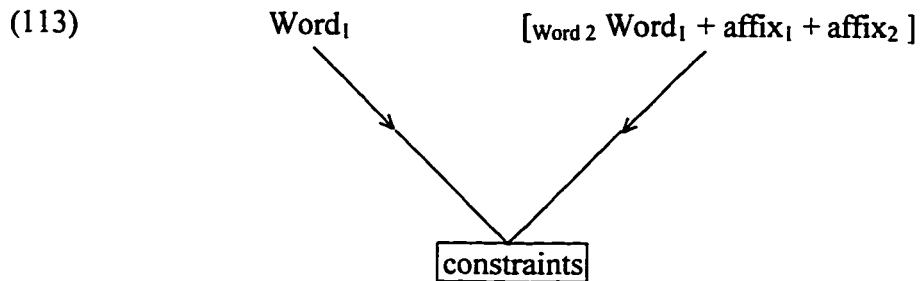

The relation between Sign-Based Morphology and the loosely paradigmatic approach is discussed more fully in section 3.5.6.

3.5.3 Syntagmatic approaches enriched with transderivational identity

The last group of approaches to morphology are not paradigmatic at all, but are included in this section because they owe a certain degree of debt to paradigmatic approaches. In these approaches, represented by Kenstowicz 1995 and Benua 1996, all surface forms are derived from their own underlying representations. But, in addition to the usual input-output faithfulness constraints, there are also transderivational identity constraints that hold between pairs of morphologically related words. The general constraint scheme of this type of approach is shown in (114):

(114) UR

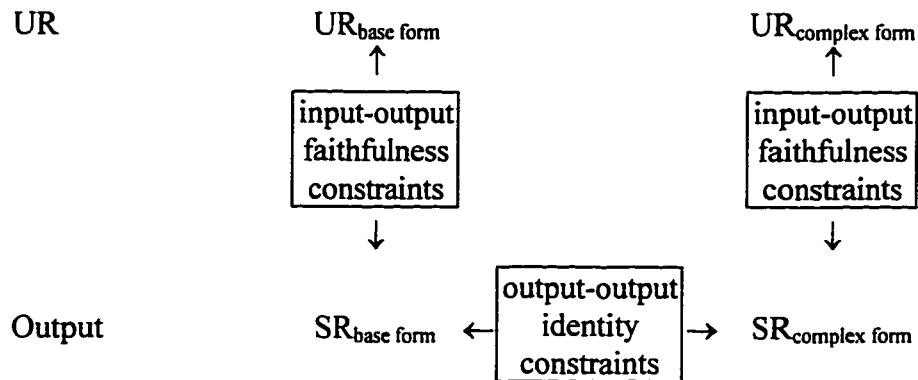

This approach is clearly less restrictive than the loosely paradigmatic approach. In addition to allowing the equivalent of a cyclic derivation, it also allows the equivalent of global reference to underlying representations. I will argue that both of these properties of the syntagmatic approach are grounds for rejecting it.

3.5.4 More on the paradigmatic interpretation of Sign-Based Morphology

Although I have presented Sign-Based Morphology as an essentially syntagmatic theory, it in fact has a quite compelling paradigmatic interpretation. In this section, I make this interpretation more explicit, in line with the general goal of this chapter of showing how Sign-Based Morphology combines insights from seemingly incompatible views of morphology. The paradigmatic interpretation of sign-based linguistics discussed in this section is similar to that proposed by Kathol (1995).

The basis of sign-based approaches to linguistics is the local tree, that is a mother node plus its immediate constituents. The distinguishing property of sign-based theories is that the mother node, just like the daughters, is a full-fledged information structure

including (at least) semantic and phonological information. This basic structure is depicted in (115):

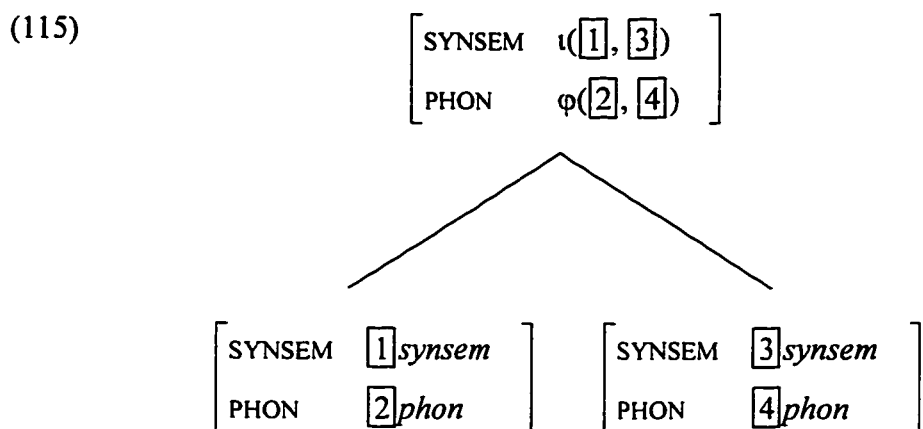

In the usual, syntagmatic, interpretation of sign-based theories, this structure is interpreted as the internal part-whole structure of a sign. The sign represented by a constituent structure includes the mother node and its daughters, which are themselves signs. Thus, the sign represented by the constituent structure contains smaller signs as part of its structure. In terms of licensing, we can describe the situation as follows:

$$(116) \text{ Sign 1: } \begin{bmatrix} \text{SYNSEM} & \boxed{1} \textit{synsem} \\ \text{PHON} & \boxed{2} \textit{phon} \end{bmatrix}$$

$$\text{Sign 2: } \begin{bmatrix} \text{SYNSEM} & \boxed{3} \textit{synsem} \\ \text{PHON} & \boxed{4} \textit{phon} \end{bmatrix}$$

$$\text{Sign 3: } \begin{bmatrix} \text{SYNSEM} & \iota(\boxed{1}, \boxed{3}) \\ \text{PHON} & \varphi(\boxed{2}, \boxed{4}) \end{bmatrix}$$

Licensing statement: sign 3 is wellformed iff sign 1 and sign 2 are wellformed.

This interpretation of sign-based linguistics uses a concept of “sign” that is somewhat more complicated than the usual Saussurean sense. Root morphemes (that is, morphologically simple forms) are simple Saussurean signs—they consist of semantic and phonological information. Morphologically (or syntactically) complex forms also contain semantic and phonological information. But, in addition, they also contain information about their daughters. That is, these signs contain other signs within them.

The paradigmatic interpretation of sign-based linguistics is based strictly on the Saussurean sense of the term “sign”. In this interpretation, each node in a constituent structure is a sign. Constituent structures are taken to be licensing statements for the sign

represented by the top node. For example, the licensing statement for the structure in (115) is as follows:

$$(117) \quad \text{Sign 1:} \quad \left[\begin{array}{l} \text{SYNSEM} \quad \boxed{1} \textit{synsem} \\ \text{PHON} \quad \boxed{2} \textit{phon} \end{array} \right]$$

$$\text{Sign 2:} \quad \left[\begin{array}{l} \text{SYNSEM} \quad \boxed{3} \textit{synsem} \\ \text{PHON} \quad \boxed{4} \textit{phon} \end{array} \right]$$

$$\text{Sign 3:} \quad \left[\begin{array}{l} \text{SYNSEM} \quad \iota(\boxed{1}, \boxed{3}) \\ \text{PHON} \quad \varphi(\boxed{2}, \boxed{4}) \end{array} \right]$$

Licensing statement: sign 3 is wellformed iff sign 1 and sign 2 are wellformed.

More concisely, we can use a function notation:

$$(118) \quad \text{sign}_3 = f(\text{sign}_1, \text{sign}_2)$$

This notation suggests intuitively that sign 3 is derived, in some sense, from sign 1 and sign 2 (although such directionality is not a formally inherent property of functions). This interpretation is quite similar to the item-and-process interpretation of Sign-Based Morphology, discussed in section 3.2.2. However, the item-and-process view need not be viewed as inherently derivational. With this in mind, it is in fact quite similar to the word-and-paradigm view of morphology (as noted by Anderson 1992). To make this more intuitive, we may express the constituent structure licensing statement in terms of a relation:

(119) sign 3 is wellformed iff:

i) sign 1 and sign 2 exist

ii) there is a relation \mathfrak{R} in the grammar such that $\mathfrak{R}(\text{sign}_1, \text{sign}_2, \text{sign}_3)$

This interpretation of Sign-Based Morphology is quite similar to the loosely paradigmatic approach discussed in section 3.5.2. The main difference is that the Sign-Based Morphology does not make the stipulation that all signs must be independent words. As there are demonstrable cases of morphological constituents that are not themselves words (sections 3.5.6.1, 5.6), Sign-Based Morphology has the empirical edge in this respect. Other differences between the approaches are discussed in section 3.5.6.

In view of the fact that Sign-Based Morphology is quite similar in spirit to realizational approaches to morphology, it is hardly surprising that it also has a plausible paradigmatic interpretation, since paradigmatic morphology and realizational morphology are intimately connected to each other. It is perhaps more surprising that Sign-Based Morphology is also able to incorporate insights from constituent structure-based views.

3.5.5 Comparison of Sign-Based Morphology with strictly paradigmatic approaches

Although Sign-Based Morphology has a reasonable paradigmatic interpretation, it is quite different in spirit from strictly paradigmatic approaches to morphology such as that of Bochner (1993). Strictly paradigmatic approaches to morphology relate all words that share any given morphological property. For example, all words that share a root

morpheme form a paradigm. Similarly, all words that contain the same plural suffix (for example), form a paradigm. Sign-Based Morphology, by contrast, relates stems (not necessarily words) to each other only if there is a grammatical construction explicitly licensing such a relation. For example, in Sign-Based Morphology, the English words *book* and *books* are related to each other by grammatical constraints because there is a pluralization construction that explicitly states that a singular noun may be related to its plural version by the addition of the plural suffix (and the accompanying morphophonemic correspondences). The words *books* and *cats* are not related by grammatical constraints, because there is no grammatical construction that licenses such a relation.

The construction orientation of Sign-Based Morphology is crucial for capturing cyclic phonological effects. The main challenge is determining which forms stand in a correspondence relation for the purposes of phonology. In Sign-Based Morphology, this challenge is addressed by using constructions. Forms stand in correspondence if and only if there is a construction that explicitly allows them to be combined. For example, recall from section 2.1 that suffixed forms must be disyllabic for certain speakers of Istanbul Turkish (120):

- (120) a) do: 'musical note C'
b) *do:-m 'C-1sg.poss'

The form **do:-m* remains ungrammatical even when we add a further suffix to it such that the total size is two syllables:

- (121) a) *do:-m 'C-1sg.poss'
 b) *do:-m-u 'C-1sg.poss-acc'

We may conclude therefore that the possessed form in (120b) and the possessed accusative form in (121b) stand in correspondence. This correspondence is licensed by a construction in Sign-Based Morphology (122):

(122) Accusative construction

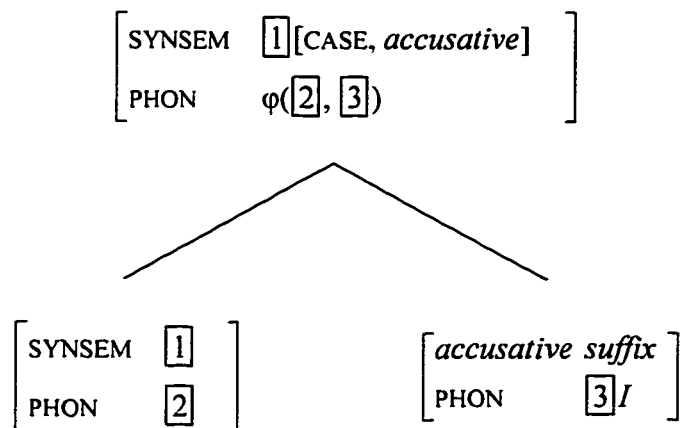

In the strictly paradigmatic approach, the forms stand in correspondence, because any forms that share morphemes stand in correspondence. It is sufficient that these forms share the same root.

The noun in (120a) can be pluralized in Turkish. The result is grammatical: the plural suffix adds a syllable; the output therefore contains two syllables and satisfies the disyllabic minimal size requirement (124a). When the first person singular possessive suffix is added to this plural form, the resulting noun is still grammatical.

- (123) a) do:-lar 'C-pl'
 b) do:-lar-um 'C-pl-1sg.poss'

From this, we may conclude that plural possessed nouns do not interact phonologically with singular possessed nouns. Otherwise we would expect the form in (124b) to be ungrammatical (we know from (121) that forms that stand in correspondence with **do:-m* 'C-1sg.poss' are ungrammatical).

- (124) Turkish forms that don't interact:
 a) *do:-m 'my C'
 b) do:-lar-um 'C-pl-1sg.poss'

In Sign-Based Morphology, this result is not surprising. There is no grammatical construction that relates possessed singular nouns to possessed plural nouns. There is therefore no need to expect the nouns in (124) to stand in a grammatical correspondence relation.

The situation is more complicated in the strongly paradigmatic approach: *do:-lar-um* contains all the morphemes in **do:-m*, plus an additional (plural) morpheme. We would therefore expect them to stand in correspondence.

Since the strongly paradigmatic approach allows all forms that share any morphological property to stand in grammatical correspondence, it is unable to deal with cyclic effects. Cyclic phonological effects need to make crucial reference to the morphological structure of a form in terms of dominance relations. By rejecting the

existence of such structure, the strongly paradigmatic approach makes it impossible to deal with cyclic effects. Bochner (1993) acknowledges this point in his section 5.5, and claims that cyclic effects in fact do not exist. His main claim is that apparent cyclic effects are always restricted to cases of unproductive morphology, which, he remarks, may be considered a historical relic. Bochner argues that the proper treatment of such cases is by suppletive allomorphy, and an analysis in terms of a single underlying form is not called for:

(125) "... my claim is that all cases [of apparent cyclic phonology] can be treated this way [as suppletion], and that there is no need for cyclic application of phonological rules within the word." (Bochner 1993: 202)

Most of the examples used in this work have to do with freely productive and regular morphology. It therefore appears that strictly paradigmatic approaches do not provide a satisfactory way to deal with the phonology-morphology interface.

One area in which the strictly paradigmatic approach seems to have an empirical advantage is Bracketing Paradoxes (Pesetsky 1985, Spencer 1988, Cohn 1989, Sadock 1991, Becker 1993). Bracketing Paradoxes have not yet been studied in any detail within Sign-Based Morphology. The paradigmatic approach can deal with these by using a paradigm consisting of multiple related words, as discussed by Becker (1993). For example, the following paradigm can be set up to deal with the famous type of Bracketing Paradox exemplified by the English word *ungrammaticality*:

(126) $\left\{ \begin{array}{l} \left[\begin{array}{l} /X/ \\ \text{Adj} \\ A \end{array} \right], \left[\begin{array}{l} /unX/ \\ \text{Adj} \\ \text{not } A \end{array} \right], \left[\begin{array}{l} /Xity/ \\ N \\ \text{state of being } A \end{array} \right], \left[\begin{array}{l} /unXity/ \\ N \\ \text{state of being not } A \end{array} \right] \end{array} \right\}$

This paradigmatic statement captures the insight expressed by Kiparsky (1983) that Bracketing Paradoxes of this type are blends of some sort: a word of the structure *un-X-ity* exists just in case *un-X* and *X-ity* exist.

In conclusion, the paradigmatic approach seems to have an advantage in that it can deal successfully with Bracketing Paradoxes. The status of these in Sign-Based Morphology is not clear at this point. One point that may be interesting to notice is that in any given example of Bracketing Paradoxes, only one structure is ever phonologically relevant. For example, for the purposes of phonology, only the structure *un + grammaticality* is relevant. The other structure is relevant only for semantic purposes. We do not find cases where a given word has two different structures motivated such that the phonology needs to make reference to both structures. If this observation is correct, then the right approach to Bracketing Paradoxes may be to use parallel phonological and morphological structures, along the lines of Cohn 1989, Inkelas 1989, and especially Sadock 1991. This possibility has been discussed from an Sign-Based Morphology perspective in Orgun 1994c, Orgun 1995b. More research is needed before any definitive conclusions can be drawn in this area.

Although the strictly paradigmatic approach is in a good position to deal with Bracketing Paradoxes, it does not offer a satisfactory theory of the phonology-morphology interface in that it has no way at all of dealing with cyclic effects. A successful theory of cyclic phonological effects needs to make crucial reference to morphological structure in order to determine which words stand in grammatical

correspondence. In Sign-Based Morphology, constructions determine what forms are related. The basis of the strictly paradigmatic approach is its the rejection of constituent structures and constructions. From the perspective of this work's focus on the phonology-morphology interface, the Sign-Based Morphology is clearly preferable to the strictly paradigmatic approach, although Bracketing Paradoxes still remain to be investigated.

3.5.6 Comparison of Sign-Based Morphology with loosely paradigmatic approaches and syntagmatic approaches with transderivational identity

At first sight, the loosely paradigmatic approach of Burzio (1994) appears to be fundamentally different from Sign-Based Morphology. I have already shown in section 3.5.4 that Sign-Based Morphology is conceptually quite compatible with a paradigmatic understanding of morphology. In this section, I demonstrate that the loosely paradigmatic approach is the closest one in spirit to Sign-Based Morphology of all paradigmatic approaches to morphology. In fact, once certain minor modifications to remedy some empirical deficiencies of the loosely paradigmatic approach are carried out, it becomes practically indistinguishable from the paradigmatic interpretation of Sign-Based Morphology.

3.5.6.1 Bound complex stems

The first and most obvious, if superficial, difference between Sign-Based Morphology and the loosely paradigmatic approach is that Sign-Based Morphology allows reference to morphologically complex stems that are not independent words, while the loosely paradigmatic approach does not accept the existence of such entities as bound stems. The

restriction of reference to independent words is a choice in the loosely paradigmatic approach. This choice can be abandoned at no cost to the theory if empirical evidence requires reference to bound complex stems. Two phenomena that fit this bill have been discussed in the Sign-Based Morphology literature. The first is Cibemba verb stems (Orgun 1995a), discussed in full detail in section 5.6 of this work. The second is Sami passive forms (Dolbey 1996, Dolbey and Orgun 1996). I summarize the main aspects of Sami passive forms here.

The phenomenon of interest is apparent syllable-counting allomorphy in Sami. Essentially, a number of suffixes have two allomorphs such that the first allomorph attaches to bases that contain an even number of syllables, and the second allomorph to bases containing an odd number of syllables (Dolbey 1996). In (127), syllable boundaries are indicated by periods:

(127)	<u>affix</u>	<u>Even-syllable stem</u>	<u>Odd-syllable stem</u>
		jear.ra ‘ask’	veah.ke.heh ‘help’
	1du	je:r.re-∅	veah.ke.he:-t.ne
	2du	jear.ra-beht.ti	veah.ke.heh-hp.pi
	2pl	jear.ra-beh.tet	veah.ke.he:-h.pet
	3pl.pret	je:r.re-∅	veah.ke.he:-d.je

For clarity, the even- and odd-number allomorphs of these suffixes are listed in (128):

(128)	<u>affix</u>	<u>Even-syllable stem</u>	<u>Odd-syllable stem</u>
	1du	-∅	-tne
	2du	-beht.ti	-hppi
	2pl	-behtet	-hpet
	3pl.pret	-∅	-dje

Notice that the allomorphs that attach to even-numbered stems themselves contain an even number of syllables. Conversely, the allomorph that attach to odd-numbered stems contain an odd number of syllables. As Dolbey observes, this suggests that the allomorphs are chosen based on the foot pattern of the output. Specifically, the allomorph that allows the output to be exhaustively parsed into binary feet is chosen. Following Kager 1995, Dolbey uses output optimization to account for this allomorphy. The candidate output set includes candidates bearing each allomorph of the appropriate suffix. As usual, the candidate that fares best with respect to the constraint system is the grammatical output. EVAL in this case ends up selecting not just the morphophonemically optimal output, but also the one with the desired allomorph. This is illustrated in the tableaux in (129), taken from Dolbey 1996. The constraint *STRAY- σ rules out syllables not incorporated into binary feet. (feet are enclosed in parentheses in candidate output forms):

(129)

	/jearra, {beahhti ~ hppi}/	*STRAY- σ
σ	(jear.ra)(beah.ti)	
	(jear.rahp)pi	*!

	/veahkehea, {beahhti ~ hppi}/	*STRAY- σ
σ	(veah.ke)(hea-hp.pi)	
	(veah.ke)(hea.-beah)t	*!

As Dolbey shows, the passive affix displays a pattern of allomorphy similar to that found in the person/number affixes shown earlier: a two-syllable allomorph attaches to stems

containing an even number of syllables, while a one-syllable allomorph attaches to stems containing an odd number of syllables (130):

(130)		<u>Even-syllable stem</u>	<u>Odd-syllable stem</u>
	Stem	jear.ra ‘ask’	veah.ke.heh ‘help’
	Passive	jer.ro-juv.vo	veah.ke.hu-v.vo

The allomorphs of the passive suffix are shown in (131):

(131)		<u>Even-syllable stem</u>	<u>Odd-syllable stem</u>
	Stem	-juvvo	-vvo

The following tableau shows how the correct form *jer:ro-juvvo* is derived by output optimization (132):

(132)		/jearra, {juvvo ~ vvo}/	*STRAY-σ
	☞	(jer.ro)(juv.vo)	
		(jear.ruv)vo	*!

The passive forms in (130) do not occur as independent words. They must be inflected for person and number. Since the person and number affixes (just like the passive affix) have syllable-counting allomorphy, there would appear to be two choices for the ultimate output. In the case of a stem with an even number of syllables, there are two ways in which an exhaustively footed word can be formed: we could choose the monosyllabic allomorph of both suffixes, or the disyllabic allomorph of both suffixes. As Dolbey points out, only the second option is grammatical (133):

- (133) *(je:r.ru)-(v.vo-hp.pi) 'ask-pass-2du'
 (je:r.ru)-(juv.vo)-(beht.ti) 'ask-pass-2du'

For a stem with an odd number of syllables, an exhaustively footed word could be created by selecting the monosyllabic allomorph of one suffix and the disyllabic allomorph of the other. It turns out that the monosyllabic allomorph of the passive suffix and the disyllabic allomorph of the person/number suffix must be chosen. It is not possible to use the disyllabic allomorph of the passive suffix and the monosyllabic allomorph of the person/number suffix (134):

- (134) (veah.ke)(hu-v.vo)-(beht.ti) 'help-pass-2du'
 *(veah.ke)(hea.-juv)(vo-hp.pi) 'help-pass-2du'

According to Dolbey's analysis, the passive stem in Sami is subject to exhaustive footing on its own, as shown in (130). Grammatical and ungrammatical passive stems are shown in (135):

- (135) (veah.ke)(hu-v.vo) 'help-pass'
 *(veah.ke)(hea-juv)vo 'help-pass'
 (je:r.ru)-(juv.vo) 'ask-pass'
 *(je:r.ru)-v.vo 'ask-pass'

It is to the grammatical stems in (135) that the person/number affixes must be added. Since the grammatical stems necessarily contain an even number of syllables (because they are subject to optimization in this regard), it follows that they will always combine with the disyllabic allomorphs of the person/number suffixes. Thus, a satisfactory

analysis of Sami morphology must be based on correspondence constraints between passive stems and words. Since the passive stems cannot occur as words on their own, but must take obligatory person/number affixes, the claim that all correspondence constraints must hold between independent words is falsified, as observed by Dolbey and Orgun (1996).

The claim in the loosely paradigmatic approach that all correspondence constraints hold between words is identical to the claim by Aronoff 1976 that all morphology is word-based. Aronoff himself has since abandoned this claim, replacing it with the weaker but empirically more adequate claim that morphology is stem-based (Aronoff 1994; also Anderson 1992). The Sign-Based Morphology position is equivalent to stem-based morphology. The demonstration in this section shows that the loosely paradigmatic approach has to abandon word-based morphology in favor of stem-based morphology as well.

(136) Stem-based morphology: Correspondence constraints hold between stems (lexical entries) which may or may not be independent words.

Another compelling case of constraints holding on a morphologically bound stem is found in Cibemba (Hyman 1994). This case is discussed in detail in section 5.6.

Abandoning the stipulation that all correspondence constraints hold between words solves another problem that the loosely paradigmatic approach faces. This problem has to do with stems that seem to have the same morphological structure as independent words (that is, they contain the same morpheme), but are nonetheless not subject to some

phonological constraints that words are subject to. A good example of this phenomenon is found in Lardil, where word-final vowels and non-coronal consonants are deleted (Hale 1973).

(137)	<u>absolute</u>	<u>inflected</u>	<u>gloss</u>
	ŋalu	ŋaluk-in	'story'
	t ^h urara	t ^h uraraŋ-in	'shark'
	pirŋen	pirŋen-in	'woman'
	majar	majar-in	'rainbow'
	jarput	jarput-in	'snake'
	waŋal	waŋal-in	'boomerang'
	jalul	jalulu-n	'flame'
	majar	majara-n	'rainbow'
	jilijil	jilijil-in	'oyster'
	wiwal	wiwala-n	'mango'
	karikar	karikar-in	'butter fish'
	jukar	jukarpa-n	'husband'
	karawakar	karawakarwa-n	'wattle'
	putu	putuka-n	'short'
	murkuni	murkunima-n	'nullah'
	tipiti	tipitip-in	'rock cod'
	turara	turaraŋ-in	'shark'

The loosely paradigmatic approach does not face any particular difficulties in deriving the absolute form of words in Lardil. Since monomorphemic words are derived from their underlying form, the derivation is identical to a traditional generative one:

(138)	UR	murkunima
		↓
	Surface	murkuni

The word-basedness hypothesis makes it impossible to derive the inflected form, however. According to the hypothesis, the inflected form must be derived from the independent surface absolute form by the addition of the affix *-in*. It is therefore impossible to recover the lost underlying root final segments (139):

(139) Word₁: murkuni
 Word₂ = [Word₁ + affix]: murkuni + in
 Predicted surface form: *murkunin

Abandoning the word-based hypothesis allows the loosely paradigmatic approach to offer an analysis of these Lardil forms: the absolute stem is identical to the underlying root. The inflected stem is formed by adding the suffix *-in* to the underlying root. The absolute stem and the inflected stem may both undergo a word construction (140):

(140)	<u>Absolute form</u>		<u>Inflected form</u>
	UR:	murkunima	UR: murkunima
	Word:	murkuni	Inflected stem: murkuniman
			Word: murkuniman

Thus, even when a particular combination of morphemes may stand alone as an independent word, stem-based rather than word-based morphology may be called for. Thus, the word-based representation of paradigmatic relations that Burzio proposes (111) should be replaced by the stem-based interpretation in (141):

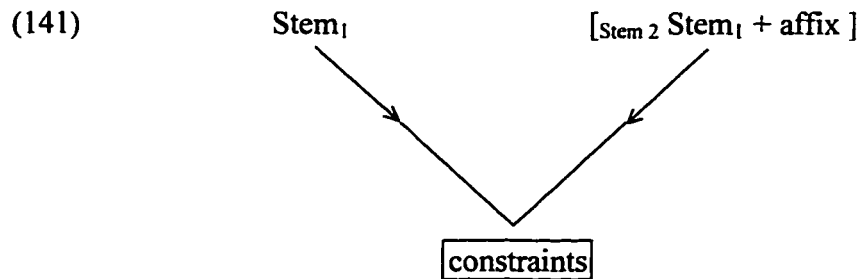

In addition to (141), we also need constructions for compounding, nonconcatenative morphology, and a word construction that forms words from (some but not necessarily all) stems.

3.5.6.2 Noncyclic effects

Another aspect in which Sign-Based Morphology differs from the loosely paradigmatic approach is its construction orientation. The depiction of the loosely paradigmatic approach in (141) implies that correspondence constraints hold between any pair of stems that differ by one morpheme. This interpretation is unable to deal with noncyclic phonological effects, however. Consider, for example, subminimal verbal forms in Turkish (section 2.1), which can be repaired by adding tense/aspect suffixes (142):

(142) <u>Form</u>	<u>Gloss</u>	<u>Comments</u>
je	'eat'	Roots not subject to disyllabic minimality
*je-n	'eat-pass'	Subminimal suffixed form
je-n-ir	'eat-pass-imprf'	Total size is two syllables

According to the system in (141), the passive imperfective form must stand in correspondence with the passive form, not with the root. This, however, incorrectly predicts the passive imperfective form to be ungrammatical. The problem here is that the

paradigmatic correspondence is assumed to be automatic in the loosely paradigmatic approach: whenever two stems exist that differ in only one morpheme, they stand in correspondence. In Sign-Based Morphology, on the other hand, the correspondence relation is construction-oriented. Two stems stand in correspondence if and only if there is a grammatical construction that explicitly allows such a correspondence relation. This property of Sign-Based Morphology has two desirable consequences. First, it eliminates unwanted correspondences. In Turkish, for example, passive forms are prevented from standing in correspondence with passive imperative forms by not including a construction in the grammar that sanctions such a correspondence. Second, stems that differ by more than one morpheme may be allowed to stand in correspondence by including grammatical constructions that sanction such a situation. For example, in Turkish, bare roots can stand in correspondence with passive imperfective forms, thanks to a grammatical construction that sanctions this (143):

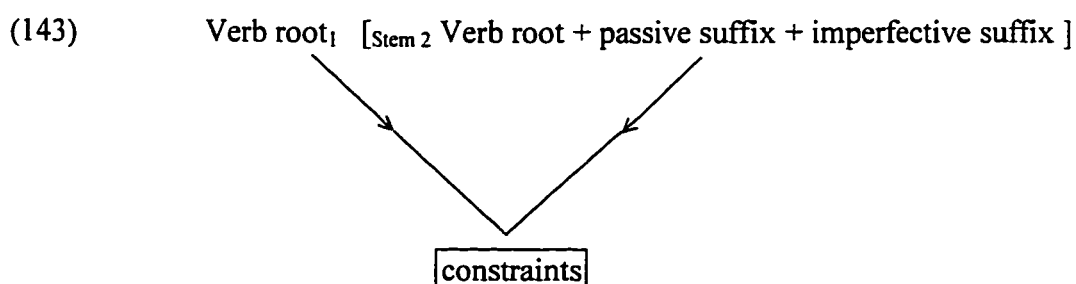

Thus, paradigmatic correspondences should not be defined automatically from linear strings of morphemes, but rather should be explicitly sanctioned by grammatical constructions.

3.5.6.3 Inside-out effects

As mentioned earlier, one of the fundamental properties of cyclic phonological effects is their inside-out nature. That is, in synchronic morphology it is always morphologically simpler forms that exert a phonological influence on more complex forms, never vice versa. This contrasts with paradigmatic effects in diachronic change, which may very well be outside-in. Since the loosely paradigmatic approach assumes the correspondence relation to be symmetric, how does it account for the inside-out nature of cyclic effects? In this section, I discuss the status of these effects in the loosely paradigmatic approach as well as the syntagmatic approach enriched with transderivational identity. The Italian example I use comes from Kenstowicz's (1995) work, which assumes the syntagmatic approach enriched with transderivational identity. However, the discussion applies to the loosely paradigmatic approach as well: the only difference between the two approaches is that the syntagmatic approach allows reference to the full underlying string for each word in addition to allowing correspondence constraints between words, whereas the paradigmatic approach lacks the former mechanism. This additional mechanism is not crucially used in Kenstowicz's analysis of Italian.³³ The demonstration below is therefore equally valid for the loosely paradigmatic approach, which possesses all and only the mechanisms used in the analysis.

I first illustrate the syntagmatic approach enriched with transderivational identity in more detail by summarizing Kenstowicz's (1995) Optimality Theoretic analysis of Northern Italian s-voicing, based on data discussed by Nespors and Vogel (1986). In the

relevant dialects, [s] and [z] are in complementary distribution, with [z] appearing intervocalically:³⁴

(144)	azola	‘button hole’
	azilo	‘nursery school’
	kaz-a	‘house’
	kaz-ina	‘house-dim’

As noted by Nespors and Vogel, s-voicing does not apply consistently across morpheme boundaries. The rule applies in (145a,c), but not in (145b):

(145)	a)	diz-onesto	‘dishonest’
		diz-uguale	‘unequal’
	b)	a-sotfale	‘asocial’
		bi-sessuale	‘bisexual’
		ri-suonare	‘to ring again’
		pre-sentire	‘to hear in advance’
	c)	re-zistentsa	‘resistance’
		pre-zentire	‘to have a presentiment’

Kenstowicz claims, following Nespors and Vogel, that the failure of s-voicing to apply in (145b) is connected to the fact that the stem is an independent word in these forms. The contrast between *rezistentsa* and *asotfale* is to be explained by the fact that the stem is

³³ Nor has this additional tool been used in any analysis in the literature. It is therefore not clear that this excess power is justified.

³⁴ The Italian data, like all data in this work, are presented in IPA. Thus, [s] is a voiceless alveolar fricative and [z], its voiced counterpart.

an independent word in the latter but not in the former.³⁵ In the paradigmatic approach, this idea is implemented by invoking correspondence constraints between related words. Thus, identity constraints are enforced between *sotfale* and *asotfale*. By ranking the identity constraints higher than the phonotactic constraint responsible for s-voicing, the failure of voicing to apply to *asotfale* can be accounted for. Kenstowicz formulates his analysis of Italian s-voicing in terms of Optimality Theory (Prince and Smolensky 1993). The tableau in (146) shows how the correct surface form [azola] is derived from the input form /asola/. This tableau establishes a crucial constraint ranking, namely that faithfulness to input (FAITH) is outranked by the phonotactic constraint responsible for s-voicing (VzV)—otherwise, the predicted output for the given input would be *[asola].

(146)

/asola/	VzV	FAITH
[asola]	*!	
☞ [azola]		*

Having established the crucial constraint ranking VzV»FAITH, I now return to the alleged paradigm uniformity effect responsible for the failure of s-voicing to apply in [asotfale].

The diagram in (147) illustrates the usual input-output relation and the novel paradigm uniformity relation at work:

³⁵ This difference between bound and free morphs was noted by Kiparsky 1982, who proposed to account for it by assuming that free morphs undergo a root cycle while bound morphs do not (see also Inkelas 1990). Kiparsky's approach (although stipulative) has greater empirical success than the paradigmatic approach. This is because morphologically complex stems are *always* cyclic domains, even when they are not possible words. See Orgun 1994c, 1995a for discussion of this issue from a Sign-Based Morphology perspective.

Output-output identity prevents s-voicing to apply to the morphologically derived form [asotʃale]. In the case of *dizonesto*, *dis* is not an independent word. Therefore, no paradigmatic correspondence constraints apply. There is nothing to block s-voicing.³⁶

Unfortunately, the constraint system in its present form predicts the pair *[zotʃale], *[azotʃale] to be the winner. This is illustrated in (149):

(149)

/sotʃale/, /a-sotʃale/	O-O IDENT	VzV	FAITH
[sotʃale], [azotʃale]	*!		*
(☞) [sotʃale], [asotʃale]		*!	
☛ [zotʃale], [azotʃale]			**

It is not a trivial matter to undo this unfortunate prediction. Kenstowicz proposes a principle of “base identity” to deal with this issue. This principle amounts to stipulation to the effect that the “base” (morphological input) form is not altered in response to output-output identity constraints. Benua 1996 takes a more indirect, ingenious route. According to her proposal, two copies of the constraint system are in effect in an evaluation of a morphologically related pair. One copy is enforced on the base, and the other copy is enforced on the derived form. Benua stipulates that all the constraints that apply to the base outrank all the constraints that apply to the derived form. It follows that the base will never be influenced by the derived form, but the derived form may be influenced by the

³⁶ This account cannot, however, handle the contrast between [presentire] and [prezentire], which both (presumably) involve the same stem [sentire], which occurs independently as a word on its own. In Lexical Phonology terms, this contrast is accounted by invoking a pre-affixal stem cycle in one case but not the other. See Inkelas 1990 for details of this idea. In Sign-Based Morphology, this can be handled

base. I will not dwell on the details of these proposals here, except to note that they are both unmotivated stipulations that do not follow in any way from any aspect of the theory. They are designed simply to mimic the effects of a cyclic derivation. To make matters worse, both approaches have global power, allowing full reference to the underlying forms of the morphemes involved as well as the surface form of the base. By contrast, the inside-out nature of interleaving effects, which Benua and Kenstowicz's stipulations are designed to encode, follows as a direct consequence of the basic architecture of Sign-Based Morphology, where the derived form cannot have an effect on the base simply because it is not part of the constituent structure representation of the base. I illustrate this by presenting sign-based representations of the crucial Italian forms. The derived form [a-sot{ale}] has the constituent structure in (150):

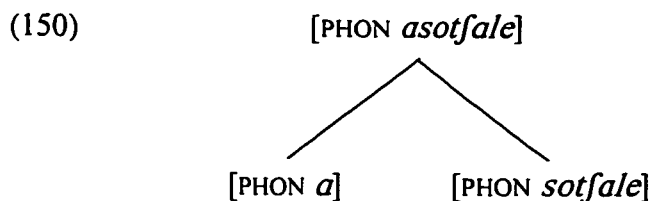

As in Kenstowicz's account, identity to the "base" (that is, the daughter node *sotfale*) must outrank the phonotactic constraint VzV. Obviously, the base may have a phonological effect on the derived form, since the base is a subconstituent of the derived form. There is no need to stipulate the existence of identity constraints holding between morphologically related forms. Relatedness is already encoded by the constituent

by enforcing phonological constraints on the daughter node of constructions. See Stump 1995 and Orgun 1995d for discussion of this possibility.

structure, as in almost all linguistic theories. The constituent structure of the “base” form *sotfale* is shown in (151):

(151) [PHON *sotfale*]

Obviously, there is no way that the derived form could exert any phonological influence on the base form. The derived form is not part of the morphological representation of the base form. This is a direct consequence of using constituent structures, which even authors like Benua, Kenstowicz, and McCarthy seem to implicitly assume. To recapitulate, the inside-out nature of interleaving effects is an integral part of Sign-Based Morphology. The phonology-morphology interface could not have been any other way given the framework. In the paradigmatic approach, this most basic property (which has also formed the basis of the framework of Lexical Phonology) is handled by an awkward stipulation.

We have seen how the inside-out nature of cyclic effects follows from the syntagmatic interpretation of Sign-Based Morphology. Since the goal of this section is to explore the connection between Sign-Based Morphology and paradigmatic approaches to morphology, I turn to the status of inside-out effects from the perspective of the paradigmatic interpretation of Sign-Based Morphology. The paradigmatic interpretation of Sign-Based Morphology is based on licensing statements of the sort in (152):

(152) Unary construction (e.g., affixation, zero derivation, etc.):

- Sign₂ is wellformed iff: i) Sign₁ is wellformed, and
- ii) The grammar contains a relation \mathfrak{R} such that $\mathfrak{R}(\text{Sign}_1, \text{Sign}_2)$

Binary construction (e.g., compounding)

- Sign₃ is wellformed iff: i) Sign₁ and Sign₂ are wellformed, and
- ii) The grammar contains a relation \mathfrak{R} such that $\mathfrak{R}(\text{Sign}_1, \text{Sign}_2, \text{Sign}_3)$

etc.

The inside-out nature of interleaving effects follows as a direct consequence of such licensing statements. To make this point explicit, let us consider the Turkish disyllabic minimal size condition, which provides a rather striking illustration of the need to restrict cyclic phonological effects to be inside-out. For nominal forms in Turkish, the situation is summarized in (153):

(153)	<u>Form</u>	<u>Gloss</u>	<u>Comments</u>
	do:	‘note C’	Disyllabic minimality not enforced on roots
	*do:-m	‘C-1sg.poss’	Subminimal form
	*do:-m-u	‘C-1sg.poss-acc’	Supraminimal, but ungrammatical because related form *do:-m is ungrammatical
	sol ⁱ	‘note G’	Disyllabic minimality not enforced on roots
	sol ⁱ -ym	‘G-1sg.poss’	Supraminimal, therefore grammatical
	sol ⁱ -ym-y	‘G-1sg.poss-acc’	Grammatical, because related form sol ⁱ -ym-y is grammatical

Let us first consider how *solⁱ-ym-y* ‘my G-acc’ is licensed. The licensing statement for this form is shown in (154), where the stem that this form is to be grammatically related to is (correctly) identified as *solⁱ-ym* ‘G-1sg.poss’:

(154) *solⁱ-ym-y* is wellformed if and only if:

- i) *solⁱ-ym* is wellformed, and
- ii) There is a grammatical relation \mathfrak{R} such that $\mathfrak{R}(solⁱ-ym, solⁱ-ym-y)$

Clause (ii) is satisfied, since there *is* a grammatical relation (namely the accusative construction) that has the desired property. We must check that clause (i) is also satisfied.

To do this, we must consider the licensing statement for the form *solⁱ-ym* (155):

(155) *solⁱ-ym* is wellformed if and only if:

- i) *sol^j* is wellformed, and
- ii) There is a grammatical relation \mathfrak{R} such that $\mathfrak{R}(sol^j, sol^i-ym)$

Clause (i) is satisfied, because *sol^j* is wellformed by virtue of being a lexical entry (an underlying form). Clause (ii) is also satisfied: the first person possessive construction is the desired relation.

Let us turn to the ungrammatical form **do:-m-u* ‘C-1sg.poss-acc’. The licensing statement for this form is shown in (156):

(156) *do:-m-u* is wellformed if and only if:

- i) *do:-m* is wellformed, and
- ii) There is a grammatical relation \mathfrak{R} such that $\mathfrak{R}(do:-m, do:-m-u)$

Clause (ii) is once again satisfied: the accusative construction is the relation we need. To check whether clause (i) is satisfied, we must consider the licensing statement for *do:-m* ‘C-1sg.poss’ (157):

(157) *do:-m* is wellformed if and only if:

- i) *do:* is wellformed, and
- ii) There is a grammatical relation \mathfrak{R} such that $\mathfrak{R}(do:, do:-m)$

Clause (i) is satisfied: *do:* ‘C’ is a lexical entry (underlying form). Clause (ii), however, is not satisfied: $\mathfrak{R}(do:, do:-m)$ does *not* hold, since the second argument is monosyllabic (suffixed forms must be disyllabic). Therefore, **do:-m-u* ‘C-1sg.poss-acc’ is ungrammatical. The bare form *do:* ‘C’ is licensed in the following manner: there is a lexical entry *do:*, and there is a relation (namely the word construction) such that $\mathfrak{R}(do:, do:)$.³⁷ It is clear that outside-in effects are not possible under this licensing interpretation of paradigmatic correspondence. The pitfall that the symmetric interpretation of paradigmatic correspondence is subject to is illustrated below:

³⁷ The word construction has not received much attention in this work, but the need for it is demonstrated quite clearly by the Lardil example discussed in the preceding section.

(158) i) Desired paradigmatic relation:

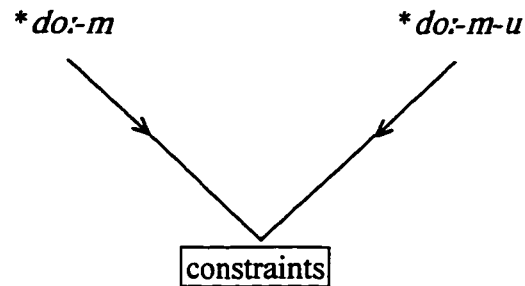

ii) Undesired paradigmatic relation:

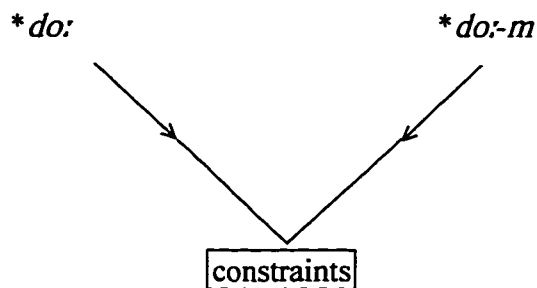

In (i), **do:-m-u* is ungrammatical because it stands in correspondence with **do:-m*. In (ii), *do:* is ungrammatical because it stands in correspondence with **do:-m*. If the paradigmatic relation is symmetric, there is no way to avoid this incorrect prediction. The licensing approach avoids this problem, as demonstrated above.

Thus, the paradigmatic approach needs to be based on licensing in order to deal with the inside-out nature of cyclic effects. There is no need for arbitrary and unmotivated stipulations like the primacy of the base or recursion of CON once a licensing-based approach is adopted. Since such an approach is required independently by the construction orientation (necessary to deal with noncyclic effects), the paradigmatic approach loses nothing by adopting it.

3.5.7 Level economy in the paradigmatic approach

Level Economy is the name given by Inkelas and Orgun (1995) to the principle that, contrary to the standard model in Lexical Phonology, forms only undergo phonology on those lexical levels where they undergo morphology. We will see in section 4.7.2 that level economy effects result in Sign-Based Morphology from the fact that phonological constraints are imposed on each node in a constituent structure. When a construct lacks a morpheme of a particular level, there is no node in the constituent structure that is subject to the phonological constraints of that level. This situation is, by definition, Level Economy. In the paradigmatic approach, level economy effects follow in more or less the same manner. Given a form like the Turkish *je-me* 'eat-neg.imper', correspondences would be set up between this form and the bare verb form *je* 'eat' (also a possible word, but incorrectly predicted to be ungrammatical by standard Lexical Phonology with level ordering, since every word goes through every stratum of the lexical phonology³⁸), in addition to the regular input output correspondences. This is shown in (159):

³⁸ Although Itô 1990 suggests that the immunity of underived forms from prosodic minimality might be due to the Strict Cycle Condition, Inkelas and Orgun 1995 show that this cannot be a general explanation, since nonderived roots in Turkish (and also in Latin, Mester 1995) *are* subject to another, bimoraic, minimal size condition.

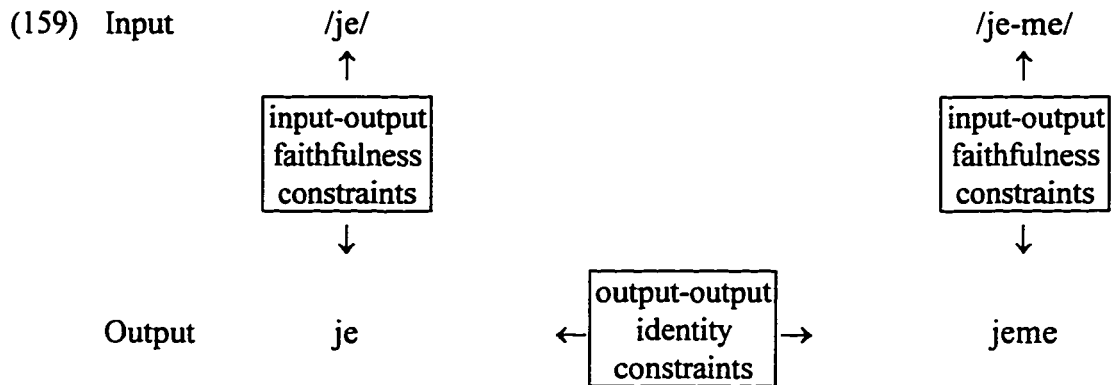

The input output constraints for *je* ‘eat’ do not include disyllabic minimality, a constraint that is not imposed on roots. Whether or not the constraints imposed on *je-me* ‘eat-neg.imper’ include disyllabic minimality, this form is going to be grammatical, since it contains the requisite number of syllables. There is no reason to expect the bare verb root *je* ‘eat’ to be (incorrectly) subject to level 1 constraints (those associated with the passive suffix), one of which, namely the minimal size constraint, it would violate. For comparison, the constraint layout for **je-n* ‘eat-passive’ is shown in (160):

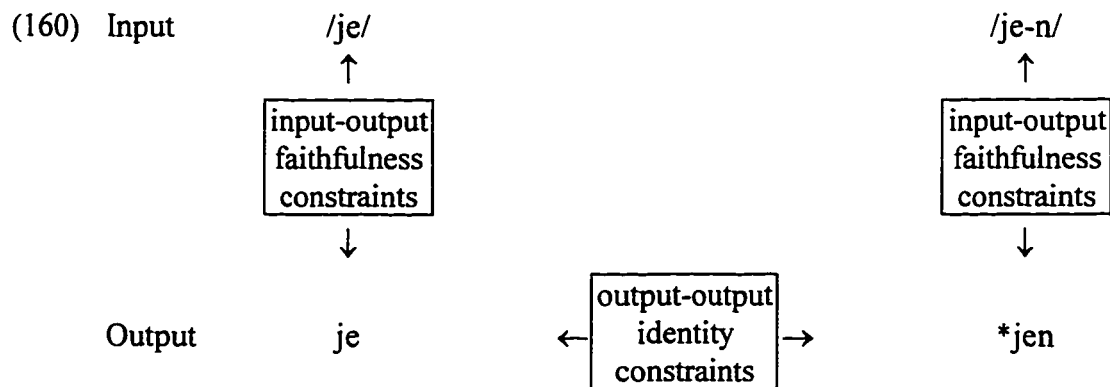

Here, the subminimal form **je-n* ‘eat-pass’ is ungrammatical because it violates the minimal size condition. I conclude therefore that the paradigmatic approach is just as successful as Sign-Based Morphology in handling Level Economy effects. Level Economy does not distinguish Sign-Based Morphology empirically from paradigmatic approaches to morphology.

3.5.8 Noncyclic phonological effects in the syntagmatic approach with transderivational identity

In this section, I will examine the status of noncyclic phonological effects in the paradigmatic approach. But first, let us look at how the apparent cyclic enforcement of the Turkish disyllabic minimal size condition in nominal forms is handled. The basic data are presented in (161):

- (161) *si:* ‘musical note B’
 **si:-m* ‘B-1sg.poss’
 **si:-m-e* ‘B-1sg.poss-dat’

The ungrammaticality of the disyllabic form **si:-m-e* ‘B-1sg.poss-dat’ suggests that the minimal size condition is enforced cyclically, that is, that the morphological subconstituent **si:-m* must be subject to phonology on its own as a phonological domain excluding the case suffix *-e*. The correspondence relations are set up in (162) (I omit the bare root form *si:* ‘musical note B’ for conciseness; it is irrelevant to the issue at hand):

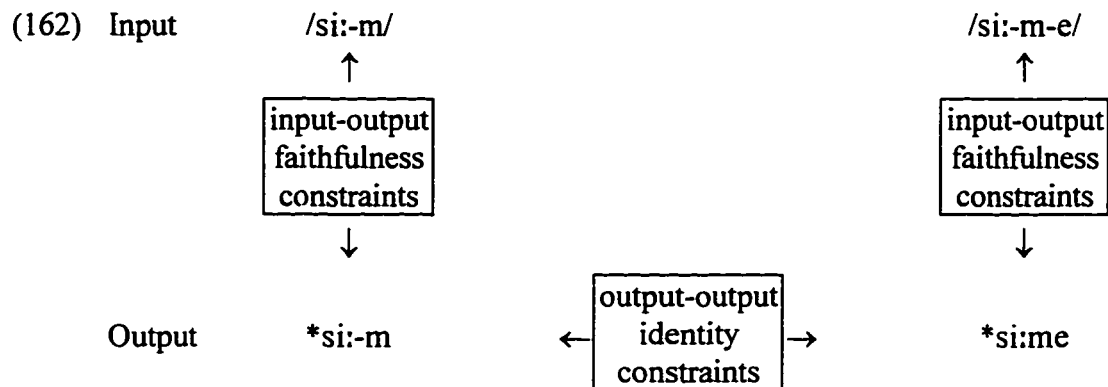

There are several difficulties in interpreting this diagram. First, recall that the proponents of the paradigmatic approach stipulate paradigm uniformity constraints to hold only between “surface” or “output” forms of existing lexical items. It is not clear in what sense there could be a “surface” form in the Turkish lexicon corresponding to the ungrammatical *si:-m* ‘B-1sg.poss’. A more natural position to take regarding ungrammaticality would be to say that there is no such lexical entry, rather than saying that there is such an entry listed in the Turkish lexicon, which comes with some sort of ungrammaticality tag that prevents it from being used. Even if the latter were allowed, it is not clear in what sense this item could be considered a surface form. It should be noted, however, that the restriction of paradigm uniformity constraints to surface forms only is a stipulation that in no way follows from any aspect of the theory. It can therefore be abandoned at no cost. In fact, Dolbey 1996, Dolbey and Orgun 1996 have argued that this stipulation must be abandoned in light of the cross-linguistically attested phenomenon of morphologically bound stems that act as cyclic phonological domains (Dolbey and Orgun’s examples come from Cibemba and Sami; the Cibemba example is discussed in section 5.6 of this study).

Even then, however, problems remain. Output-output constraints are generally, and doubtless rightly, understood to require the phonological shape of the morphologically derived form to be similar to the phonological shape of the “base”. In Italian, for example, base and derived form continuants are required to agree in voicing. Now, ungrammaticality is surely not a phonological feature alongside with voicing, metrical structure, and so on. How is it then that output-output identity constraints cause the derived form to inherit ungrammaticality from the base **si:-m* ‘B-1sg.poss’?

Even if treating ungrammaticality as a property that might be enforced by an output-output constraint to be shared between a base form and a derived form is allowed, problems still remain. The apparent noncyclic enforcement of the minimal size condition in verbal forms must still be handled. The basic data are repeated in (163):

(163)	<i>je</i>	‘eat’
	* <i>je-n</i>	‘eat-pass’
	<i>je-n-mif</i>	‘eat-pass-evid’

Whatever criterion is used by the paradigmatic approach to determine lexical relatedness (this is not made explicit by any of the authors whose work has been cited) must surely treat *je-n* ‘eat-pass’ and *je-n-mif* ‘eat-pass-evid’ as related. The relative configuration of this pair is identical to that of the nominal pair *si:-m* ‘B-1sg.poss’ and *si:-m-e* ‘B-1sg.poss-dat’. Since the latter count as related, so must the former.³⁹ We thus have the following pattern of correspondence constraints:

³⁹ Unless the criterion for relatedness is morphological subconstituency, as in Sign-Based Morphology. But in that case there is no need to stipulate paradigm uniformity

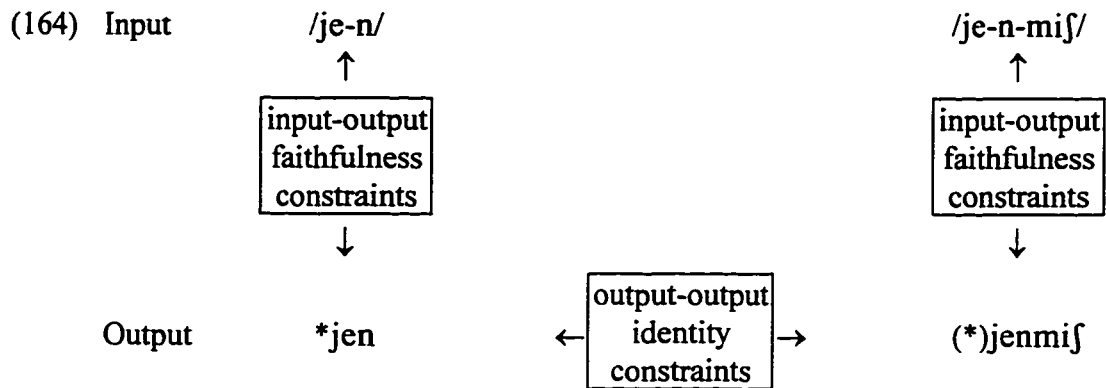

What is to prevent ungrammaticality to be inherited by the derived form in this case? The problem is that preventing ungrammaticality to be inherited is not the issue here. The two forms in (164) must not stand in any sort of correspondence relation at all. The paradigmatic approach seems to have no way of handling noncyclic phonological effects. The only solution seems to be to use different constraint rankings in different paradigms, a move that Benua 1996 explicitly rejects. This move would bring the paradigmatic approach even closer to Sign-Based Morphology: the need for constructions was already motivated in section 3.5.6.2. Allowing different constructions to be associated with different constraint rankings amounts to using cophonologies, a hallmark of Sign-Based Morphology.

This deficiency is not restricted to cases where ungrammaticality is involved. Straightforward phonological alternations pose the same problem, as I show by considering Ondarroa Basque vowel height assimilation. Recall that vowel height

constraints to begin with, as Sign-Based Morphology already handles all the relevant data by using no other tools than constituent structure.

assimilation applies crucially noncyclically in Ondarroa Basque. The relevant data are repeated in (165):

- (165) *mutiλ* 'boy'
mutiλ-e 'the boy'
mutiλ-a-k 'the boy-erg.' **mutiλ-e-k*

The fact that [a] raises to [e] at all means that the constraint responsible for height assimilation (which I will call SHARE [-low]) must outrank the competing input-output faithfulness constraint (FAITH [a]). This is shown in the tableau in (166):

(166)

/mutiλ-a/	SHARE [-low]	FAITH [a]
<i>mutiλa</i>	*!	
<i>mutiλe</i>		*

The correspondence relations between *mutiλ-e* 'the boy' and *mutiλ-a-k* 'the boy-erg.' are set up as shown in (167):

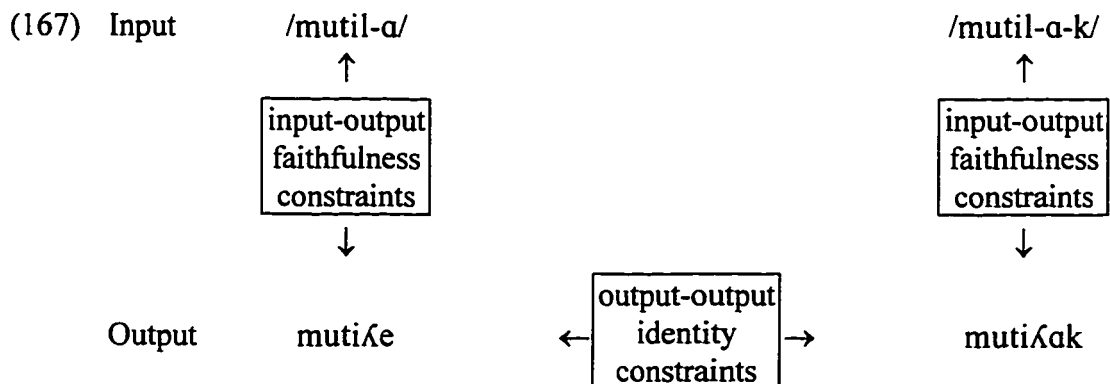

The fact that the definite article suffix vowel [a] in *mutiλ-a-k* ‘the boy-erg’ is faithful to its underlying form instead of copying the [e] in the base form *mutiλ-e* ‘the boy’ requires us to posit that faithfulness (FAITH [a]) is ranked higher than output-output identity (IDENT [a]). This is shown in the tableau in (168):

(168)

/mutiλ-a/, /mutiλ-a-k/	SHARE [-low]	FAITH [a]	IDENT [a]
[mutiλe], [mutiλek]		**!	
☞ [mutiλe], [mutiλak]		*	*
[mutiλa], [mutiλak]	*!		

Apparent noncyclic effects are handled by the paradigmatic approach in a way that differs greatly from the way they are handled in Sign-Based Morphology. In Sign-Based Morphology, flat structures give rise to noncyclic phonological effects. This means that there is no intermediate stem to refer to in noncyclic structures. In (168), *mutiλ-e* ‘the boy’ would have no part at all in the derivation of *mutiλ-a-k* ‘the boy-erg’. In the paradigmatic approach, the intermediate stem is still there, but cyclic effects are averted by utilizing the global power of the theory that allows reference to the underlying form of the morphemes involved, as well as to the surface form of the base. This approach thus predicts that cyclic and noncyclic phonological effects can coexist within a single derived form when more than one phonological alternation is involved. In the absence of positive evidence for this extra power, the more restrictive framework of Sign-Based Morphology, which does not allow cyclic and noncyclic phonological effects to be found in a single form, must be preferred.

(169) Output-output correspondence

Predicts “process-specific cyclicity”, that is, a given form exhibiting cyclic phonological effects with respect to some alternations and noncyclic effects with respect to other alternations. Such effects are not attested.

Sign-Based Morphology

Disallows process-specific cyclicity. Cyclic effects follow from branching structures, and noncyclic effects, from flat structures. The two cannot coexist.

Cyclic and noncyclic effects *can*, however, coexist within one language. In fact, the very same alternation may be observed as applying cyclically in some forms and noncyclically in others. The Turkish minimal size condition is a case in point. Basque height assimilation is another. Recall now that vowel height assimilation in Ondarroa Basque may apply cyclically under the right morphological conditions. The relevant data are repeated in (170):

(170) a)	/buru-a-da/ /baso-a-da/	[burure] [basure]	‘it is the head’ ‘it is the forest’
b)	/lagun-a-da/ /mendi-a-da/	[layunera] [mendiŋera]	‘it is the friend’ ‘it is the mountain’

The data in (170a) do not pose any challenge to the paradigmatic approach. The correspondence relations are as shown in (171):

In this case, the constraint ranking we have already established incorrectly predicts the derived form to fail to undergo vowel height assimilation, yielding *[layunara] instead of the correct form [layunera]. This is shown in the tableau in (174):

(174)	/lagun-a/, /lagun-a-da/	SHARE [+low]	FAITH [a]	IDENT [a]
☛	[layune], [layunara]		*	*
☞	[layune], [layunera]		**!	
	[layuna], [layunara]	*!		

Comparison of (174) with (172) makes it clear that it is impossible for the paradigmatic approach to handle both the cyclic and the noncyclic cases. The relative configurations of the base and derived forms are identical in the two groups of data, as made more explicit in (175):

(175)	Root	Base form	Derived form
	/mutil/	/mutil-a/	/mutil-a-k/
	/lagun/	/lagun-a/	/lagun-a-da/

In both examples, the base form satisfies the environment for vowel height assimilation, and therefore undergoes it. The resulting [e] is copied to the derived form in one case, but not the other. Adjusting the relative ranking of faithfulness to input and output-output identity is clearly not the right approach. Instead, the morphological constituent structure must be referred to, as in Sign-Based Morphology. This solution is of course available within the paradigmatic approach as well, by shifting to a construction-oriented approach as suggested in section 3.5.6.2.

Assuming different constraint rankings for forms with suffixes and clitics is another possible solution. This solution is available in the syntagmatic approach, which has the full underlying form available, but not in the loosely paradigmatic approach, which can only refer to a related stem. The construction-oriented solution is preferable, since it uses fewer mechanisms. In particular, since there is no demonstrated need for the global power of referring to the underlying form of complex words, the more restrictive loosely paradigmatic approaches appears to be preferable.

3.5.9 Summary of the paradigmatic aspect of Sign-Based Morphology

I have classified paradigmatic approaches to morphology into three main categories: strictly paradigmatic approaches, loosely paradigmatic approaches, and syntagmatic approaches with transderivational identity. Of these, the strictly paradigmatic approach is unable in principle to deal with cyclic phonological effects (as admitted by Bochner 1993). The remaining two are quite similar to each other. They possess exactly the same set of mechanism, except that the syntagmatic approaches has the additional power of global reference to underlying forms. This additional tool amounts to abandoning Bracket Erasure (Pesetsky 1979, Kiparsky 1982). Since this global power does not seem to be empirically justified (note that this added flexibility has in fact not been *used* by Benua, Kenstowicz, or McCarthy), the loosely paradigmatic approach seems to be the theory of choice among paradigmatic approaches to morphology.

The loosely paradigmatic approach is quite similar to Sign-Based Morphology in spirit. As defined by Burzio (1994), it suffers from a number of empirical problems,

which can, however, be remedied quite easily, and in a principled manner, by incorporating insights from Sign-Based Morphology. These are summarized in below.

- Stem-based morphology: correspondence constraints relate lexical entries (stems), which may or may not be independent words.
- Construction orientation: Two stems stand in grammatical correspondence if and only if such correspondence is sanctioned explicitly by a grammatical construction.
- Licensing: Grammatical correspondence constraints are licensing statements. A stem (Stem_n) is licensed if:
 - a) It is an underlying form, or
 - b) $\text{Stem}_1, \text{Stem}_2, \dots, \text{Stem}_{n-1}$ are licensed, and there is a grammatical relation \mathfrak{R} such that $\mathfrak{R}(\text{Stem}_1, \text{Stem}_2, \dots, \text{Stem}_{n-1}, \text{Stem}_n)$ holds.

Stem-based morphology is required because morphologically bound stems must be referred to by grammatical constraints. Construction orientation is necessary to deal with noncyclic phonological effects. Licensing accounts for the inside-out nature of cyclic phonological effects. All these inherent properties of the sign-based architecture. Sign-Based Morphology is therefore a loosely paradigmatic approach with just the right properties.

Chapter 4. Cophonologies and Level Ordering

This chapter focuses on the status of level ordering (Kiparsky 1982, Mohanan 1982, Mohanan 1986) in Sign-Based Morphology. In section 4.1, I present the basic claims of level ordering theory. In section 4.3, I investigate level ordering in the Turkish lexicon, motivating five lexical strata, and develop a set of stipulations which enable Sign-Based Morphology to handle “standard” level ordering phenomena. In section 4.7, I present challenges to level ordering, and show how these challenges can be handled by abandoning each of the level-ordering stipulations made in section 4.3. Level ordering is thus not an intrinsic part of Sign-Based Morphology, putting the theory in a position to handle the many phenomena motivating departures from level ordering. By contrast, any theory that incorporates level ordering as a fundamental assumption must resort to ad-hoc devices such as the “loop” of Mohanan 1982, Mohanan 1986, or level skipping or economy (Inkelas and Orgun 1995) to handle the phenomena which counterexemplify strict ordering.

4.1 Level ordering: the standard view

In Lexical Phonology (Kiparsky 1982, Mohanan 1982, 1986), the lexicon is assumed to be divided into a number of strata. Each morphological construction is assigned to a specific stratum. Words pass through these strata in sequence, potentially undergoing morphological (and phonological) operations at each of the strata. Each stratum is associated with a particular set of phonological rules. I illustrate this with a classic example from English affixation taken from Mohanan (1982). The English lexicon is

assumed for purposes of this illustration to be divided into two strata. Essentially, Latinate morphology is assigned to stratum 1, while English morphology is assigned to stratum 2, although the generalization is not perfect. Examples of affixes belonging to these strata are shown in (176):

(176)	Stratum 1	Stratum 2
	-ate	-ing
	-al	-er
	-ity	-ee
	-ism	-ed

The expectation is that in forms containing both stratum 1 and stratum 2 affixes, stratum 1 affixes should appear inside stratum 2 affixes (as in *advoc-at₁-ing₂*).

Some of the phonological rules of the two strata are shown in (177):

(177)	Stratum 1	Stratum 2
	velar softening (k → s)	no velar softening
	stress shift	no stress shift
	no consonant deletion	consonant deletion

Examples are given in (178):

(178)	Stratum 1	Stratum 2
	electric/electricity (velar softening)	traffic/trafficking (no velar softening)
	catholic/catholicism (stress shift)	analyze/analyzing (no stress shift)
	damnation [dæmneɪʃn] (no deletion)	damning [dæmɪŋ] ([n] deletion)

A main claim in classical level-ordering theory (Kiparsky 1982, Mohanan 1982, 1986) is that every form, derived or underived, is subject to each level of the lexical phonology and morphology. Mohanan invokes a factory metaphor in which lexical levels correspond

to rooms in which workers perform phonological and morphological operations to the words being built (Mohanan 1986:47):

- (179) There is a conveyor belt that runs from the entry gate to the exit gate passing through each of these rooms. This means that every word that leaves the factory came in through the entry gate and passed through every one of these rooms.

UR → [level 1] → [level 2] → [level 3] → [level 4]

As Inkelas (1988) has shown, the hypothesis that every form undergoes every level is independent of the serial factory metaphor, however; if, following Selkirk 1982, Inkelas 1988, Cohn 1989, Inkelas 1993a, and Orgun 1994c, lexical levels are defined as hierarchically related constituent types, the same fundamental principle can be implemented. To this end Inkelas 1988 extends Selkirk's Strict Layer Hypothesis (Selkirk 1982:26), developed originally for postlexical prosodic constituents, to lexical structure:

- (180) Selkirk's Strict Layer Hypothesis: "a category of level *i* in the hierarchy immediately dominates a (sequence of) categories of level *i-1*"

Applied to lexical constituent structure:

[X] _{level 4}	
[X] _{level 3}	
[X] _{level 2}	
[X] _{level 1}	
/x/ _{level 0}	(UR)

Languages with level ordering which have been analyzed following the basic assumption of level obligatoriness include Malayalam (4 levels) (Mohanan 1982, Mohanan 1986;

English (between 2 and 4 levels) (Kiparsky 1982a,b, 1985; Mohanan 1982, 1986; Halle and Mohanan 1985); Tamil (2 levels) (Christdas 1988); Sekani (4-5 levels) (Hargus 1988); Kashaya (5 levels) (Buckley 1993); Turkish (4-5 levels) (Inkelas and Orgun 1994, 1995).

A summary of the basic claims of level ordering theory is in (181):

- (181)
- a) Levels are ordered. A node of a particular level cannot dominate a node of a higher level.
 - b) Every form is represented at every level. Levels may not be skipped.
 - c) Morphemes that belong to the same level are associated with the same phonological system.

In addition to these basic claims, each level may be cyclic or noncyclic. Since I have already shown how Sign-Based Morphology deals with cyclic as well as noncyclic phonological effects, I will not dwell on the issue cyclic versus noncyclic levels in this chapter.

4.2 Introduction to cophonologies

In Sign-Based Morphology, most of the work of level ordering is taken over by cophonologies. In this section, I present the basic idea behind cophonologies.

In a morphological construction, the phonological constraints relating the daughter node to the mother node are represented by the function ϕ . In the simplest case, there would be only one such function that operated throughout the morphology of a given language. In reality, however, things are not that simple. Often, different

morphological constructions are associated with different phonological alternations and constraints. In Sign-Based Morphology, this is handled by associating different morphological constructions with different phonological mapping functions. In such a language, each such phonological function is called a “cophonology”, a term used in the Optimality Theory literature by Inkelas et al. 1994, Inkelas and Orgun 1995, and Orgun 1995c, among others. Cophonologies handle standard level stratification effects, in which different sets of morphemes subscribe to different cophonologies. Unlike phonological levels, however, cophonologies extend even to those phonological effects that are specific to individual morphemes or morphological constructions.⁴⁰ Handling such effects with cophonologies eliminates the need for diacritic reference to morphological features in individual phonological rules or constraints, as well as positive and negative exception features (see Zonneveld 1978 for review), required in classical level ordering theory.

I now offer an illustrative example of cophonologies. The well-known $k \sim \emptyset$ alternation in Turkish deletes intervocalic velars at the end of polysyllabic roots (Lewis 1967, Underhill 1976, Zimmer and Abbott 1978, Sezer 1981a), as shown in (182):

(182)	g ^j erek ^j	‘necessity’	g ^j ere-i	‘necessity-3sg.poss’
	il ^j ik ^j	‘marrow’	il ^j i-i	‘marrow-3sg.poss’
	ajak	‘foot’	a ^j a-u	‘foot-3sg.poss’

However, this alternation is not triggered by all vowel initial suffixes. For example, [k] never deletes before the future suffix *-ed^jzek^j ~ -ad^jak* (183):

⁴⁰ The contrast between level ordering and minor rules and other cases of morpheme-specific phonology in the earlier literature is argued to be spurious by proponents of

(183)	g ^j erek ^j	‘be necessary’	g ^j erek ^j -edzek ^j	‘be necessary-fut’
	birik ^j	‘accumulate’	birik ^j -edzek ^j	‘accumulate-fut’
	burak	‘let go’	burak-adzak	‘let go-fut’

To handle this, we posit two separate phonological rule or constraint systems in Turkish, φ_1 and φ_2 , such that φ_1 deletes intervocalic velars while φ_2 preserves them. The third person possessive construction (data in (182)) is shown in (184); it subscribes to φ_1 , the velar deletion cophonology:

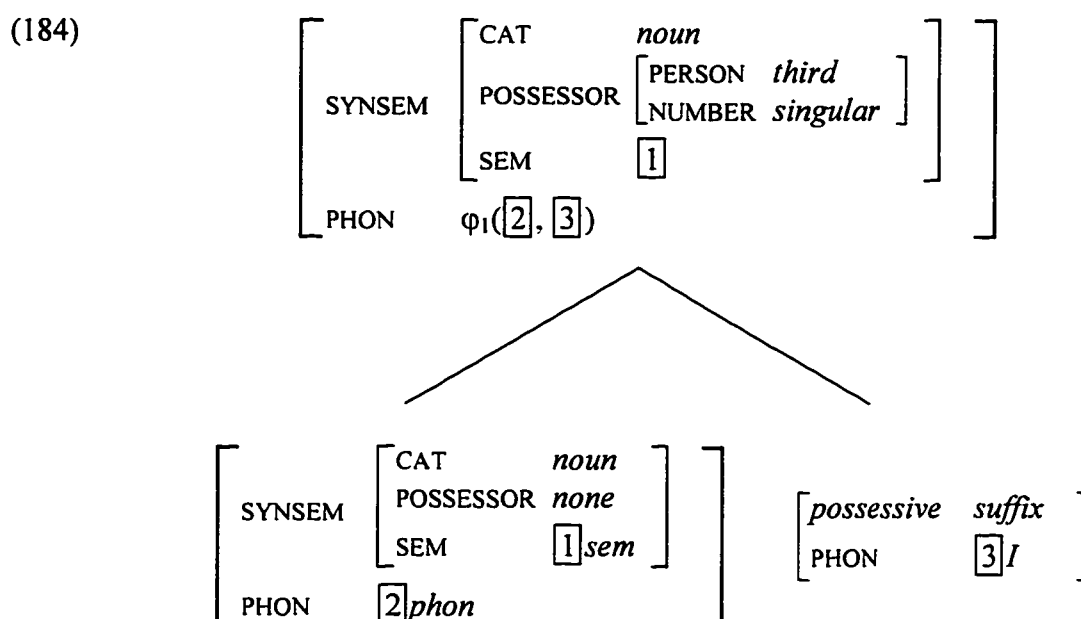

The future construction (data in (183)), on the other hand, subscribes to φ_2 , the velar-preserving cophonology, as shown in (185).

cophonologies.

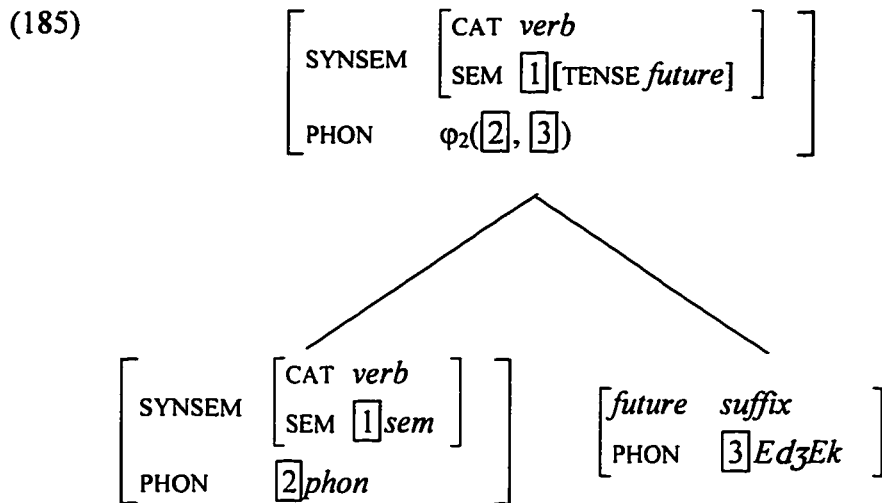

Cophonologies are the only way in which morpheme-specific phonology is handled in Sign-Based Morphology. It does not matter whether a given phonological effect is exhibited by 1, 10, or all of the morphological constructions in the language; cophonologies are responsible for them all.

By contrast, in approaches such as Lexical Phonology, cophonologies are invoked only when it appears that many morphemes (or morphological constructions) require similar phonological treatment. Phonological effects specific to one, or only a few, morphological environments are handled by other means, such as negative and positive rule features (e.g. Halle and Mohanan's (1985) level 2 [i]-tensing rule of English, stipulated not to apply before the suffixes *-ly* and *-ful* (p. 67), vs. the rule of vowel shortening, stipulated to apply before the suffix *-ic* (p. 77)). Because it depends on the undefined, relative notion of "few" vs. "many", the decision as to when morpheme-specific phonology should be attributed to a lexical stratum and when it should be handled by some other mechanism is inevitably ad-hoc and arbitrary.

By streamlining its approach to morpheme-specific phonology, Sign-Based Morphology avoids the need for arbitrary choices of this kind.

4.3 Cophonologies and level ordering

The famous $k \sim \emptyset$ alternation in Turkish (Zimmer and Abbott 1978, Sezer 1981a) was claimed by Inkelas and Orgun 1995 to provide evidence for level ordering in the Turkish lexicon. This alternation, which deletes intervocalic velars in morphologically derived environments, is, as we have already seen, triggered by some suffixes, but not others.

Some examples are provided in (186) of suffixes that do not trigger velar deletion:

(186)	$g^j edz ik^j$	$g^j edz ik^j - edz ek^j$	‘be late-(fut)’
		$g^j edz ik^j - ebil^j - ir$	‘be late-abil-imprf’
		$g^j edz ik^j - en$	‘be-late-ppl’
		$g^j edz ik^j - indz e$	‘be late-adv’
		$g^j edz ik^j - ip$	‘be late-sub’
		$g^j edz ik^j - idz i$	‘be late-agt’
		$g^j edz ik^j - i\text{ʃ}$	‘be late-noml’
		$g^j edz ik^j - erek^j$	‘be late-mnr’
		$g^j edz ik^j - ir$	‘be late-imprf’
		$g^j edz ik^j - il^j - ir$	‘be late-pass-imprf’
	$a: fak$	$a: fa: k^j - i:$	‘horizon-(adj)’

Examples of suffixes that do trigger velar deletion are given in (187):

(187)	badzak	badza-u	‘leg-acc’
		badza-u	‘leg-3poss’
		badza-um	‘leg-1sg.poss’
		badza-un	‘leg-2sg.poss’
		badza-a	‘leg-dat’
	salak	sala-um	‘stupid-1sg.sbj’
		sala-uz	‘stupid-1pl.sbj’

One way to capture this phonological difference between these two sets of suffixes is to posit two lexical strata with different phonological systems, and assign the suffixes to the appropriate stratum, as Inkelas and Orgun 1995 propose.

To determine the ordering of these two levels, it is necessary to find forms that bear suffixes from both classes. This is indeed possible in a few cases, where tense/aspect suffixes in (186) may combine with agreement suffixes in (187). In such cases, the tense/aspect suffix is inside the agreement suffix (188):

(188)	g ^j edzik ^j -edze-im	‘be late-fut-1sg.sbj’
	birik ^j -edze-i	‘accumulate-fut-3sg.sbj’
	burak-adza-un	‘let go-fut-2sg.sbj’
	g ^j erek ^j -edze-imiz	‘be necessary-fut-1pl.sbj’
	adzuk-adza-unuz	‘become hungry-fut-2pl.sbj’

Thus, a level ordered account would assign the suffixes in (186) to an earlier level than those in (187); I will call these levels 2 and 3 here (reserving level 1 for unaffixed roots) (though Inkelas and Orgun 1995 have in fact proposed a further subdivision, for other reasons, among the suffixes I am calling “level 3”.)

The effect of level ordering can be replicated in Sign-Based Morphology by using a diacritic level feature that morphological constructions refer to. This has been proposed for Turkish in Orgun 1994c (see also Selkirk 1982 and Inkelas 1989 for the claim that level is a type of category in constituent structure). I will now present this mechanism.

The main proposal is to include a diacritic level feature in signs. The structure of the form *gʲedʒikʲ-edʒekʲ* ‘be late-fut’ will then be as shown in (189). Note that the feature LEVEL is not appropriate for affixes, and is only borne by roots and morphologically complex stems (this would follow automatically if affixes were represented as arguments to the phonological function φ rather than constituents. LEVEL would then be a feature appropriate to all signs. Even though I have argued in section 3.2.2 that affixes should indeed be represented in this way, I will continue using the visually more perspicuous tree notation for the sake of easier readability).

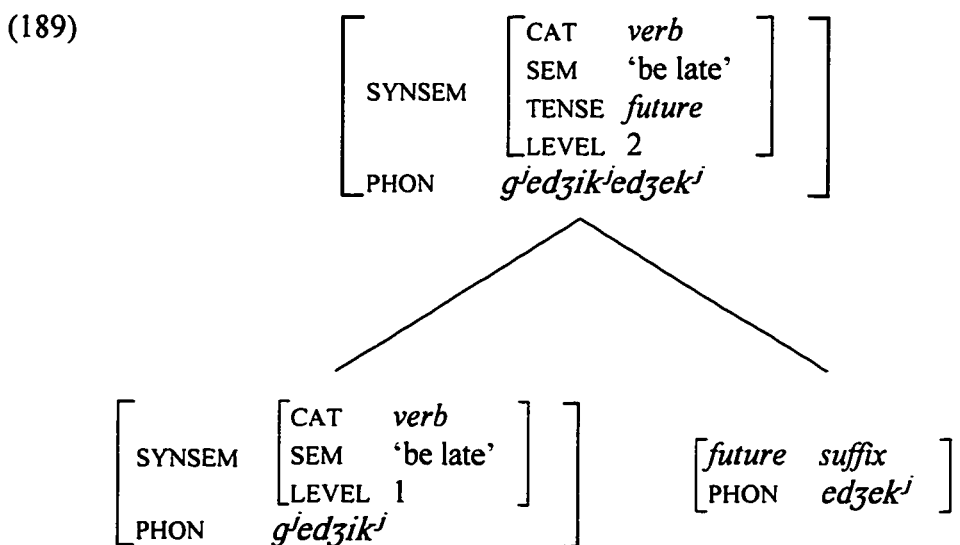

In order to complete a level ordered grammar, level specifications must be included in all morphological constructions. It is also necessary to indicate the appropriate cophonology in each construction. To this end, let φ_1 be the velar-preserving cophonology and φ_2 the velar-deleting cophonology. Recall that bare roots are assumed to be LEVEL 1, the future suffix is LEVEL 2, and the first person subject agreement suffix is LEVEL 3. The root *gʲedʒikʲ* 'be late' is shown in (190):

$$(190) \quad \left[\begin{array}{l} \text{SYNSEM} \left[\begin{array}{l} \text{CAT} \quad \textit{verb} \\ \text{LEVEL} \quad 1 \\ \text{SEM} \quad \textit{'be late'} \end{array} \right] \\ \text{PHON} \quad \textit{gʲedʒikʲ} \end{array} \right]$$

The representation of the future suffix *-edʒekʲ* is shown in (191):

$$(191) \quad \left[\begin{array}{l} \text{SYNSEM} \left[\begin{array}{l} \text{CAT} \quad \textit{verb} \\ \text{SEM} \quad \boxed{1} \\ \text{TENSE} \quad \boxed{3} \\ \text{LEVEL} \quad 2 \end{array} \right] \\ \text{PHON} \quad \varphi_1(\boxed{2}, \boxed{4}) \end{array} \right]$$

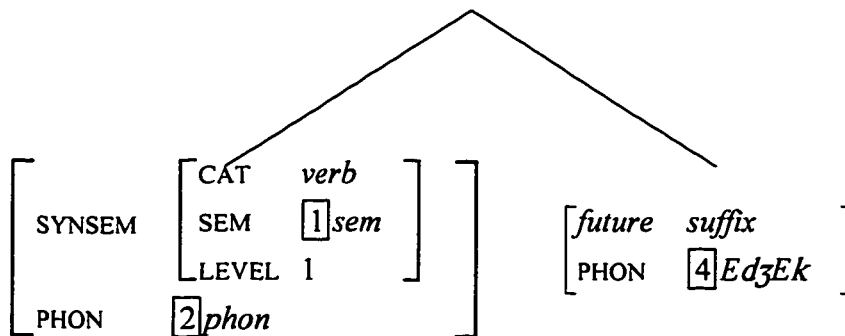

Finally, the representation of the 1st person subject agreement suffix is shown in (192):

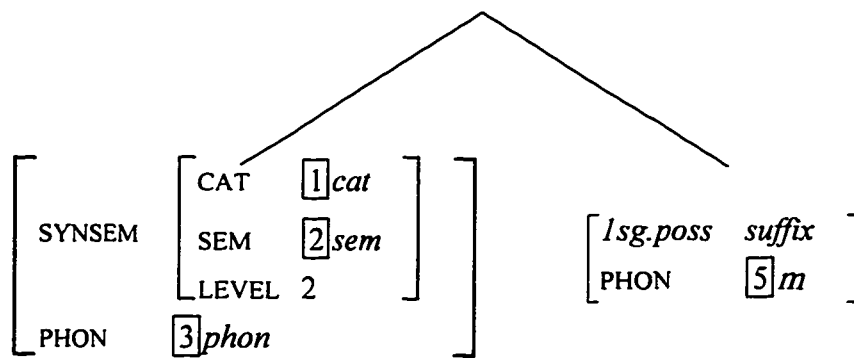
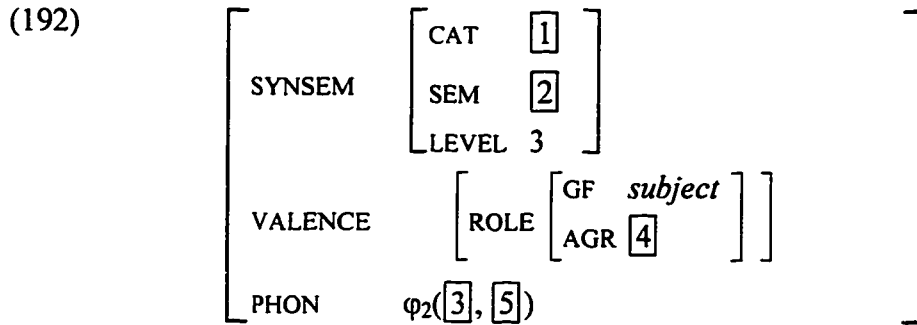

The reason that the LEVEL value of the mother node in these constructions is one higher than the LEVEL value of the daughter is that the “levels” in Turkish are all noncyclic (that is, no embedding of constituents is found within a level). The only apparent cyclic effects found result from adjunction of a higher level affix to a lower level stem. In other words, the configuration shown in (193) is, to my knowledge, not attested in Turkish:

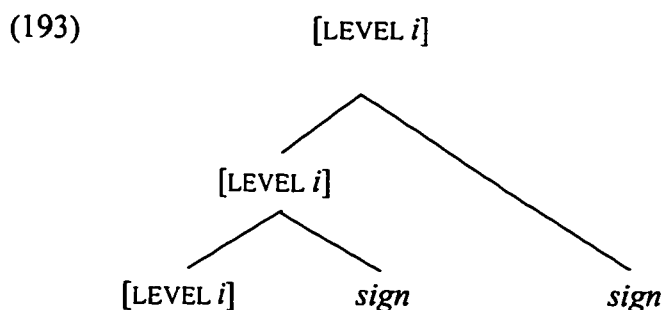

The constructions in (191) and (192) will not license the unwanted configuration in (193), since the mother node's LEVEL value is incompatible with the daughter node's, preventing recursion within the same LEVEL. At this point, we have successfully ruled out unwanted recursion, but we must still allow flat structures within a level, which are required to handle the apparent noncyclic application of the disyllabic minimal size condition in section 2.1. To do this, I use the Kleene star notation. An asterisk following a feature structure description means that there may be zero or more constituents of that description. The pluralization construction is shown in (194):

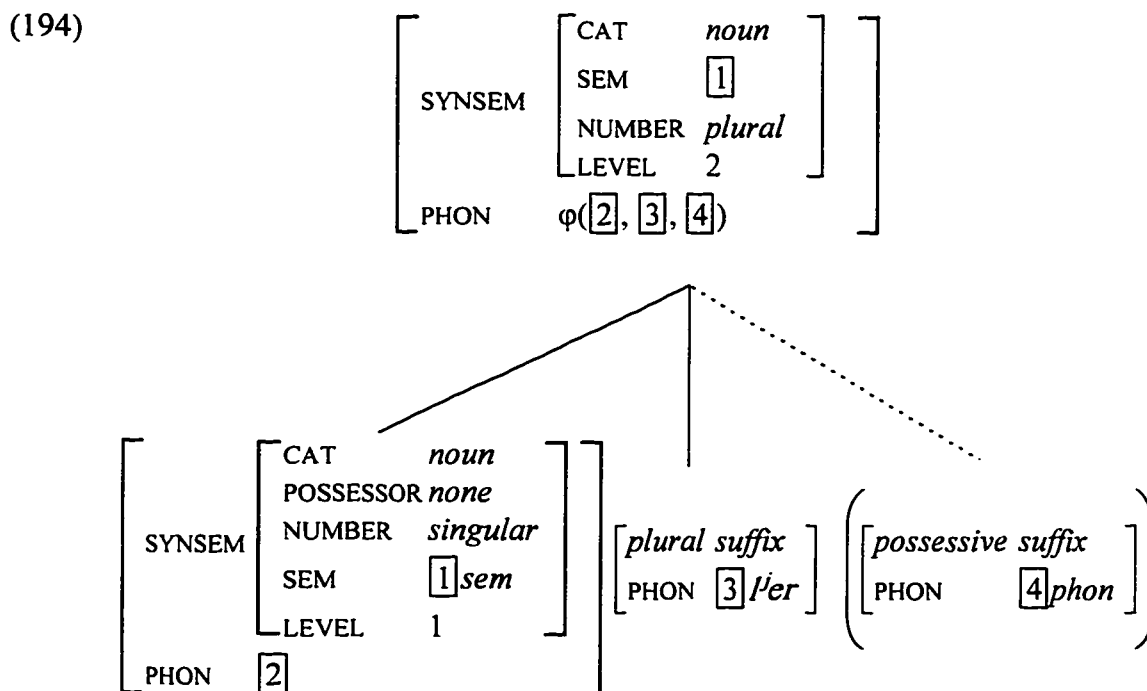

This construction attaches the plural suffix *-/er ~ -lar* to the root and allows the attachment of other suffixes to the right of the plural suffix. Of course, such attachment will only be possible if the other suffixes' constructions are compatible with the

pluralization construction in (194). One (and, as far as I know, the only) compatible construction is the first person singular possessive construction, shown in (195):

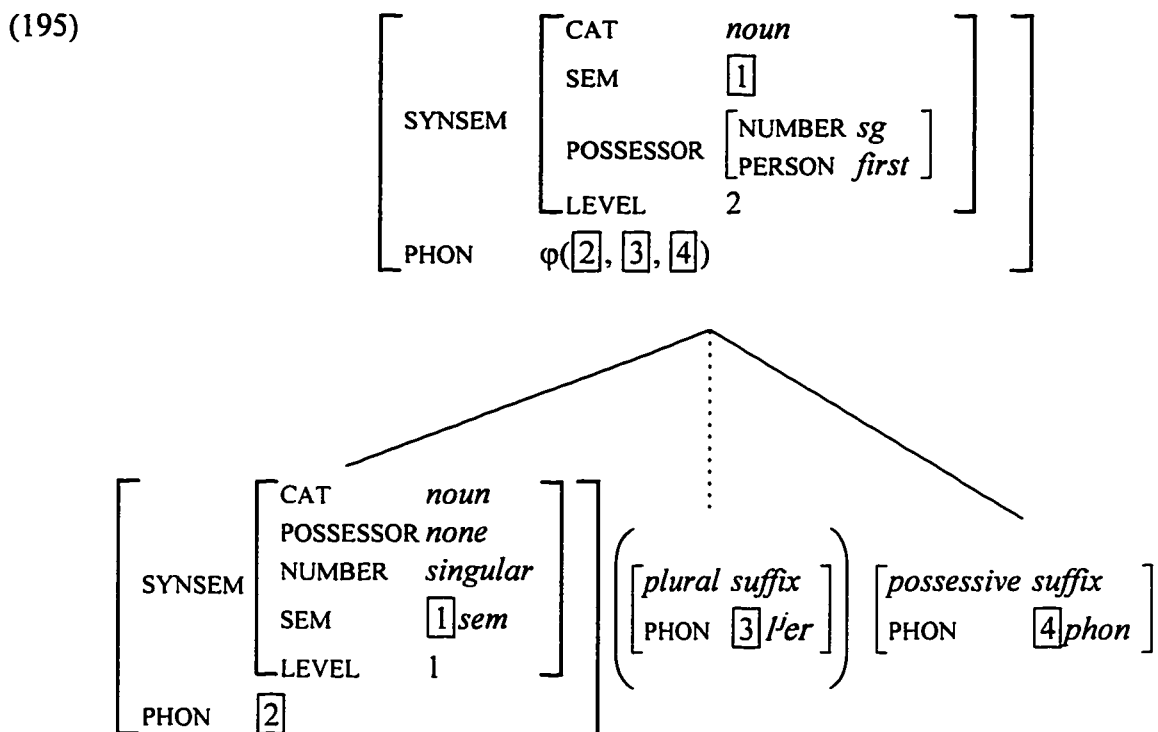

We can combine these two constructions into a general construction that can attach either the plural suffix or a possessive suffix, or both to a noun stem, provided that we adopt a number of conventions (196):

(196)

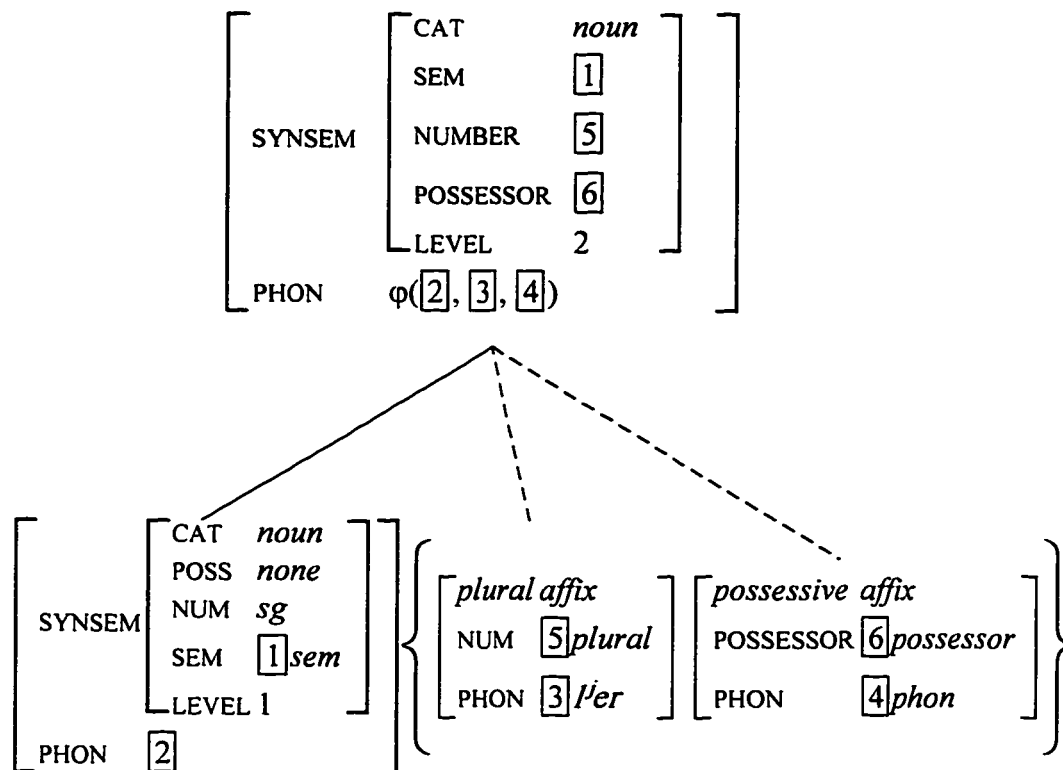

The (independently motivated) conventions that need to be invoked are the following:

- i) Vacuous nonbranching dominance is prohibited. That is, the construction in (196) cannot license an affixless structure in which a bare (singular, nonpossessed) noun stem is dominated by a singular, nonpossessed mother node. This prohibition against vacuous structure is a standard feature of Construction Grammar (Fillmore and Kay 1996), and is necessary in Sign-Based Morphology in order to derive “Level Economy” effects (see section 4.7.2)
- ii) In the absence of an affix, features of the mother node that are required by the construction to be identical to features contributed by affixes must instead be identical to corresponding features of the stem daughter. This convention is identical to the one

proposed by Lieber (1980) to control feature percolation from affixes. Within a unification-based approach, it requires the use of default percolation: features percolate from the stem by default, but this default percolation may be overridden by specific requirements imposed by affixes.

Together, the plural and possessive constructions license all of the following forms:

(197) a) Plural form

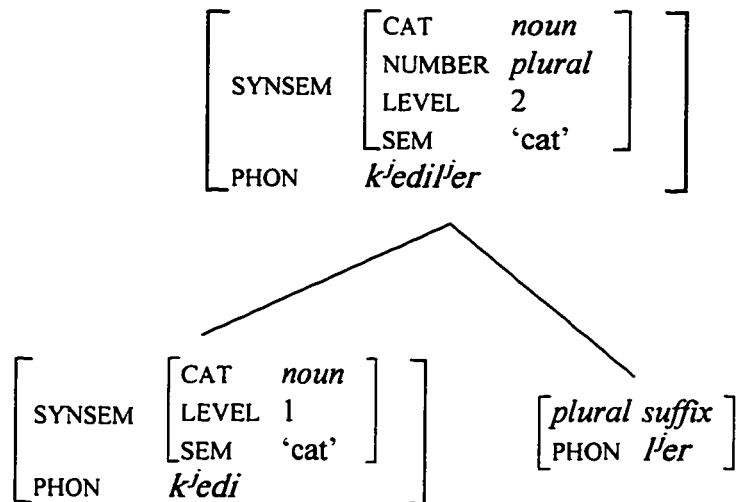

b) Possessive form

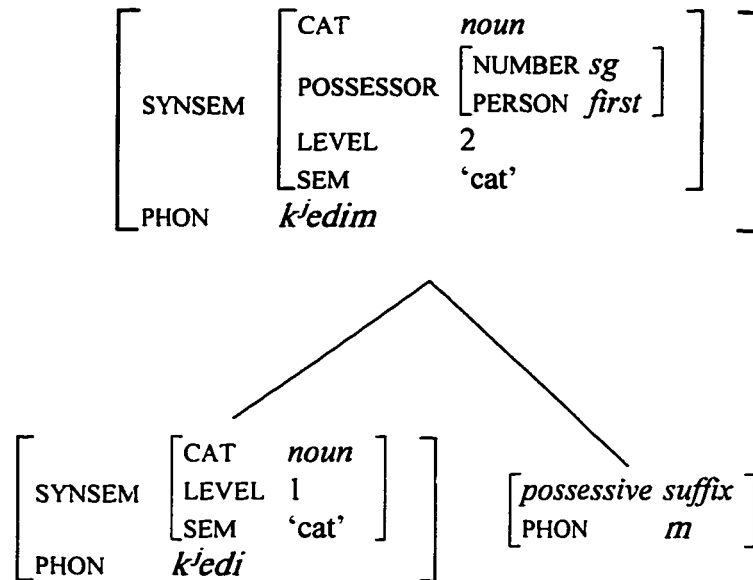

c) Plural possessive form

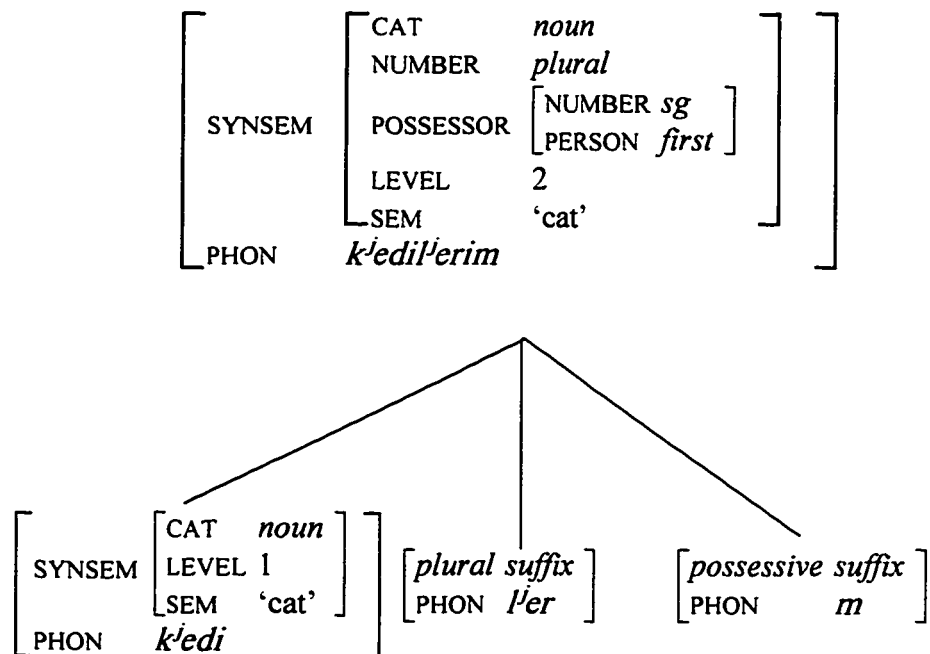

To sum up the discussion thus far, we have seen how the LEVEL feature can be used to handle level ordering phenomena (191)-(192), and also to force flat structures when appropriate (194)-(197). Of course, when recursion within a level is found (corresponding to “cyclic levels” in Lexical Phonology), the LEVEL value of the mother node of the construction in question will be the same as the LEVEL value of its daughter. An example of this would be Mandarin compounding (section 1.1). The construction that licenses Mandarin nominal compounds is shown in (198):

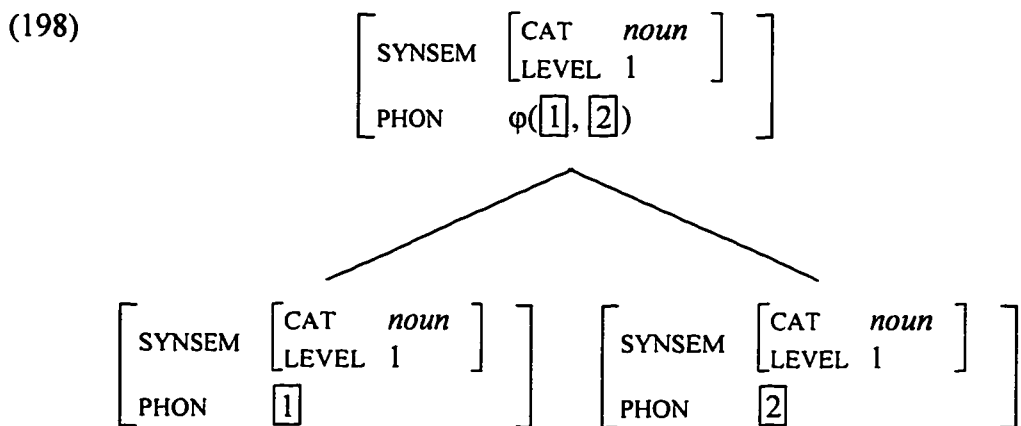

Since the daughter and mother nodes bear the same value for the LEVEL feature in this construction, the mother node of one instance can unify with one of the daughters of another instance.⁴¹ This allows embedding of compounds in compounds, which results in the observed cyclic phonological effects.

In conclusion, we have seen how level ordering phenomena can be handled in Sign-Based Morphology by using a diacritic LEVEL feature.

⁴¹ This discussion presupposes that the feature LEVEL is needed in Mandarin to begin with, for which I have no evidence at this point.

4.4 How different can cophonologies be from each other?

Any theory that allows different morphological processes to be associated with different morphophonological alternations, modeled as different phonological systems, needs to address the question of how much these different phonological systems can vary from each other. Within Lexical Phonology, two main proposals have addressed this issue: the Strong Domain Hypothesis (Kiparsky 1982), and the slightly weaker Stratum Domain Hypothesis (Mohanan 1982), also called the Uniform Domain Hypothesis (Halle and Mohanan 1985). In this section, I review these proposals and discuss the same issue from the perspective of Sign-Based Morphology, in which cophonologies are used to handle *all* morpheme-specific phonology, not just that judged somehow to be general. The question to be addressed is whether there are limits on the degree to which cophonologies in the same language can differ from one another.

4.4.1 Example of an unwanted language

In this section, I provide an example of an unattested phonological system that uncontrolled cophonology proliferation can describe. I will use this example in subsequent sections in comparing the restrictiveness of various attempted solutions to the cophonology proliferation problem.

Let this unwanted language (Hypothetical Language A) have two lexical strata, which we may term LEVEL 1 and LEVEL 2. Assume further that LEVEL 1 spreads underlying lexical tones rightward to toneless syllables, while LEVEL 2 assigns weight sensitive stress. As in Lexical Phonology, all forms undergo both levels. The LEVEL 1

tones are erased by the LEVEL 2 phonology, and stress is assigned to the leftmost heavy syllable. Some example derivations in this language are shown in (199):

(199) Hypothetical Language A:

UR	tàntáta
Level 1	tàntátá
Level 2	'tantata

In Hypothetical Language A, the first and second levels have radically different phonological systems. Since languages like this are not attested, it would seem that a satisfactory theory of the phonology-morphology interface must have a way of ruling them out. Any theory using cophonologies, whether for all phonological phenomena (Sign-Based Morphology) or only for some phenomena (Lexical Phonology) bears the burden of restricting cophonology proliferation enough to rule out unattested language types like the one described in this section.

4.4.2 The Strong Domain Hypothesis and the Uniform Domain Hypothesis

One approach to the cophonology proliferation problem was proposed by Kiparsky (1984), who proposed the Strong Domain Hypothesis as a solution. According to this hypothesis, all rules are active on LEVEL 1. Some of the rules may cease to apply on LEVEL 2. These rules may not become active again at subsequent levels. In general, a number of rules may turn off at each level, but new rules may not be added. This way, the phonological systems of different levels are prevented from differing from each other in arbitrary ways.

The Strong Domain Hypothesis works quite well for case like English, where LEVEL 1 of the lexical phonology has rules like velar softening, trisyllabic shortening and nasal deletion, while LEVEL 2 has relatively few morphophonemic alternations. However, the Strong Domain Hypothesis turns out in general to be too strong. For example, some of the phonological constraints in Turkish that have already been discussed in this work counterexemplify the Strong Domain Hypothesis. The table in (200), taken from Inkelas and Orgun 1995, summarizes the constraints and the strata on which they are active.

(200)

	Level 1	Level 2	Level 3	Level 4
velar drop	no	no	yes	yes
[σσ]	no	yes	yes	
[μμ]	yes			

Two phenomena violate the Strong Domain Hypothesis: velar deletion is inactive within roots, as well as before LEVEL 1 and 2 suffixes, but active before LEVEL 3 and 4 suffixes. Disyllabic minimality is inactive within the root level, but active on LEVEL 2 and 3 (LEVEL 4 does not have any consonantal suffixes; it is therefore impossible to determine whether disyllabic minimality is active on this level or not).

Although these phenomena counterexemplify the Strong Domain Hypothesis, they are, however, consistent with the weaker Uniform (Stratum) Domain Hypothesis of Mohanan 1982 and Halle and Mohanan 1985. According to this hypothesis, rules (or constraints) must be active in a contiguous set of levels. Thus, we may specify the earliest and latest levels on which a rule applies; the rule must be active on all the intervening levels as well. For the Turkish case, we only need to specify the earliest level at which

velar deletion and disyllabic minimality are active: LEVEL 3 for velar deletion and LEVEL 2 for disyllabic minimality.

4.4.3 How restrictive is the Uniform Domain Hypothesis?

The intent of the Uniform Domain Hypothesis is to keep the phonological systems of different levels (i.e. cophonologies) from differing from each other in arbitrary ways. In this section, I demonstrate, however, that the unwanted language type in section 4.4.1 is allowed by the Uniform Domain Hypothesis. The Uniform Domain Hypothesis is therefore not strong enough to rule out unattested types of cophonology proliferation.

In LEVEL 1 of Hypothetical Language A, the only rule to apply is tone spreading, which spreads underlying tone rightwards to all available syllables.

In accordance with the Uniform Domain Hypothesis, we posit two rules that turn on at LEVEL 2. The first of these is a tone deletion rule that deletes all tones. The second is a stress assignment rule that places word stress on the leftmost heavy syllable. The rules and their level assignments are summarized in (201):

(201)	LEVEL 1	Tone spread
	LEVEL 2	Tone deletion Stress assignment

These rules permit the derivation in (202), which corresponds to the unattested and undesired Hypothetical Language A:

(202)	UR		tàntátá
	Level 1	Tone spreading	tàntátá
	Level 2	Tone deletion Stress	tantata 'tantata

The insight behind the Uniform Domain Hypothesis is that the different phonological systems associated with the strata cannot differ from each other in arbitrary ways. However, the hypothesis is unable to curtail cophology proliferation in a satisfactory way, since it fails to rule out the unattested Hypothetical Language A, whose different levels have completely unrelated prosodic structures.

In the following sections, I speculate on possible remedies to this problem.

4.4.4 An insight from Optimality Theory: focus on the output

A leitmotif in the Optimality Theory literature is the importance of focusing on the output rather than the rules/processes (alternations) that derive that output (Prince and Smolensky 1993; see also McCarthy 1996a for a particularly forceful argument in favor of this position). In rule-based theories, certain generalizations are inevitably lost due to the focus on rules rather than outputs. It is often the case that a number of different rules “conspire” to create wellformed outputs (Kisseberth 1970). An approach like Optimality Theory is better able to offer insightful analyses of this sort of phenomenon, since an Optimality Theory grammar consists largely of output wellformedness constraints.

This insight from Optimality Theory proves to be useful in allowing us to take one more step towards a genuine understanding of the relation between cophologies in a

language. Careful inspection of empirically motivated cophonologies reveals an important generalization: the similarities that we need to capture across cophonologies are mainly in the output strings that they license. Even when cophonologies differ in major ways in the alternations they enforce, their outputs are still quite similar as a set. The unwanted Hypothetical Language A (section 4.4.1) has the opposite property: the outputs of the two cophonologies have radically different outputs.

A good demonstration of this point is provided by the Turkish cophonologies in section 4.3. Consider, for example, velar deletion. This alternation is active on levels 3 and 4, but not on levels 1 and 2. Thus, intervocalic velars are not deleted in level 1 or 2 morphology (203):

(203) Level 1	Roots:	sokak	‘street’
		sakal	‘beard’
		ek ^j ip	‘team’
		oku	‘read’
	Acronyms:	a:k ^j e:me:	‘AKM (Atatürk Cultural Center)’
Level 2	Future:	birik ^j -edzek ^j	‘accumulate-fut’
		buurak-adzak	‘let go-fut’
		g ^j edzik ^j -edzek ^j	‘delay-fut’
		g ^j erek ^j -edzek ^j	‘be necessary-fut’
	Imperfective:	birik ^j -ir	‘accumulate-imprf’
		buurak-uur	‘let go-imprf’
		g ^j edzik ^j -ir	‘delay-imprf’
		g ^j erek ^j -ir	‘be necessary-imprf’

Intervocalic velars *are* deleted in level 3 and 4 morphology (204):

(204)	Level 3	Possessive:	sokak	soka- <i>u</i>	‘street (-3sg.poss)’
			badzak	badza- <i>u</i> m	‘leg (-1sg.poss)’
			eʃek ^j	eʃe- <i>i</i> n	‘donkey (-2sg.poss)’
			mek ^j ik ^j	mek ^j i- <i>i</i> miz	‘shuttle (-1pl.poss)’
			bardak	barda- <i>u</i> n <i>u</i> z	‘glass (-2pl.poss)’
Level 4	Case:	del ^j ik ^j	del ^j i- <i>i</i>	‘hole (-acc)’	
		etek ^j	ete- <i>e</i>	‘skirt (-dat)’	
		baluk	balu- <i>u</i> n	‘fish (-gen)’	

These cophonologies thus differ in the alternations they enforce. One of them deletes intervocalic velar across morpheme boundaries, while the other does not. However, when we consider the range of phonological strings that these cophonologies license as a set, we notice that both sets of include strings with intervocalic velars as well as with vowel hiatus (205):

(205)	Intervocalic velar	Vowel hiatus
Level 1/2 output	ʃaka ‘joke’ g ^j edzik ^j - <i>i</i> p ‘delay-sub’	saat ‘clock’ tʃoal- <i>u</i> p ‘increase-sub’
Level 3/4 output	takum- <i>u</i> m ‘team-1sg.poss’ hek ^j im- <i>i</i> m ‘doctor-1sg.poss’	aadʒ- <i>u</i> m ‘tree-1sg.poss’ teti- <i>i</i> m ‘trigger-1sg.poss’

Thus, even though these two cophonologies differ in the alternations they enforce, they do not differ in the kinds of output strings they license (in terms of intervocalic velars and vowel hiatus). This suggests that attempts to restrict cophonology proliferation should focus on the output, not the alternations. This observation is in line with the major insight

Optimality Theory has provided phonological theory with: important generalizations lost by focusing on rules or alternations may be gained by focusing on the output instead.

4.4.5 A Learnability Hypothesis: Hypothetical Language B

Focusing on the output immediately suggests a way to curtail cophonology proliferation without any extrinsic constraints on the theory. A striking property of Hypothetical Language A is that the tones from level 1 never surface—they are always deleted on level 2. Let us compare this language with another, minimally different language (Hypothetical Language B) which has no underlying tones (and thus no tone rules). Level 1 therefore has no rules of interest to us. Level 2, as before, has a stress rule, but no tone deletion rule. A typical derivation in this language is shown in (206):

(206) Hypothetical Language B

UR	tantata
Level 1	tantata
Level 2	'tantata

Note that the ultimate surface outcome in Hypothetical Language B is the same as that in the undesirable Hypothetical Language A. Given this, no empirical evidence distinguishes these two languages. In the absence of positive evidence, a learner will certainly not posit an elaborate tonal system. Therefore, the unwanted Hypothetical Language A will never be learned. Instead, exposure to the same set of data will result in Hypothetical Language B being learned. Focusing on the output allows us to pinpoint the problem with the unwanted Hypothetical Language A: the problem is that the output of the inner level

contains information that is not deducible from the surface form, and is therefore unlearnable based on positive evidence.

(207) Learnability Hypothesis: cophonologies must be learnable

Clearly, more research in this area is called for before any definitive claims can be made. Tentatively, however, I suggest that there should be no universal formal constraints on cophonological variation. Cophonologies are to be allowed to differ from each other in any way, as long as their outputs satisfy some minimal conditions that every surface phonological string in the language obeys.⁴²

4.4.6 Some spurious cophonology proliferation problems

In this section, I discuss a few additional examples of cophonologies that seem to be too different from each other. I show, however, that these examples also do not point to the need for extrinsic constraints on cophonology proliferation.

The first example (Hypothetical Language C) is similar to Hypothetical Language A, except that the tones in Hypothetical Language C surface alongside stress. I argue that ruling out this situation is a problem for phonological theory proper, not a problem of cophonology proliferation. The second example involves a language (Hypothetical Language D) that has very restrictive syllable types on level 1, and allows a much wider variety of syllables on level 2. I argue that languages of this type do in fact exist. The

⁴² These conditions can perhaps be formally expressed in a construction that every word in the language must undergo, corresponding to the word level of Lexical Phonology (see especially Borowsky 1993 for discussion of the word level).

conclusion of this section is that some apparent challenges of cophonology proliferation are better seen as challenges to phonological theory in general.

4.4.6.1 A variation on the tone/stress system: Hypothetical Language C

At first sight, the Learnability Hypothesis (207) does not seem to be sufficiently restrictive. For example, it allows a minor variation on the unwanted Hypothetical Language A. In particular, suppose we remove the level 2 tone deletion rule from the grammar, but leave everything else intact. We then license the derivation in (208):

(208) Hypothetical Language C:

UR		tàntátá
Level 1	Tone spreading	tàntátá
Level 2	Stress	'tàntátá

In Hypothetical Language C, as in Hypothetical Language A, the two cophonologies are radically different from each other. Level 1 has tones, and level 2 has quantity sensitive stress. The only difference is that the tones from level 1 are not deleted on level 2. Languages like this are not attested. Does this mean that the Learnability Hypothesis (207) is not sufficiently restrictive, and must be supplemented by some stipulated formal universal constraint on cophonology proliferation?

Although the potential for describing Hypothetical Language C may seem to be a problem caused by cophonology proliferation, I claim that the problem is in fact more fundamental: the problem is within the level 2 cophonology itself, not in the difference

between level 1 and level 2. The phonology of level 2 allows tones and stress to coexist in its output strings. It is this problem that phonological theory must address. Thus, what we need is a way to constrain a single phonological system, not formally restrict differences between phonological systems within a language.

Once again, more research is necessary before any conclusive claims can be made on the desired scope of restrictions on cophonology proliferation. However, the demonstration in this section shows that restricting phonological theory may sometimes be where the real challenge lies.

4.4.6.2 Different syllable inventories: Hypothetical Language D

In this section, I present a language (Hypothetical Language D) that is allowed by the Learnability Hypothesis. In this language, level 2 allows only CV syllables, while level 1 has a larger inventory of syllable types. It appears at first that such languages should be disallowed. However, I argue that they should in fact be allowed. This claim leads to the interesting issue of how much cophonologies should be allowed to differ in the output strings they license (assuming such differences are consistent with the Learnability Hypothesis to begin with).

Let us assume that level 1 only allows CV syllables. Level 2, on the other hand, allows complex coda clusters. Let us also assume that there are a number of level 2 consonantal suffixes that can create such clusters. A typical derivation in this language is shown in (209):

(209) Hypothetical Language D

UR	beke
Level 1	beke
Level 2	beke-l-k-t-s
Surface	bekelkts

The Learnability Hypothesis does not rule out Hypothetical Language D. It is in fact quite easy to learn the system: root internally, only CV syllables are found. Suffixes, however, may create coda clusters. Should such languages be ruled out? If so, this would mean that the Learnability Hypothesis is not sufficiently restrictive, and further formal universal constraints on cophonology proliferation are called for.

I claim that languages such as the one described in this section should not be ruled out. Though the particular example discussed here is rather extreme, systems of this general kind do exist. English is a case in point. Only relatively small consonant clusters are found within English morphemes. However, suffixed forms allow much larger clusters. None of the clusters in (210) can be found in monomorphemic English forms:

(210) English is Hypothetical Language D:

pact-s	[kts]
ten-th-s	[nθs]
six-th-s	[ksθs]
ask-s	[sks]

This demonstration has an important implication: cophonologies *may* differ considerably in their outputs as long as such differentiation is consistent with the Learnability Hypothesis.

4.4.7 Review of cophonology proliferation

At first sight, it may appear that Sign-Based Morphology's use of cophonologies results in a lack of restrictiveness, compared to, for example, a theory like Lexical Phonology, which embodies principles such as the Strong Domain Hypothesis or the Uniform Domain Hypothesis to control the content of cophonologies. However, I have contended that this apparent contrast between Sign-Based Morphology and Lexical Phonology is not a real one. The main points of this argument are summarized in (211):

- (211) i) Approaches that do not use cophonologies (such as Lexical Phonology, which uses levels instead, or the approach of Benua 1995, which uses a single constraint ranking for all of morphology) are not necessarily more restrictive in empirical terms. Such approaches must allow additional tools like exceptions features or rules or constraints that make reference to specific morphemes. These tools can replicate everything that cophonologies can do. They are at least as powerful as cophonologies (section 4.4.3).
- ii) Researchers in the Lexical Phonology framework (Mohanan 1982, Kiparsky 1983, Halle and Mohanan 1985) have had the valuable insight that cophonologies within a language do not seem to vary randomly. However, the rule-based phonological theory of the time prevented them from putting this insight into good use. The output focus of Optimality Theory has provided valuable insights into all aspects of phonological

and morphological research. This same insight is important in cophonology proliferation as well: it is necessary to restrict the differences between the outputs of different cophonologies, not necessarily the alternations imposed by them (section 4.4.4).

- iii) Learnability is a sufficient criterion to rule out many cases of unwanted cophonology proliferation. In particular, if there is a cophonology that every form must undergo (a word construction), then any phonological structure that this cophonology does not preserve will be prevented by the Learnability Hypothesis from occurring in cophonologies applying to constituents (section 4.4.5).
- iv) When learnable, considerable differences between cophonologies are possible, and are attested (section 4.4.6.2).
- v) Certain problems that remain are better attacked from the perspective of restricting the flexibility of a single phonological system, not from the perspective of restricting differences between coexisting phonological systems within a language (section 4.4.6.2).

Tentatively, then, I claim that it is not necessary to impose any extrinsic universal constraints on cophonologies. Some apparent problems may disappear as phonological theory develops further. Other unwanted grammars are ruled out on the basis of

learnability. Yet other seemingly extreme cases turn out to be attested. Further research will determine the validity of this claim.

Having addressed the issue of how much the phonology of one level can differ from the phonology of another level, I go back to the central topic of this chapter, the issue of level *ordering*.

4.5 Levels in the Turkish lexicon

In this section, I motivate some additional levels in the Turkish lexicon by using Suspended Affixation, prosodic minimality, cophologies, and suffix ordering as tests. I also assign a number of suffixes to these levels. The purpose of this investigation is threefold. First, it illustrates how the mechanisms developed in section 4.3 for level ordering can handle a sizable fragment of Turkish morphology. Second, I refer to the levels motivated in this section in my discussion of departures from strict level ordering in section 4.7. Third, unlike the most familiar claim for level ordering, which is based on Latinate versus Anglo-Saxon morphology in English, all the morphological phenomena that motivate level ordering in the Turkish lexicon are fully productive. This lends the theory of level ordering more credibility by showing that claims that level ordering effects are restricted to cases where the inner level is unproductive (Bochner 1993), and that these are therefore of limited, if any, synchronic interest are incorrect.

Recall from the previous discussion of Turkish that we have assigned bare roots to level 1. The first productive suffix to be added to verb roots is the causative,⁴³ followed by the passive. We will not be concerned with the causative, since it does not interact with any of the phonological and morphological phenomena we are investigating. I will therefore assume that the passive suffix attaches to level 1 daughters, and that the mother node is level 2. Prosodic minimality tells us that tense and aspect suffixes form a flat structure with the passive. Observe the data in (212), where minimality violations can be repaired by adding further suffixes:

(212) je	‘eat’
*je-n	‘eat-pass’
je-n-ir	‘eat-pass-imprf’
je-n-ijor	‘eat-pass-prog’
je-n-edzek ^j	‘eat-fut’
je-n-di	‘eat-past’
je-n-miſ	‘eat-evid’
je-n-mez	‘eat-neg.imprf’

This apparent noncyclic application of the disyllabic minimal size condition is handled by positing a flat structure for the suffixes in question, as shown in section 2.1. The structure for *je-n-edzek^j* ‘eat-pass-fut’ is shown in (213):

⁴³ The reflexive and reciprocal suffixes precede the causative, but as they are only marginally productive, I will ignore them here, in accordance with my desire to lend more credibility to level ordering by basing it exclusively on productive morphology.

(213)

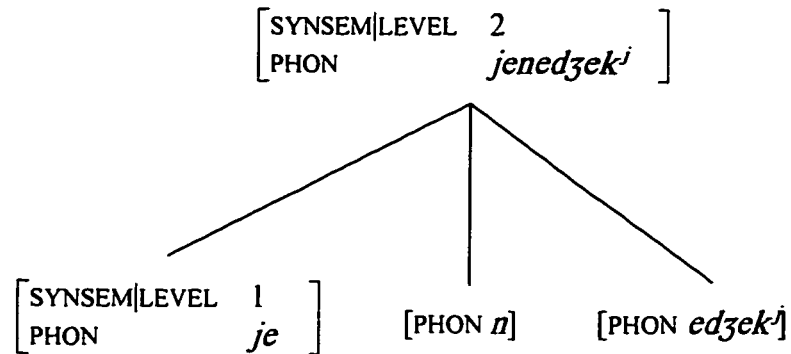

It follows from the fact that the passive and tense/aspect suffixes form a flat structure that they must all have the same level specification. Thus, tense/aspect suffixes belong to level 1 as well. Example (214) shows the level assignments we have so far. I will update this list each time I present evidence for a new level.

(214) Level 1
root

Daughter: level 1, Mother: level 2
passive *-n*
tense *-di*, etc.
aspect *-ijor*, etc.

I now turn to the plural and possessive suffixes, which will turn out to belong to a different level. We know from Suspended Affixation that these suffixes belong to the same level: the fact that they cannot be suspended separately from each other shows that they form a flat structure (215):

(215) k^jedi ve k^jøpek^j -l^jer -im
 cat and dog -pl -1sg.poss

*k^jedi -l^jer ve k^jøpek^j -l^jer-im
 -pl -pl -1sg.poss

k^jedi-l^jer-im ve k^jøpek^j -l^jer-im
 -pl-1sg.poss -pl -1sg.poss

The first person possessive suffix can be added to verbs bearing the future suffix. This is made possible by a subordinate clause construction in which the subject is genitive and which expresses subject-predicate agreement by adding possessive suffixes to the predicate. An example of this construction is given in (216). See Lewis 1967, Underhill 1976 for more. The subordinate clause is enclosed in brackets.

(216) [a^jʃe-nin gel^j-edʒe-i] ʃyphe-l^ji
 (name)-gen come-fut-3poss doubt-with
 'It is doubtful that Ayşe will come'

The possessive suffixes belong to a level higher than that of the tense/aspect ones; that is, they adjoin to hosts containing tense/aspect suffixes rather than forming a flat structure with them. The main source of evidence for this claim is that aspect suffixes subscribe to the velar-preserving cophonology, while possessive suffixes belong to the velar-deleting cophonology, as the examples in (217) show:

(217) a) Tense-aspect: velar-preserving

birik ^j	birik ^j -edzek ^j	‘accumulate-fut’
g ^j edzik ^j	g ^j edzik ^j -edzek ^j	‘be late-fut’
burak	burak-adzak	‘let go-fut’
birik ^j	birik ^j -ijor	‘accumulate-prog’
g ^j edzik ^j	g ^j edzik ^j -ijor	‘be late-prog’
burak	burak-ujor	‘let go-prog’
birik ^j	birik ^j -ir	‘accumulate-imprf’
g ^j edzik ^j	g ^j edzik ^j -ir	‘be late-imprf’
burak	burak-ur	‘let go-imprf’

b) Possessive: velar-deleting

sokak	soka-u	‘street-2poss’
bil ^j ek ^j	bile-in	‘wrist-2sg.poss’
soluk	solu-um	‘breath-1sg.poss’
e ^j fek ^j	e ^j fe-iniz	‘donkey-2pl.poss’
inek ^j	ine-imiz	‘cow-1pl.poss’

Suffixes that subscribe to different cophologies cannot form flat structures. This is because they impose incompatible requirements on the mother node’s phonology, and therefore the constructions introducing the suffixes cannot unify with each other.⁴⁴

Consider, for example, the construction for the future suffix (218):

⁴⁴ So far, we have seen three types of evidence for branching structures in Turkish. These are:

- i) Cyclic enforcement of the disyllabic minimal size condition,
- ii) Separability in Suspended Affixation,
- iii) Incompatible cophologies (level ordering).

The question of what conditions are necessary and sufficient for branching structures is an important one. In this study, I have identified sources of evidence from the

(218)

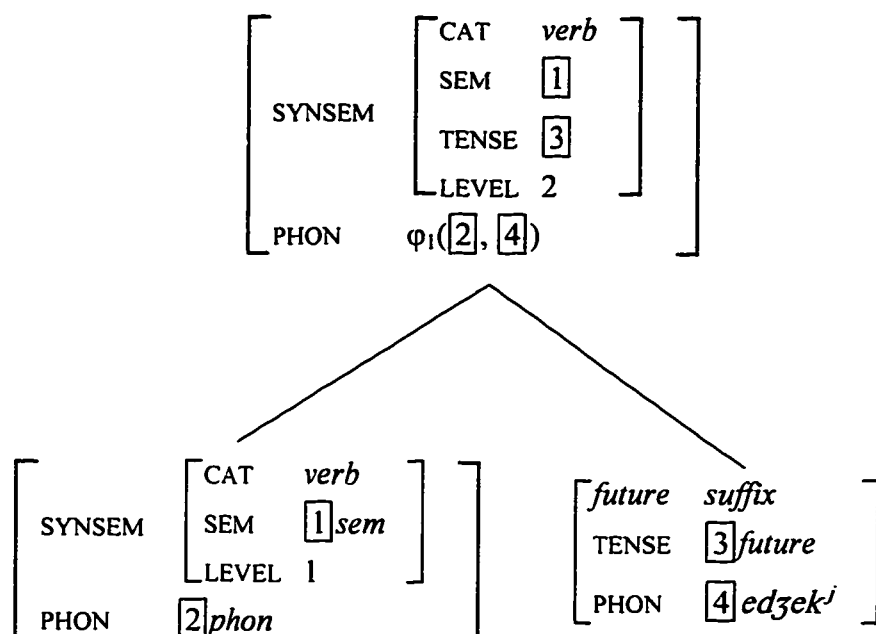

The mother node's phonology in (23) is related to the daughter nodes' phonologies by a system of constraints identified as φ_1 , which is the velar-preserving cophonology.

Now consider the construction for the first person possessive suffix (219):

phonology-morphology interface. A more comprehensive list of sufficient criteria for branching structures will have to await a thorough study of scope relations in morphology (assuming intuitively there is a relationship between scope and dominance).

(219)

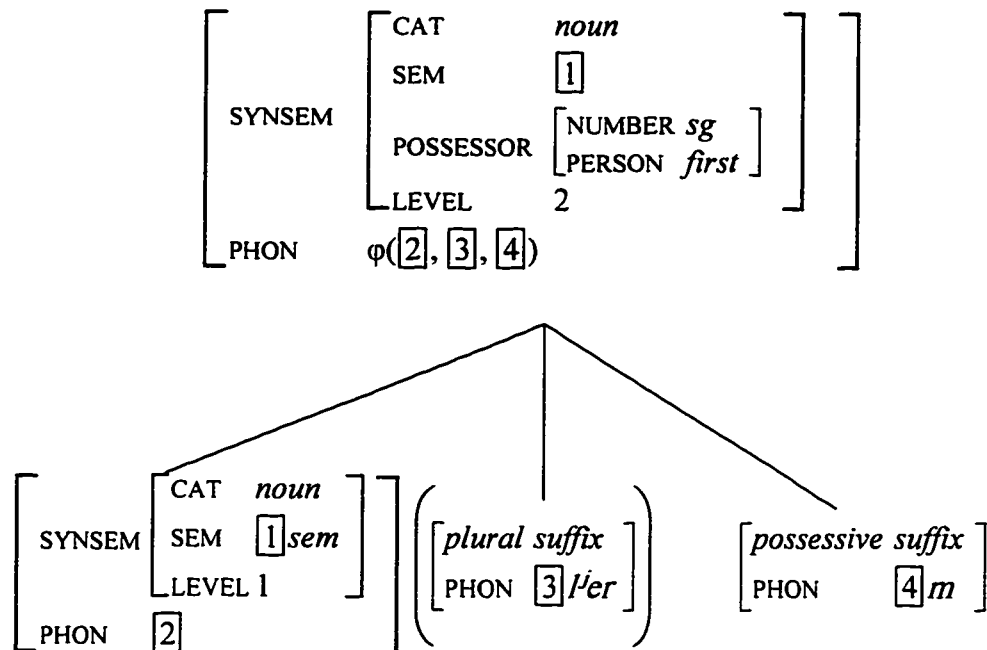

In this construction, the cophonology that relates the mother node phonology to the daughters' phonologies is φ_2 , the velar-deleting cophonology. If we were to try to put these two suffixes in a flat structure, we would be imposing incompatible constraints on the mother node's phonology. It follows therefore that aspect and possessive suffixes do not form a flat structure. Rather, the possessive suffix adjoins to stems containing the future suffix. Since the mother node of the future construction is level 2, it follows that the daughter node of the possessive construction is likewise level 2. By Strict Layering, the mother node of the possessive construction is level 3. Since the plural suffix forms a flat structure with the possessive (as we know from Suspended Affixation (215)), it follows that the plural suffix also combines with a level 2 daughter, and that the mother node is level 3.

The updated chart showing level assignments for suffixes is shown in (220):

(220)	<u>Level 1</u> root	Daughter: level 1, <u>Mother: level 2</u> passive <i>-n</i> tense <i>-di</i> , etc. aspect <i>-ijor</i> , etc.	Daughter: Level 2, <u>Mother: Level 3</u> possessive <i>-im</i> , etc. plural <i>-l'er</i>
-------	------------------------	--	---

We now turn to case suffixes, which will turn out to belong to yet another lexical stratum. Suspended Affixation shows us that case suffixes adjoin to stems containing the plural or possessive suffixes, rather than forming a flat structure with them. This is because case and plural or possessive suffixes can be suspended independently of each other (221):

(221) k^jedi ve k^jøpe -im -i
 cat and dog -1sg.poss -acc

k^jedi-m ve k^jøpe -im -i
 -1sg.poss -1sg.poss -acc

k^jedi-m -i ve k^jøpe -im -i
 1sg.poss -acc -1sg.poss -acc

The daughter node of the case constructions is therefore level 3, and, by Strict Layering, the mother is level 4. The updated level chart is in (222):

(222)	Level 1	Daughter: level 1, Mother: level 2	Daughter: Level 2, Mother: Level 3	Daughter: Level 3, Mother: Level 4
	root	passive <i>-n</i> tense <i>-di</i> , etc. aspect <i>-ijor</i> , etc.	possessive <i>-im</i> , etc. plural <i>-l'er</i>	case <i>-i</i> , etc.

This concludes my study of level ordering in the Turkish lexicon. We have seen that at least four strata are motivated. Sign-Based Morphology can handle this level stratification by using a diacritic level feature. The resulting morphological structures capture the level ordering and cophonology effects, as well as accounting for the cyclic versus noncyclic application of phonology, and restrictions on Suspended Affixation.

4.6 Modeling the Strict Layer Hypothesis

According to the Strict Layer Hypothesis, extended to lexical phonology by Inkelas 1988, 1993a, each node of level i dominates a node (or nodes) of level $i-1$ (recursion at the same level may still be allowed; what is not allowed is skipping a level, or domination of a higher level node by a lower level one). According to this proposal, nonderived forms are still represented at each level by means of unary branching structures (a direct translation of the Lexical Phonology position that all forms go through all lexical levels into structural, rather than temporal, terms). I illustrate this with the Turkish data we have seen in section 2.1. Recall that the case suffixes do not form a flat structure with possessed or plural forms. Rather, they are adjoined to the whole structure. This can be handled by specifying the daughter node of the case construction as LEVEL 2, and the mother as LEVEL 3. The accusative construction is shown in (223):

(223)

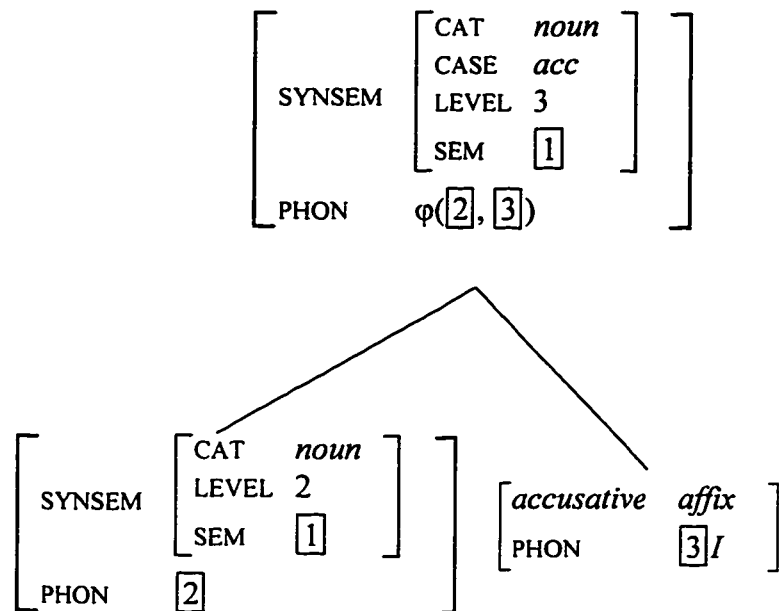

With this construction added to the grammar, we can now license the structure for *tebrik-^jerimi* ‘my congratulations-acc’ that was motivated by Suspended Affixation (section 2.2) and confirmed by prosodic minimality considerations (section 2.1). The structure is shown in (224) in highly abbreviated form:

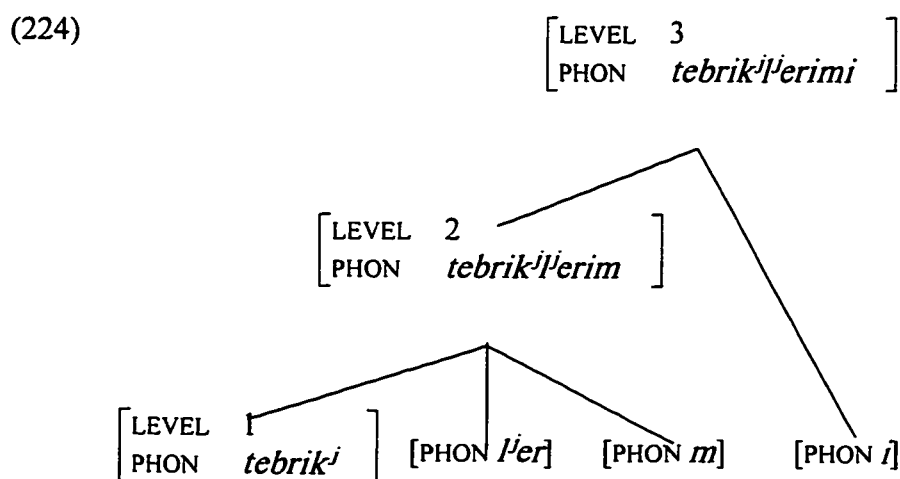

In order to complete the Strict Layer model, we need a family of nonbranching dominance constructions.⁴⁵ Some of these are shown in (225), where φ_2 and φ_3 are the cophonologies of level 2 and 3, respectively:

$$(225) \quad \begin{array}{cc} \left[\begin{array}{l} \text{SYNSEM|LEVEL 2} \\ \text{PHON} \quad \varphi_2(\boxed{1}) \end{array} \right] & \left[\begin{array}{l} \text{SYNSEM|LEVEL 3} \\ \text{PHON} \quad \varphi_3(\boxed{1}) \end{array} \right] \\ | & | \\ \left[\begin{array}{l} \text{SYNSEM|LEVEL 1} \\ \text{PHON} \quad \boxed{1}phon \end{array} \right] & \left[\begin{array}{l} \text{SYNSEM|LEVEL 2} \\ \text{PHON} \quad \boxed{1}phon \end{array} \right] \end{array}$$

These constructions license the following structure for the nonderived word *tebrik^j* ‘congratulation’ (226):

$$(226) \quad \begin{array}{c} \left[\begin{array}{l} \text{SYNSEM|LEVEL 3} \\ \text{PHON} \quad \textit{tebrik}^j \end{array} \right] \\ | \\ \left[\begin{array}{l} \text{SYNSEM|LEVEL 2} \\ \text{PHON} \quad \textit{tebrik}^j \end{array} \right] \\ | \\ \left[\begin{array}{l} \text{SYNSEM|LEVEL 1} \\ \text{PHON} \quad \textit{tebrik}^j \end{array} \right] \end{array}$$

Similarly, the form *tebrii* ‘congratulation-acc’ has the structure in (227). Notice that $\varphi_3(\textit{tebrik}^j, i) = \textit{tebrii}$.

⁴⁵ This is inconsistent with the convention, adopted earlier (196), against vacuous nonbranching dominance; however, we will shortly see that the earlier convention was in fact correct.

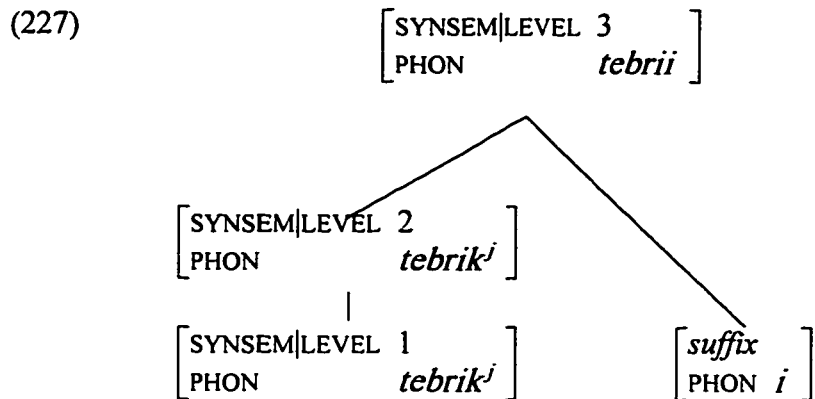

Once again, the Strict Layer Hypothesis corresponds directly to the Lexical Phonology notion that all forms undergo the phonology of every level of the lexical phonology, even if they do not undergo morphology at every level.

4.7 Challenges to level ordering

Sign-Based Morphology handles level ordering effects by making a number of stipulations. These stipulations are listed in (228):

- (228)
- a) No skipping: a node of level i may dominate a node of level $i-1$, but not a node of level $i-j$, where $j \geq 2$.
 - b) Ordering: a node of level i may not dominate a node of level $i+j$, where $j \geq 1$.
 - c) Cophonologies: each level is associated with a specific cophonology. A number of morphological constructions that share the same level specification must also share the same cophonology.

None of the conditions in (228), inherent in the Lexical Phonology view of level ordering (especially Kiparsky 1985), follow from the architecture of Sign-Based Morphology. They are all ad-hoc stipulations that need to be made in order to mirror level ordering theory within Sign-Based Morphology. In this section, I will demonstrate that there are phenomena that challenge level ordering. Each such phenomenon can be handled within Sign-Based Morphology by abandoning one of the conditions in (228). I will conclude that level ordering must not be adopted as a principle of morphological theory. These departures must be handled in Lexical Phonology by stipulating mechanisms to get around level ordering effects. In Sign-Based Morphology, on the other hand, violations of level ordering are expected. They do not require ad-hoc mechanisms.

4.7.1 Level jumping

In this and the following sections, I will discuss a number of departures from Strict Layering. Each departure will require relaxing one of the stipulations in (225). The first departure from the Strict Layer Hypothesis, to be discussed in this section, is the phenomenon of level jumping, where certain constructions cause a number of levels to be unrepresented in the constituent structure.

The data that motivate level jumping come from Nimboran, previously analyzed by Inkelas 1993b. In this section, I will provide just one example of level jumping, the durative suffix. Extensive motivation for the analysis and discussion of other cases of level jumping can be found in Inkelas 1993b.

Inkelas argues that the basic structure of the Nimboran verb is a compound. One member of this compound is the verb root, and the other member, which Inkelas calls the modifier, contains all of the suffixes. Similar proposals have been made for other languages (e.g., Halpern 1993 for Sekani, Myers 1992 for Bantu). We will be concerned with the internal structure of the modifier constituent here. Descriptively, there are eight suffix positions in the Nimboran verb such that each suffix occupies a fixed position. A partial list of morphemes and their positions is given in (229):

(229)	Root	Modifier							
	0	1	2	3	4	5	6	7	8
	root	pl.sbj	du.sbj pl.obj	m.obj dur part	inc.du.sbj	loc	iter	tense	sbj.pers

Only one morpheme may occur in each of these positions. Morphemes that are in the same column in (229) may never cooccur, even when semantically compatible. Some examples of verbs with suffixes from various positions are shown in (230). These examples illustrate the full range of subject marking available in Nimboran:

(230)	0	1	2	7	8	
	ngedúo			d	u	
	draw.sg			fut	1	'I will draw (here)'
	ngedóu		k	d	u	
	draw		du.sbj	fut	1	'We two will draw (here)'
	ngedói	i		d	u	
	draw.pl	pl.sbj		fut	1	'We (many) will draw (here)'

When there is a plural object suffix present, the possibilities for subject marking are reduced. In particular, the dual subject suffix may not be added to forms that contain the plural object marker. The full range of possible subject marking patterns in the presence of the plural object suffix are shown in (231):

(231)	0	1	2	7	8	
	ηgedóu		dár	d	u	
	draw		pl.obj	fut	1	'I will draw them (here)'
	ηgedói	i	dár	d	u	
	draw.pl	pl.sbj	pl.obj	fut	1	'We (many/two) will draw (here)'

A similar case of blocking occurs between the durative and the masculine object marker, both of which occupy position 3. Example (232) shows the contrast between the presence and absence of the masculine object marker in verbs that are not durative:

(232)	0	3	6	7	8	
	príb	rár	be	d	u	
	throw	m.obj	loc	fut	1	'I will throw him from here to above'
	príb		be	d	u	
	throw		loc	fut	1	'I will throw Ø from here to above'

As shown in (233), masculine object marking is impossible when the durative marker is present:

(233)	0	3	6	7	8	
	príb	tam	be	t	u	
	throw	dur	loc	pres	1	'I am throwing him/Ø from here to above'

In general, only one suffix may occupy a given position. If more than one suffix competes for a given position, only one may be used, and the resulting form is ambiguous as to the feature normally expressed by the suffix that is excluded due to this position class restriction.

There are, however, more complicated types of position class blocking in Nimboran. The durative marker, already shown to block the position 3 masculine object marker in (233) turns out to block position 2 suffixes (dual subject and plural object) as well. The example in (234) illustrates the contrastive use of the dual subject suffix:

(234)	0	1	2	3	7	8	
	ŋgedóu		ke		t	u	
	draw		du.sbj		pres	l	‘we two draw (here)’
	ŋgedói	i			t	u	
	draw.pl	pl.sbj			pres	l	‘we (many) draw (here)’

When the durative suffix is present, dual subject marking is not possible. The plural subject suffix is then ambiguous between a dual and strict plural reading (235):

(235)	0	1	2	3	7	8	
	ŋgedói	i	tám		t	u	
	draw.pl	pl.sbj	dur		pres	l	‘we (many/two) are drawing (here)’

It is as if the durative suffix occupies both position 2 and position 3, as indicated by placing the suffix between the two columns corresponding to these positions in (235). The question is how to formalize this. As background information, I will take for granted the following constituent structure (236) for the modifier that Inkelas proposes.

Motivation for this structure comes from complex blocking interactions that we do not need to be concerned with here (see Inkelas 1993b).

(236)

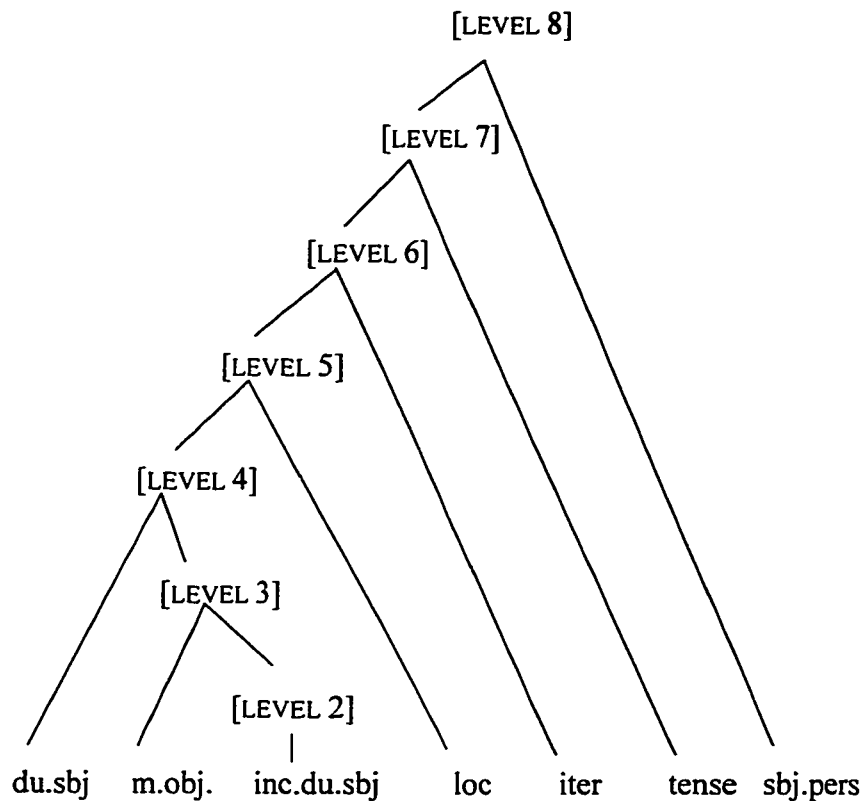

It is clear that the affixation constructions of Nimboran are like those of Turkish in that they take a daughter node of LEVEL i and yield a mother node of LEVEL $i+1$. The difference is that there are no flat structures in Nimboran, which results in the restriction that only one affix may occupy each level. Following Inkelas 1993b, we can handle the durative affix, which block level 2 and 3 affixes, quite simply in this model: the mother is LEVEL 4, rather than the expected LEVEL 3 (237):

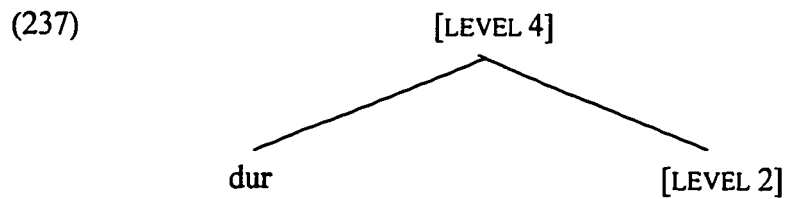

This representation allows the durative to combine with the position 4 inclusive dual subject marker, as well as suffixes of position classes 5-8, but does not allow it to combine with suffixes of position classes 2 and 3, just as desired. Notice that this solution forces LEVEL 3 of the morphology to be skipped. This violates Strict Layering, as well as the equivalent Lexical Phonology principle that every form goes through every lexical stratum. Inkelas presents other examples that cause different levels to be skipped in Nimboran.

This completes our survey of level jumping, the first type of departure from Strict Layering.

4.7.2 Level economy

One of the major tenets of Lexical Phonology is that every form, derived or underived, is subject to the phonology of every level, as discussed in section 4.1. In section 4.7.1, I have shown that specific morphological constructions may cause lexical levels to be skipped. In this section, I present data that motivate a more general phenomenon of level skipping. The Turkish data I discuss in this section involves skipping of some lexical strata by forms that do not undergo morphology at those strata (Inkelas and Orgun 1995). Even though Inkelas and Orgun 1995 use level ordering in their analysis of Turkish, the data they present requires a significant departure from the standard model. In this section,

I will briefly go over the relevant data and discuss its implications. The phenomenon we are interested in is the disyllabic minimal size condition that we have already seen. For some speakers of Istanbul Turkish, suffixed words are ungrammatical if they contain only one syllable (238):

(238)	*lʲɑ:-m	‘musical note A-1sg.poss’	solʲ-ym	‘musical note G-1sg.poss’
	*si:-m	‘musical note B-1sg.poss’	si:-si	‘musical note B-3sg.poss’
	*do:-m	‘musical note C-1sg.poss’	do:-muz	‘musical note C-1pl.poss’
	*re-n	‘musical note D-2sg.poss’	re:-niz	‘musical note D-2pl.poss’
	*mi:-n	‘musical note E-2sg.poss’	mi:-lʲer-i	‘musical note E-3pl.poss’
	*ɑ:-m	‘letter A-1sg.poss’	ɑ:-muuz	‘letter A-1pl.poss’
	*be:m	‘letter B-1sg.poss’	be:-si	‘letter A-3sg.poss’
	*dʒe:-n	‘letter C-2sg.poss’	dʒe:-niz	‘letter C-2pl.poss’
	*de:-n	‘letter D-2sg.poss’	de:-lʲer-i	‘letter D-3pl.poss’

According to our level ordering schema in section 4.4, the possessive suffixes belong to level 1. That is, they combine with a level 1 daughter, and their mother node is level 2. The cophonology associated with this level is φ_1 , which enforces the disyllabic minimal size condition. The first person possessive construction is shown in (239) (the fact that this suffix forms a flat structure with the plural is ignored here. See (195) for a more accurate representation of this construction):

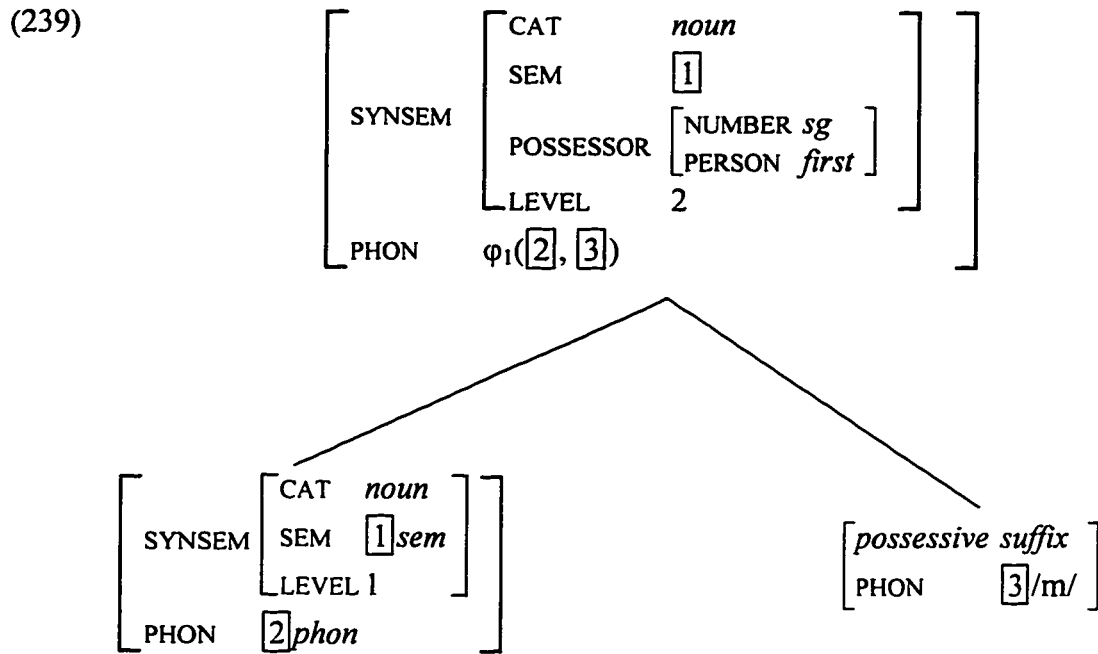

There are two ways to handle the disyllabic minimal size condition. The first way is to define φ_1 such that it will not have any output for a subminimal input. That is, $\varphi_1(\textit{do:}, m)$ (for example) would be undefined. The other way is to let φ_1 define an output in such cases, but declare that output ungrammatical by imposing the disyllabic minimal size condition on all level 2 constituents. These two ways of dealing with minimality are empirically equivalent, and I will therefore not dwell in the issue here, and will arbitrarily assume that the former option as to be used.

Now, for forms that do not bear the possessive suffix, the Strict Layer Hypothesis requires us to use the following construction (240):

(240)

$$\begin{array}{c} \left[\begin{array}{l} \text{SYNSEM|LEVEL 2} \\ \text{PHON} \quad \varphi_1 \boxed{1} \end{array} \right] \\ | \\ \left[\begin{array}{l} \text{SYNSEM|LEVEL 1} \\ \text{PHON} \quad \boxed{1} \textit{phon} \end{array} \right] \end{array}$$

According to this, the partial structure of the unsuffixed form *k^jedi* ‘cat’ is as follows

(241):

(241)

$$\begin{array}{c} \left[\begin{array}{l} \text{SYNSEM|LEVEL 2} \\ \text{PHON} \quad \textit{k}^j \textit{edi} \end{array} \right] \\ | \\ \left[\begin{array}{l} \text{SYNSEM|LEVEL 1} \\ \text{PHON} \quad \textit{k}^j \textit{edi} \end{array} \right] \end{array}$$

However, there is a serious problem with this approach: it predicts that nonderived monosyllabic forms should be ungrammatical as well, since φ_1 will have no output for such inputs. In fact, there is a large number of nonderived monosyllabic forms in the Turkish lexicon, a small sample of which is given in (242):

(242)	atʃ	‘hungry’	aʃ	‘food’
	at	‘horse’	ak	‘white’
	as	‘hang’	an	‘commemorate’
	bas	‘press’	bat	‘sink’
	bak	‘look’	ban	‘dunk’
	ben	‘mole’	bez	‘cloth’
	bit	‘louse’	bitʃ	‘mow’
	bin	‘mount’	bilʲ	‘know’
	dilʲ	‘tongue’	dip	‘bottom’
	gem	‘bit’	gam	‘sorrow’
	kʲilʲ	‘clay’	kol	‘arm’
	sol	‘left’	sap	‘stem’
	hap	‘pill’	ham	‘unripe’
	telʲ	‘wire’	tok	‘full’

The structure for the form *at* ‘horse’ is shown in (243):

$$(243) \quad \left[\begin{array}{l} \text{SYNSEM|LEVEL 2} \\ \text{PHON} \quad \varphi_1(at) = \bar{} \end{array} \right]$$

$$\quad \quad \quad |$$

$$\quad \quad \quad \left[\begin{array}{l} \text{SYNSEM|LEVEL 1} \\ \text{PHON} \quad at \end{array} \right]$$

The symbol $\bar{}$ represents an inconsistent feature structure, that is, a description that is not satisfied by any entity. In other words, it is a notation for an illegal (ungrammatical) structure. The problem is that, monosyllabic nonderived forms are grammatical in Turkish. Inkelas and Orgun 1995 take this to motivate their proposal, level economy, according to which forms do not undergo phonology at the levels at which they do not undergo morphology. According to this proposal, the structure of the word *kʲedi-ji* ‘cat-acc’, which contains the level 3 accusative suffix would be as follows (244):

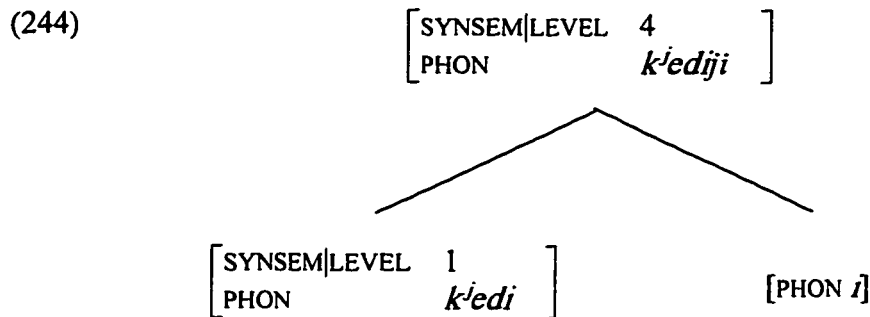

We still say that the accusative is a level 3 suffix, because it will not combine with a daughter of level higher than 3. It will, however, combine with a daughter of any level up to 3, according to level economy.

In this section, I have shown that one of the stipulations that give rise to level ordering effects must be abandoned. In particular, the stipulation that levels may not be skipped causes problem. It must be replaced by a convention that levels are always skipped unless a morphological construction of a particular level applies. Without going into formal details, it might be noticed that this is the expected state of affairs in a construction-based understanding of morphology. Application of phonology is handled by the function ϕ relating the mother node's phonology to its daughters' phonologies in each construction. When a morphological construction does not apply, there is no way to get the corresponding phonology to apply.

4.7.3 The loop

The first type of challenge we have seen to the Strict Layer Hypothesis, level jumping, had to do with morphological constructions that causes a stratum of the lexicon to be skipped. In those constructions, the level of the mother node was higher than expected. In

the second type of challenge, the level of the mother node is lower than that of the daughter node. This is handled by “the loop” in Lexical Phonology, a mechanism that sends forms back to earlier levels of the stratum ordered derivation. Examples of the loop have been proposed by Mohanan 1982, Mohanan 1986, Hargus 1988, Hualde 1988, Szpyra 1989. In this section, I present an example from Turkish that has been discussed in Inkelas and Orgun 1996.

As Hankamer (1986) has observed, Turkish has a fair amount of recursive morphology in which certain suffixes may occur repeatedly in a word. One of the suffixes that causes such recursion is the relativizer *-ki*. Examples of recursion caused by this suffix are shown in (245):

(245) ev		
house		'house'
ev-l ^h er		
house-pl		'houses'
ev-l ^h er-de		
house-pl-loc		'in the houses'
ev-l ^h er-de-k ^j i		
house-pl-loc-rel		'the one in the houses'
ev-l ^h er-de-k ^j i-l ^h er		
house-pl-loc-rel-pl		'the ones in the houses'
ev-l ^h er-de-k ^j i-l ^h er-in		
house-pl-loc-rel-pl-gen		'of the ones in the houses'
ev-l ^h er-de-k ^j i-l ^h er-in-k ^j i		
house-pl-loc-rel-pl-gen-rel		'the one that belongs to the ones in the houses'
ev-l ^h er-de-k ^j i-l ^h er-in-k ^j i-l ^h er		
house-pl-loc-rel-pl-gen-rel-pl		'the ones that belongs to the ones in the houses'
di:dem		(name)
di:dem-in		
Didem-gen		'Didem's'
di:dem-in-k ^j i		
Didem-gen-rel		'the one that is Didem's'
di:dem-in-k ^j i-l ^h er		
Didem-gen-rel-pl		'the ones that are Didem's'
di:dem-in-k ^j i-l ^h er-in		
Didem-gen-rel-pl-rel		'of the ones that are Didem's'

There are no principled limits on how much recursion is allowed. The relativizer *-kʲi* attaches to nouns that have case suffixes, which makes it a level 3 suffix according to the schema in section 4.4. That is, the daughter node of the relativization construction is level 3. The question is, what level is the mother node? It has to be compatible with the requirements of the plural suffix, which can follow *-kʲi*. We have already established that the plural suffix attaches to level 1, and not higher, nouns. Thus the level of the mother node of the *-kʲi* construction must be 1. The construction is shown in (246) (the semantics is omitted because of the complexity of its representation. The meaning of *-kʲi* is roughly equivalent to that of a relative clause):

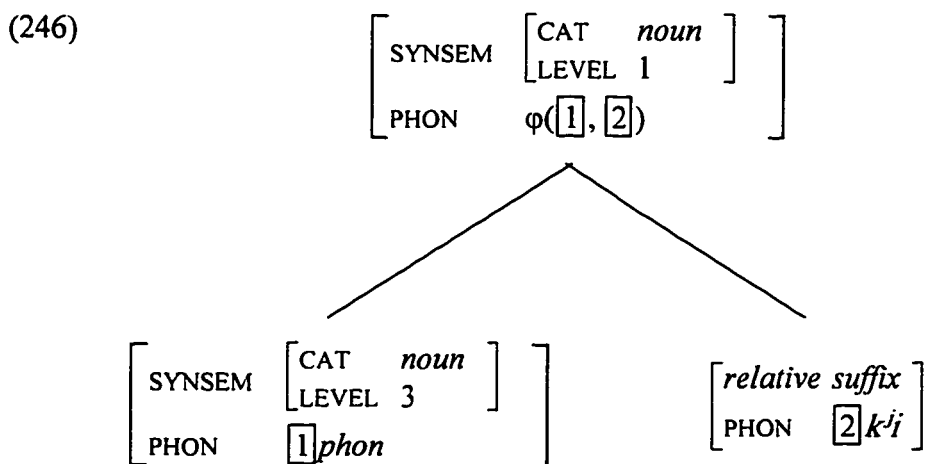

This is an example of a looping construction. Like the Nimboran durative, Turkish *-kʲi* forces a violation of the Strict Layer Hypothesis, though in a different way.

Other examples of constructions in Turkish in which the level of the mother is lower than that of the daughter can be found in Inkelas and Orgun 1996. I present some of those examples here, as well as additional ones.

One of the constructions we are interested in forms place names out of any word. It is identified by the unique non-final stress it enforces (Sezer 1981b, Inkelas 1994, Inkelas and Orgun 1996). As illustrated in (247), the final syllable is ignored, and stress falls on the antepenultimate syllable if the penult is light and the antepenult is heavy. In all other cases, stress falls on the penultimate syllable. Following Inkelas and Orgun 1995, I call this stress pattern Sezer stress, after its discoverer.

- (247) ΗΉσ is.tán.bul, an.tál.ja, hak^j.k^já:ri, us.pár.ta
 ΗΛσ án.ka.ra, mér.dzi.mek^j, bó^l.va.din, mén.te.fe
 ΛΉσ e.dír.ne, ha.li.kár.nas, ma.láz.g^jirt, ta.ráb.ja
 ΛΛσ a.dá.na, fa.sé.^lis, symé^lja

Sezer stress is not just a static regularity in the Turkish lexicon. When existing words are used as place names, they revert from default final stress to the Sezer pattern (248):

(248)	Word		... used as place name
	(Final stress)		(Sezer stress)
	bebék ^j	‘baby’	bébek ^j
	áfjón	‘opium’	áfjon
	mentefé	‘hinge’	méntefe

Even more interestingly, suffixed words can be used as place names, and when they do, they assume Sezer stress (249):

(249)	Suffixed word	... used as place name
		(Sezer stress)
a)	HHσ	
	kan.dil ^j .-l ^j i	‘oil lamp-with’ → kan.dil ^j .l ^j i
	aj.ran-dʒu	‘yogurt drink-agt (=yogurt drink seller)’ → aj.rán.dʒu
	kuz.gun-dʒúk	‘raven-Dim.’ → kuz.gún.dʒuk
	øk ^j syz-l ^j y	‘orphan-with (=with orphans)’ → øk ^j .syz.l ^j y
b)	HLσ	
	sir.k ^j e-dʒi	‘vinegar-agt (=vinegar seller)’ → sír.k ^j e.dʒi
	tor.ba-luí	‘bag-with’ → tór.ba.lu
	kuʃ-tʃu-lú	‘bird-agt-with (=with bird keeper)’ → kúʃ.tʃu.lu
	def-ti-ín	‘make hole-rel-2sg (=the one you made a whole in)’ → déʃ.ti.in
	k ^j es.ta:.ne-l ^j ík ^j	‘chestnut-for’ → k ^j es.tá:.ne.l ^j ík ^j
c)	LHσ	
	ka.vak-luí	‘poplar-with’ → ka.vák.lu
	ku.lak-suíz	‘ear-without’ → ku.lák.suz
	be.en-dík ^j	‘like-past-1pl (=we liked)’ → be.én.dík ^j
	e.min-l ^j ík ^j	‘Emin-for’ → e.mín.l ^j ík ^j

d)	LLσ	o.va-dʒúk	‘valley-dim’	→	o.vá.dʒuk
		bo.ja-dʒú	‘paint-agt (=painter)’	→	bo.já.dʒu
		baʃar-án	‘succeed-rel (one who succeeds)’	→	ba.ʃá.ran
		ba.ka.dʒák	‘look-fut (=s/he will look)’	→	ba.ká.dʒak

I now present a summary of Inkelas’s (1994) analysis of the Sezer stress pattern. The main ingredients of the analysis are the following: a single trochaic foot is assigned at the right edge of a Sezer stem. A higher-ranking constraint against a heavy syllable followed by a stressed light syllable forces this foot to be placed one syllable to the left when the penult is light and the antepenult is heavy. The constraint that requires all feet to be trochaic is never violated, and will not be shown in the tableaux. Neither will LEX≈PR, the constraint requiring every stem to have a foot. The constraints that interest us are an alignment constraint that requires the foot to be at the right edge, and the higher-ranking CONTOUR constraint (*σ_μσ_μ):

(250)	LEX≈PR	All Sezer stems must have a foot
	TROCHEE	Feet are trochaic
	ALIGN(Foot, R, Word, R)	All feet are at the right edge
	*σ _μ σ _μ	A heavy syllable may not be followed by a stressed light syllable
	Ranking:	*σ _μ σ _μ » ALIGN(Foot, R, Word, R)

The tableaux in (251) show how this ranking accounts for Sezer stress:

(251)	/kandi ^h ɸi/	*σ _μ σ _μ	ALIGN-R
	kándi ^h ɸi		*!
	☞ kandi ^h ɸi		

	/k ^h esta:neɸik ^h /	*σ _μ σ _μ	ALIGN-R
	k ^h ésta:neɸik ^h		**!
	☞ k ^h está:neɸik ^h		
	k ^h esta:neɸik ^h	*!	

	/emin ^h ɸik ^h /	*σ _μ σ _μ	ALIGN-R
	émin ^h ɸik ^h	*!	
	☞ emín ^h ɸik ^h		

	/baʃaran/	*σ _μ σ _μ	ALIGN-R
	báʃaran		*!
	☞ baʃáran		

I will refer to this cophonology as φ_s in constructions. The Sezer place name construction is depicted in (252):

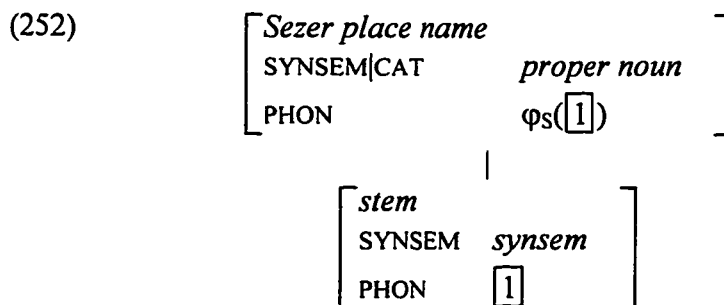

At this point, we must determine the level of the daughter and mother nodes of the Sezer place name construction. First, let us consider the level of the daughter. Examples are given in (253), where the level of the mother node of each word that is input to the Sezer place name construction is indicated:

(253)	Level	Word	Gloss	Place name
	1	bebék ^j	‘baby’	bébek ^j
	2	baġar-án	‘succeed-rel’	baġáran
	3	deġ-ti-ín	‘puncture-past- 2sg.poss’	déstiin

As we see, the Sezer construction can apply to forms that contain a level 3 suffix. Let us then assume that the level of the daughter is specified as 3 (we know that it cannot be lower than 3, or inputs such as (50) would be excluded). Now, let us look at the level of its mother. Sezer place names can themselves be input to considerable suffixation. Most obviously, they, like all other Turkish nouns, are inflected for case and number, and can be possessed. The lowest level that nominal suffixes attach at is level 2, represented by the plural and possessive suffixes. The plural suffix does not attach to place names for semantic reasons. The possessive suffix, however, may be attached; the resulting word is often used to express affection (254):

(254)	Place name	Place name-poss
	istánbul	istánbul-um
	bébek ^j	bébe-im

It appears therefore that the Sezer place name construction is another example of a loop, that is, a construction whose mother node is of a lower level than its daughter.

Compounding, another construction discussed by Inkelas and Orgun, also appears to be an example of “the loop”. Some examples of compounds with suffixes inside are shown in (255)-(259):

(255) Past tense suffix -DI (level 2)

Compounds containing -DI ‘past’ suffix

[mi:rás+je- <u>dí</u>] _N	‘inheritance-eat-past (= profligate)’
[ser-dén+g ^j etʃ-ti] _N	‘suicide squad’
[sinek ^j +ka ^j - <u>du</u>] _{Adj}	‘fly+slip-past (= close-shaving face)’
[hynk ^j ar+been- <u>dí</u>] _N	‘sultan+approve-past (= eggplant dish)’
[imam+baju ^l - <u>du</u>] _N	‘imam+faint-past (= eggplant dish)’
[vur-du-m+duj-máz] _{Adj}	‘hit-past-1sg+feel-neg.imprf (= inattentive)’
[kap- <u>tu</u> +katʃ-tu] _N	‘grab-past+run off-past (= minibus)’

(256) Case endings (level 4)

Compounds containing case suffixes:

[g ^j yn- <u>é</u> +bak-an] _N	‘sun-dat+look-rel (= sunflower)’
[jer- <u>é</u> +bat-an] _N	‘earth-dat+sink-rel (= place name)’
[ser- <u>dén</u> +g ^j etʃ-ti] _N	‘suicide squad’
[unút-ma+ben-i] _N	‘forget-neg+I-acc (= forgetmenot)’

(257) Possessive suffixes (level 3)

Compounds containing possessive suffixes

[e ^l -i+atʃuk] _{Adj}	‘hand-3sg.poss+open (= generous)’
[baʃ- <u>u</u> +bozúk] _{Adj}	‘head-3sg.poss+spoiled (= civilian)’
[suurt- <u>u</u> +pek ^j] _{Adj}	‘back-3sg.poss+strong (= heavily clothed)’

(258) Professional -CI suffix

Compounds containing -CI suffix

[hastá+bak-u-d₃u]_N 'patient+look-?-prof (= nurse)'

(259) Derivational suffix -IIk

Compounds containing -IIk

[søz+bir-l^ji-i]_N 'word+one-ness-poss (= unity)'

Since compounding can apply to forms of level 4 (nouns with case suffixes), the daughter node of the compounding construction cannot be specified to be of a level lower than 4.

Let us assume it is specified as level 4. Now, suffixes may be attached to compounds

(240)-(244):

(260) Past tense suffix -DI (level 2)

-DI suffix outside compound

[orhán+bej]-di 'it was Mr. Orhan'

[báf+bak-an]-du 'head+look-rel-past (=it was the prime minister)'

(261) Case endings (level 4)

Case suffixes outside compounds:

[báf+ bak-an]-u 'prime minister-acc

[[vaní+k^jøj]+d₃adde-si]-nden 'Vaniköy street-abl'

[orta+okul]-a 'middle school-dat'

(262) Possessive suffixes (level 3)

Possessive suffixes outside compounds

[<u>ón</u> +søz]-y	‘foreword-1sg.poss’
[ortá-okul]- <u>um</u>	‘my middle school’

(263) Professional -CI suffix

-CI suffix outside compounds

[kuru+jemiſ]-tſi	‘dried fruit-agt (= dried fruit seller)’
[kuru+kahve]-dʒi	‘dried coffee seller’

(264) Derivational suffix -llk

-llk outside of compounds

[báſ+ bak-an]- <u>llk</u>	‘prime minister-ness’
[baba+anne]-l ⁱ ik ⁱ	‘paternal grandmother-ness’

We can conclude from the data in (240)-(244) that the mother node of the compounding construction is level 1.

The last example of the loop has to do with a second set of tense suffixes. Inkelas and Orgun erroneously assigned all tense suffixes to the same level. However, there are in fact systematic differences between the tense/aspect suffixes I have assigned to level 1 (section 4.4) and the ones that cause my next piece of evidence for looping. Ultimately, I will argue that the two sets of tense suffixes are indeed the same, but a predicative suffix precedes the second set. It is this predicative suffix that causes the loop.

The difference between the two sets of tense suffixes are: i) the first set is stress-neutral (not perturbing default final word stress), while the second set is prestressing, and ii) the second set has an extra [j] following vowel-final stems. These differences are illustrated in (265) and (266), where the first set of tense suffixes attaches to verbal predicates (265), and the second set to nominal and adjectival predicates (note that, in the last example in (265), the prestressing second person plural suffix causes stress to be placed on the evidential suffix. All tense/aspect suffixes take this allomorph of the agreement suffix, except for the past tense suffix, which takes the other, stress-neutral allomorph. See Lewis 1967, Underhill 1976 for details of the different agreement paradigms and their distribution):

(265) Verbal predicates: Set 1

g ^j el ^j -dí	‘come-past’
g ^j el ^j -di-níz	‘come-past-2pl’
g ^j el ^j -míʃ	‘come-evid’
g ^j el ^j -míʃ-iniz	‘come-evid-2pl’
di ^l je-dí	‘wish-past’
di ^l je-di-níz	‘wish-past-2pl’
di ^l je-míʃ	‘wish-evid’
di ^l je-míʃ-iniz	‘wish-evid-2pl’

(266) Nominal/adjectival predicates: Set 2

k ^j él ^j -di	‘bald-past’
k ^j él ^j -di-niz	‘bald-past-2pl’
k ^j él ^j -míʃ	‘bald-evid’
k ^j él ^j -míʃ-iniz	‘bald-evid-2pl’
ebé-jdi	‘midwife-past’

ebé-jdi-niz 'midwife-past-2pl'
 ebé-jmif 'midwife-evid'
 ebé-jmif-iniz 'midwife-evid-2pl'

The two sets of tense/aspect suffixes can co-occur. On verbal predicates, Set 1 tense/aspect suffixes can cooccur with Set 2 tense suffixes, resulting in a perfect form (267):

(267) g ^j el ^j -edʒék ^j ₁ -ti ₂	'come-fut-past'
g ^j el ^j -ijor ₁ -du ₂	'come-prog-past' ⁴⁶
g ^j el ^j -dí ₁ -jdi ₂	'come-past-past'
g ^j el ^j -mif ₁ -ti ₂	'come-evid-past'
g ^j el ^j -edʒék ^j ₁ -mif ₂	'come-fut-evid'
g ^j el ^j -ijor ₁ -muf ₂	'come-prog-evid'
g ^j el ^j -mif ₁ -mif ₂	'come-evid-evid'

Nominal predicates do not combine with Set 1 tense/aspect suffixes at all. As a result, they may not be used with two tense suffixes.

Inspection of the data in (267) shows that at least two suffixes appear to be able to occur in either set. The past tense suffix *-di* and the evidential suffix *-mif* can occur in Set 1, where they are stress-neutral and attach directly to vowel-final roots, and also in Set 2, where they are prestressing and appear with an extra [j] after vowel-final stems. It turns out that this very same alternation is exhibited by the conditional suffix *-se* (268), as well:

⁴⁶ The progressive suffix has a fixed stress on its first syllable.

(268) a) Conditional *-se* as group 1 suffix

g ^j el ^j -sé	‘come-cond’
g ^j el ^j -se-níz	‘come-cond-2pl’
g ^j el ^j -sé-jdi	‘come-cond-past’
g ^j el ^j -sé-jmif	‘come-cond-evid’

b) Conditional *-se* as group 2 suffix

g ^j el ^j -edzék ^j -se	‘come-fut-cond’
g ^j el ^j -ijor-sa	‘come-prog-cond’
g ^j el ^j -dí-jse	‘come-past-cond’
g ^j el ^j -mif-se	‘come-past-evid’

c) Conditional *-se* attaching to nominal/adjectival predicates

k ^j él ^j -se	‘bald-cond’
ebé-jse	‘midwife-cond’

So far, we have the following list of group 1 and 2 suffixes (269):

(269) Group 1		Group 2	
-di	‘past’	-(j)di	‘past’
-mif	‘evid’	-(j)mif	‘evid’
-se	‘cond’	-(j)se	‘cond’
-ijor	‘prog’		
-edzek ^j	‘fut’		

It cannot be treated as an accidental fact that the semantic and phonological properties of corresponding group 1 and 2 suffixes are very similar, and where there is a phonological difference, this difference is found for all suffixes that belong to both groups. This strongly suggests that the extra [j] is a separate morpheme, a pre-stressing one, which

appears as [j] after vowel-final stems but is segmentally null following a consonant. (For additional synchronic and diachronic evidence for this morpheme, see Orgun 1993, Orgun 1994a). This suffix, which I will refer to as *J*, attaches to stems bearing group 1 tense/aspect suffixes. The sister of *J* is therefore level 2, which is the level of the mother of tense/aspect suffixes. Since tense suffixes may in turn attach to the mother node of this morpheme, we conclude that the mother is level 1, the level required for the daughter of the tense/aspect constructions. Thus, *J* presents another example of a suffix-driven loop. We have seen examples of suffix-driven loops as well as loops caused by nonaffixal constructions (namely, the Sezer place name construction and compounding).

4.7.4 Clustering

In this section, I will address the last remaining stipulation of level ordering theory. In the standard Lexical Phonology model, every morphological construction that belongs to a given level must be associated with the same phonological system. In Sign-Based Morphology, different phonological systems are modeled by different cophonologies, that is, different phonological mappings (φ) in different constructions. Given that, it follows that morphemes that form a flat structure must all share the same phonological system. However, there is no similar expectation for morphemes that form a hierarchical structure. In such a configuration, there is no principled reason why all constructions with a given level value must also subscribe to the same cophonology (φ).

In this section, I demonstrate the arbitrariness of the decision in Lexical Phonology to choose between two ways of handling morpheme specific phonology. One

way to handle such phonology is to assign the morpheme in question to a particular lexical stratum, and associate the appropriate phonology with that stratum. Another way is to use minor rules or exception features.

For example, I have shown that some Turkish suffixes trigger intervocalic velar deletion, while others do not. I have used this contrast to motivate two separate lexical strata. Consider another case of morpheme-sensitive phonology. The diminutive suffix *-dzik^j ~ -dzuk* triggers deletion of a preceding [k] (270a). This is the only case of nonintervocalic velar deletion in Turkish. In (270b), we see that other consonants are not deleted before this suffix:

(270)	a)	bebek ^j	bebedzik ^j	‘baby’
		k ^j øpek ^j	k ^j øpedzik ^j	‘dog’
		efek ^j	efedzik ^j	‘donkey’
		inek ^j	inedzik ^j	‘cow’
b)	k ^j edi	k ^j edidzik ^j	‘cat’	
	ajur	ajurdzuk	‘bear’	
	k ^j il ^j it	k ^j il ^j ittsik ^j	‘lock’	
	k ^j itap	k ^j itapt ^j uk	‘book’	
	paspas	paspast ^j uk	‘mat’	
	k ^j iraz	k ^j irazdzuk	‘cherry’	
	hamam	hamamdzuk	‘bath’	
	kazan	kazandzuk	‘cauldron’	
	biber	biberdzik ^j	‘pepper’	
	k ^j evg ^j ir	k ^j evg ^j irdzik ^j	‘colander’	
	subaj	subajdzuk	‘army officer’	

By our methodology that each cophonology defines a level, this suffix would be assigned to a separate level. Note, however, that this is the only suffix that is associated with this

preconsonantal k-deleting cophology. The common practice in Lexical Phonology is not to assign such morphemes to separate levels. Rather, a morphologically conditioned phonological rule would be posited to apply within a level (271):

$$(271) \quad k \rightarrow \emptyset / _ + \{\text{diminutive suffix}\}$$

But of course, phenomena that are customarily handled by level ordering could also be handled by morphologically sensitive rules of this sort. For example, instead of positing two lexical strata associated with the intervocalic velar deleting and velar preserving cophologies, we could have written a rule like the one in (272):

$$(272) \quad k \rightarrow \emptyset \quad V _ + \left\{ \begin{array}{l} \text{possessive suffixes} \\ \text{case suffixes} \\ \text{agreement suffixes} \end{array} \right\}$$

Given that the minor rule mechanism, used in Lexical Phonology to deal with some morphologically sensitive phonology, has the power to deal with *all* morphologically sensitive phonology, the stipulation that each level has its own defining phonological system is devoid of empirical content. If two affixes belong to the same level but are associated with different phonological systems, all that one needs to do is formulate enough morphologically conditioned phonological rules.

In Sign-Based Morphology, cophologies are the *only* way in which morphologically sensitive phonology can be handled. In this context, examples such as the Turkish diminutive suffix in (270) are sufficient to demonstrate that the expected (according to level ordering) clustering of levels and cophologies does not hold. While

this might at first seem to be a weakening of the predictive power of the theory with respect to Lexical Phonology, I have argued here that the empirical content of the Lexical Phonology claim is canceled by mechanisms such as minor rules and exception features. The necessity for these mechanisms is enough to show that the strict clustering claim does not hold to begin with. Sign-Based Morphology is thus in a better position to handle attested phenomena without stipulating ad-hoc mechanisms. The cophology that a morphological construction subscribes to does not depend on the level of the construction.

4.8 General evaluation of level ordering

Level ordering, and its structural equivalent, the Strict Layer Hypothesis both make the same claim about morphological structure: a node of level i may dominate a node of level i (as in the Mandarin compounding example), or a node of level $i-1$ (as in most of the Turkish examples). Any other relation between the level of a mother node and a daughter node is a violation of these principles. Example (273) shows the range of possibilities we have found in our survey of Mandarin, Turkish, and Nimboran:

(273)	[level <i>i</i>] [level <i>i</i>]	Mandarin compounding
	[level <i>i</i>] [level <i>i-1</i>]	Turkish suffixation, Nimborean suffixation
	[level <i>i</i>] [level <i>i-j</i>]	Turkish level economy, Nimborean “level skipping” suffixes
	[level <i>i</i>] [level <i>i+j</i>]	Turkish “loop” suffixes, compounding, place name formation

Clearly, every type of relationship between daughter and mother nodes that is logically possible is attested. I conclude therefore that level ordering is not defensible, although the concept of “levels” is still useful for linking up morphological constructions with cophonologies.

I take this demonstration that level ordering does not hold to show Sign-Based Morphology to be superior to approaches such as Lexical Phonology. Given the basic structure of Sign-Based Morphology, level ordering is not the expected state of affairs. If we decide to use a diacritic feature, which I have called LEVEL since it captures traditional level ordering effects, there is no reason to expect for there to be universal restrictions on the relationship of this feature in a mother node and a daughter node. The fact that all logically possible configurations of mother and daughter node levels supports this view of levels over the temporal Lexical Phonology one. In that model, any departure from strict

ordering calls for an additional mechanism such as level jumping or the loop. Allowing these mechanisms amounts to giving up level ordering. A theory that does not incorporate level ordering to begin with is superior, because it does not need to postulate additional tools to handle violations of the now-nonexistent principle of strict ordering.

I will continue the level feature as a convenient diacritic to keep track of attachment requirements of morphemes. However, strictly speaking, there is no need for this feature once we give up level ordering. Selectional requirements of individual affixes should be sufficient to handle all the combinatorial restrictions. As the focus of this study is the interaction of phonology with morphology, rather than morphology itself, I will not attempt such an analysis here, and will continue the feature LEVEL as a convenient, if not transparently named, diacritic to handle distributions of affixes.

Chapter 5. Reference to lexical types

5.1 Introduction

Whether there are limits on the amount of morphological information that phonology is allowed to access, and, if so, what the limits are, has been the topic of much debate in the past decades. In the earliest cyclic approaches to phonology (Chomsky et al. 1956, Chomsky and Halle 1968), the erasure of internal morphological boundary symbols at the end of each cycle (Bracket Erasure) was used as a mechanism that drove the cyclic derivation. Little emphasis was placed at that time on restricting reference by the phonology to morphological information. In fact, the constituent structure tree was assumed to be intact, making possible global reference to previous stages of the derivation.

The observation that information from inner cycles is not accessed by the phonology of outer cycles (Siegel 1974, 1978, Allen 1978) formed one of the original motivations for the framework of Lexical Phonology, starting with Pesetsky 1979 and crystallized in Kiparsky 1982, Mohanan 1982, 1986. The exact formulation of Bracket Erasure has been controversial, and various modifications have been proposed.

With the current trend toward noncyclic phonological analyses, the issue of limiting phonological access to internal morphological structure has been more or less abandoned. Work in Optimality Theory (Prince and Smolensky 1993), for example, has had no reservations about making all morphological information available to all phonology. Now that Optimality Theory has developed in considerable detail, and a more

or less direct approach to cyclic phonological effects is being actively pursued within the Optimality Theory tradition (Orgun 1994b, Orgun 1995a, Benua 1995, Kenstowicz 1995, McCarthy 1996), it may be profitable to reconsider the status of Bracket Erasure effects in the phonology-morphology effects.

This chapter takes up the important issue of Bracket Erasure effects, arguing not only that Sign-Based Morphology captures them as an automatic consequence of the theory, but also that Sign-Based Morphology makes the novel, and correct, prediction that phonology and morphology will exhibit different degrees of sensitivity to internal morphological structure. In particular, it follows from the architecture of Sign-Based Morphology that phonology may only access the immediate constituents of the node it is applying to, while morphology can indirectly refer to information about the “granddaughters” of the top node (that is, to the immediate constituents of the immediate constituents of the top node). Effectively, morphology can see one level deeper than phonology. Much of this chapter will be devoted to demonstrating that this new prediction is supported by data, some of which have been presented as evidence against Bracket Erasure in the past literature, and some of which is introduced here for the first time. By allowing just the right amount of information to be visible to the morphology and the phonology, Sign-Based Morphology makes possible a strict approach to Bracket Erasure that has proved elusive in other approaches.

I therefore conclude that there is still a place for Bracket Erasure effects in modern phonological theory, and that approaches (such as, for example, the Generalized Alignment framework of McCarthy and Prince (1993), the “constraint domains” approach

of Buckley (1996) and the current syntagmatic accounts of cyclic phonological effects enriched by transderivational identity proposed by Benua 1995, Kenstowicz 1995, and McCarthy 1996) that allow unlimited reference to internal morphological structure should be treated with skepticism. To the extent that Bracket Erasure effects seem to hold, more restrictive approaches such as Sign-Based Morphology and the loosely paradigmatic approach of Burzio (1994) are preferable.⁴⁷

5.2 Reasons to revive Bracket Erasure

The most obvious reason to revive Bracket Erasure effects is the never-ending quest for a restrictive theory of grammar. Current work in the phonology-morphology interface has not paid much attention to Bracket Erasure (Hammond 1991, Goldsmith 1993, Karttunen 1993, Lakoff 1993, McCarthy and Prince 1993, Hyman 1994, Kennedy 1994, Kenstowicz 1995, Benua 1996, Buckley 1996). However, the question of Bracket Erasure holds a treasure trove of interesting linguistic facts to be uncovered.

5.2.1 Illustration of Bracket Erasure

A quick example illustrates how Bracket Erasure gives rise to a more restrictive theory, and is therefore not to be abandoned without careful consideration. The example has to do with stress-perturbing suffixes in Turkish (Sezer 1981b, Barker 1989, Inkelas 1994, Inkelas and Orgun 1996). After presenting the range of stress-perturbing behavior, I

⁴⁷ Note that the only difference between the loosely paradigmatic approach and the transderivational approach is that the latter allows global reference to underlying forms. Since this tool has never been crucially used, it is reasonable to suspect that it may be unnecessary. The transderivational identity approach then becomes identical

illustrate how a theory without Bracket Erasure can, by minor modifications of the Turkish stress system, predict the existence of certain types of stress behavior never attested in languages. I conclude that a theory without Bracket Erasure is unprincipled.

In the bulk of the Turkish lexicon, stress is word final. Monomorphemic words with final stress are shown in (274):

(274)	adám	‘man’
	bebék ^j	‘baby’
	dymbelék ^j	‘drum’
	eník ^j	‘pup’
	fera:gát	‘withdrawal’
	gani:mét	‘booty’
	hemfi:ré	‘nurse’
	il ^j ík ^j	‘marrow’
	kaduún	‘woman’

Many suffixes are stress-neutral—they do not interfere with the assignment of default word stress. Stress is final in words containing those suffixes (275):

(275)	a)	év	‘house’
		ev-l ^j ér	‘house-pl’
		ev-l ^j er-ím	‘house-pl-1sg.poss’
		ev-l ^j er-im-dé	‘house-pl-1sg.poss-loc’
		ev-l ^j er-im-de-k ^j í	‘house-pl-1sg.poss-loc-rel’
	b)	g ^j edzik ^j	‘be late’
		g ^j edzik ^j -tír	‘be late-caus’
		g ^j edzik ^j -tir-il ^j	‘be late-caus-pass’
		g ^j edzik ^j -tir-il ^j -ír	‘be late-caus-pass-imprf’
		g ^j edzik ^j -tir-il ^j -ir-l ^j ér	‘be late-caus-pass-imprf-3pl.sbj’

to the loosely paradigmatic approach, which in turn is quite similar to Sign-Based Morphology.

Although stress is usually final, there are several sources of non-final stress. We will not be concerned with two of these: place names and foreign names have a particular pattern of non-final stress (Sezer 1981b, Inkelas 1994, Inkelas and Orgun 1996) (276a). I have already discussed this stress pattern in section 4.7.3. There are also some lexical entries with idiosyncratic non-final stress (276b) (Inkelas 1994, Inkelas and Orgun 1996):

(276) a)	istánbul	‘Istanbul’
	adána	‘Adana’
	ánkara	‘Ankara’
	antál’ja	‘Antalya’
b)	pendzére	‘window’
	tendzére	‘pot’
	tarhána	‘curd’
	zónguldak	‘Zonguldak (place name)’ ⁴⁸

The type of stress-perturbing behavior we are interested in is exhibited by certain affixes. There are two kinds of stress-perturbing affixes: some are prestressing, putting stress on the last syllable of the stem they attach to (277a). Others are self-stressing (277b). They have stress on their first syllable (affixes of this type are always polysyllabic. See Inkelas 1994, McCarthy 1996a for a discussion of the significance of this point).

⁴⁸ *Zonguldak* is one of several place names that have idiosyncratic non-Sezer stress. Other examples are: *kastámonu* (**kastamónu*), *ysk’ýdar* (**ýsk’ýdar*).

(277) a) Prestressing suffixes

i)	-me	‘negative’
	g ^j etír	‘bring’
	g ^j etír-me	‘bring-neg’
	g ^j etír-me-di	‘bring-neg-past’
ii)	-(j)lE	‘comitative’
	k ^j itáp	‘book’
	k ^j itáp-la	‘book-com’
iii)	-l ^m	‘1st person singular subject’
	uzún	‘tall’
	uzún-um	‘tall-1 sg.sbj’

b) Self-stressing suffixes

i)	-i ^j or	‘progressive’
	g ^j etir-í ^j or	‘bring-prog’
ii)	-ErEk	‘adverbial’
	g ^j etir-érek ^j	‘bring-adv’

We are primarily interested in prestressing suffixes (277a). Notice that all of these place stress on the syllable that immediately precedes them. When they are added to a complex stem containing a number of stress-neutral suffixes, the last syllable of this whole stem bears word stress (278):

- (278) g^jedzik^j-me ‘be late-neg’
 g^jedzik^j-tír-me ‘be late-caus-neg’
 g^jedzik^j-tír-il^j-me ‘be late-caus-pass-neg’

Consider a minor variation of the Turkish stress pattern. Imagine a language that puts stress on the root final syllable whenever a stress-perturbing suffix is added to a word, regardless of intervening suffixes (279):

(279) Hypothetical data

a) All neutral suffixes

g^jedzik^j-tír-il^j

b) Stress-perturbing suffix following neutral suffixes

gedzik^j-tír-il^j-ir

This kind of stress behavior is never attested in cyclic phonology. Yet a theory without Bracket Erasure can describe this pattern quite easily, by, for example, using an alignment constraint that refers to the first morpheme boundary in the stem that a stress-perturbing suffix attaches to. Since phenomena like this are not found in languages, we must be suspicious of a theory without some kind of Bracket Erasure mechanism.

5.2.2 Challenges to Bracket Erasure

A number of cases have been cited in the literature as challenges to Bracket Erasure. I examine some representative cases in detail in the following sections. In this section, I show one example to illustrate the general problem. In section 5.2.3, I present some

background information on the theory of lexical types that provides the basic tool for dealing with apparent challenges to Bracket Erasure in Sign-Based Morphology.

One type of challenge to Bracket Erasure that is frequently cited in the literature involves POTENTIATION (Hammond 1991). The term potentiation refers to cases where an affix attaches to bases containing another affix, suggesting that the internal morphological structure of the stem is visible to the outer affix. For example, Bochner 1993 observes that the English suffix *-ment* is only marginally productive in the general lexicon. However, it attaches quite freely to verbs containing the prefix *en-* (280):

(280)	entomb	entombment	enforce	enforcement
	embalm	embalmment	enfranchise	enfranchisement
	embarrass	embarrassment	engage	engagement
	embellish	embellishment	engross	engrossment
	embezzle	embezzlement	enhance	enhancement
	emboss	embossment	enjoy	enjoyment
	embrace	embracement	enlarge	enlargement
	embroil	embroilment	enlighten	enlightenment
	employ	employment	enrich	enrichment
	enact	enactment	enroll	enrollment
	encamp	encampment	enslave	enslavement
	encircle	encirclement	entail	entailment
	encompass	encompassment	entangle	entanglement
	encourage	encouragement	enthrall	enthrallment
	encroach	encroachment	enthrone	enthronement
	endorse	endorsement	entrance	entrancement
	enfeeble	enfeeblement	entrap	entrapment

How can a theory that adopts Bracket Erasure deal with data like this? The main observation that leads to my account is that cases like this require knowledge of the fact that a given *morpheme* is present in a stem, but no knowledge of the *location* of that morpheme within the base is needed.

5.2.3 Types

In this section, I introduce the tools necessary to deal with apparent violations of Bracket Erasure such as the one presented above in section 5.2.2. The tool that leads to a satisfactory analysis of such phenomena is type hierarchies. Type hierarchies form a central part of theories such as HPSG quite independently of Sign-Based Morphology's use of them to deal with challenged to Bracket Erasure. Thus, there is no need to stipulate an ad-hoc mechanism to deal with the data in Sign-Based Morphology. In Sign-Based Morphology, as in HPSG, grammatical constructions are organized into a hierarchy of types such that more specific constructions inherit information from more general ones (see Flickinger et al. 1985, Pollard and Sag 1987, Carpenter 1992 for discussion of types, and Flickinger 1987, Ackerman and LeSourd 1993, Koenig and Jurafsky 1994, Riehemann 1994, Orgun 1995c for application to morphology). One of the basic functions of this hierarchy of types is to capture generalizations across constructions by extracting such generalizations into a supertype. Another function of the type hierarchy is to state which features are appropriate to which kinds of items (for examples, nouns have a CASE feature that verbs do not have), and what range of specifications are possible for the value of a given attribute (for example, *accusative* is a possible value of the attribute CASE, while *potato* is not). Constraints imposed on all items of a given type are also stated as holding on the general type (for example, island constraints can be imposed on a general type that subsumes all constructions that function as islands in a language, such that the subcategorization requirements of constructs of that type must be satisfied

internally). The type hierarchy is represented as a lattice with the maximally general type at the top, and specific types at the bottom.

As an example, I present part of the type hierarchy Koenig and Jurafsky 1994 propose for English (much detail is omitted to make the hierarchy simpler):

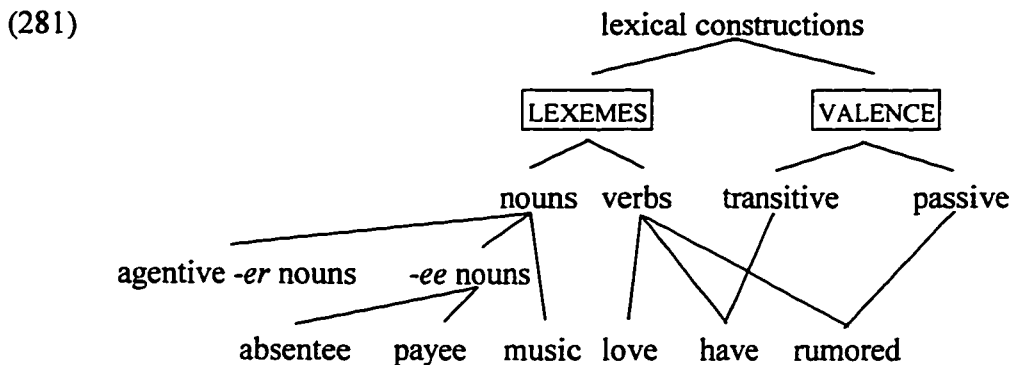

The example in (281) illustrates a number of notational conveniences. The labels LEXEMES and VALENCE describe two “dimensions” in the type hierarchy. Any subtype of the type *lexical constructions* must inherit from a type under LEXEMES as well as a type under VALENCE. This is also referred to as a conjunctive branch, since a specification is needed for each branch under it. Under LEXEMES, we have the types *nouns* and *verbs* (along with, of course, other types that have not been listed). Each subtype must inherit from exactly one of these types. Thus, this kind of node is often referred to as a disjunctive branch. The subtypes of *nouns* identified as *-er nouns* and *-ee nouns* are necessary, because the constructions that add the suffixes *-er* and *-ee* must be described somewhere in the grammar. The definitions of these types accomplishes this task, by including information such as the kind of verb these suffixes attach to and the syntactic, semantic, and phonological properties of the resulting nouns. The constituent structure

representation of the noun *payee* will be something like (282), where the type of each constituent is indicated by a label in italics above the feature specifications:

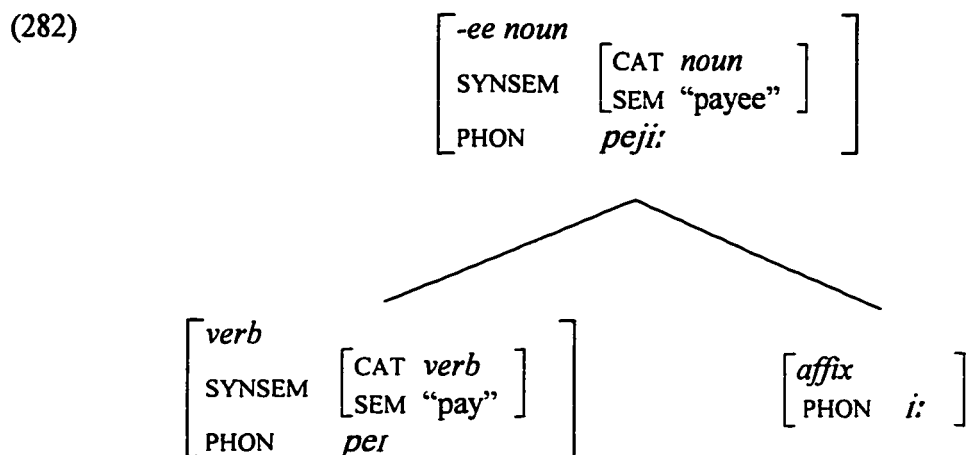

Notice that the mother node of this constituent structure bears the type label *-ee noun*, by virtue of being a construct of English licensed by the *-ee noun* construction. One of the main points of this paper is to show that crucial reference is made by the morphology to these type specifications. This is very fortunate for the theory: by grouping a number of lexical entries into the type *-ee noun*, we are claiming that they form a natural class that we can refer to. We should then expect the grammar to use this information in some fashion, or suspect that there is something wrong with the theory. I will show that not only is it reasonable to suspect that this type information is referred to in the morphology, but that it provides the only principled solution to a number of apparent counterexamples to Bracket Erasure.

5.3 Reference to lexical types in English

In this section, I will present data previously analyzed by Raffelsiefen 1992 concerning zero nominalizations in English. Examination of additional data will reveal interesting consequences for Bracket Erasure.

The construction of interest is what Raffelsiefen calls “stress-shifting nominalization”. Essentially, a disyllabic verb with stress on its second syllable is converted to a noun by placing primary stress on the first syllable and secondary stress on the second syllable. This construction is unproductive, as the data in (283) show. The verbs in (283a) have stress-shifted nominals while those in (283b) do not.

(283)	<u>Verb</u>	<u>Noun</u>	<u>Verb</u>	<u>Noun</u>
	accént	áccènt	accóunt	*áccòunt
	addréss	áddrèss	arrést	*árrèst
	allóy	állòy	allúre	*állùre
	abstrúct	ábstràct	advánce	*ádvànce
	conflíct	cónflict	consént	*cónsènt
	contést	cóntèst	concern	*cóncern
	constrúct	cónstrùct	contról	*cóntròl
	decréase	décrèase	deféat	*défeat
	discárd	díscàrd	disgúst	*dísgust
	discóunt	díscòunt	disdáin	*dísdàin
	expórt	éxpòrt	exháust	*éxhàust
	misprínt	mísprínt	mistrúst	*místrúst
	survéy	súrvèy	surpríse	*súrpríse

Even though this stress-shifting nominalization construction is only marginally productive in general, it does have a “niche of productivity”, as Raffelsiefen notes. Verbs that contain the prefix *re-* freely undergo stress-shifting nominalization (284). Each pair

in (284a), shows a verb root and its counterpart containing the prefix *re-*. Each pair in (284b) shows a *re*-verb and its stress-shifted nominalization.

(284)	<u>Verb</u>	<u>re-verb</u>	<u>re-verb</u>	<u>Noun</u>
	fill	refill	refill	réfill
	do	redó	redó	rédió
	make	remáke	remáke	rémake
	load	relóad	relóad	réload
	paint	repáint	repáint	répaint
	play	repláy	repláy	réplay
	count	recóunt	recóunt	récount
	print	reprint	reprint	réprint
	run	rerún	rerún	rérun
	take	retáke	retáke	rétake

To confirm the productivity of stress-shifting *re*-verb nominalization, I have collected additional data from two native speakers. As expected, all the verbs in (285) have stress-shifted nominalizations.^{49,50,51}

⁴⁹ Hyphens are used to distinguish verbs from near-homophones containing the Latinate suffix *re-* (e.g., *reform* versus *re-form* ‘form again’).

⁵⁰ Some of these forms sound marginal to some speakers. The sets of stress-shifted nouns that are acceptable and marginal varies from speaker to speaker. This does not mean that the construction is unproductive, but rather is caused by the usually constraint on derivational morphology that forms are acceptable to speakers to the extent that they know what meaning to assign to them. This point is taken up again shortly.

⁵¹ The stress-shifted nouns are deverbal rather than derived by adding the prefix *re-* to a deverbal noun ($\text{fill}_V \rightarrow \text{fill}_N \rightarrow \text{refill}_N$). We know this, because the prefix *re-* can in fact be added to noun stems. The resulting word has primary stress on the first syllable of the stem (that is, the syllable following *re-*), as in *recápture*. The deverbal nouns I am examining in this section do not have this stress pattern. Rather, they have the stress pattern of stress shifted denominal verbs such as *súrvèy*, which indicates that they are licensed by the stress shifting deverbal nominalization construction rather than by prefixing *re-* to noun stems.

(285)	rebore	recross	rehash	re-pose	re-cede	repass	retread
	rebound	refit	rejoin	reroute	recast	replant	retrim
	recap	refloat	relay	re-serve	recount	replay	revamp
	rebuild	re-form	reline	reset	regain	restock	rewind
	recharge	refund	remold	resole	reheat	retool	rewire
	re-cite	re-fuse	remount	respray	rehang	retouch	rewrite

Although stress-shifting nominalization applies productively to *re*-verbs, it is subject to a number of restrictions. The first restriction is phonological: stress-shifting nominalization does not apply to verbs that contain more than two syllables (Orgun 1995c). None of the verbs in (286) has a stress-shifted nominalization.

(286)	redistribute	recrudesce	re-enter	reinter	re-cover	reproduce
	reconfigure	recriminate	re-establish	reinterpret	re-create	requicken
	reascend	recycle	re-examine	reinvest	re-emerge	restudy
	reassemble	redecorate	re-export	reissue	re-enact	resurface
	rebaptize	recuperate	refashion	rekindle	reinstale	resurvey
	rebroadcast	redeploy	reforest	remilitarize	reinsure	retranslate
	reforecast	redial	regenerate	remodel	repolish	revaccinate
	repredict	reduplicate	rehabilitate	remonetize	repopulate	revalue
	recalesce	re-echo	reimburse	reoccupy	reunite	repeople
	recapitulate	re-edit	reimport	reorient	revalorize	reinsert
	recapture	re-educate	reignite	reorientate	revisit	re-embark
	recognize	re-elect	reinforce	repaper	revivify	recommit

An Optimality-theoretic analysis of the phonology of this construction that accounts for its inapplicability to polysyllabic verbs can be found in section 5.4.

There is a second class of apparent exceptions. The verbs shown in (287) do not undergo stress-shifting nominalization.

(287)	rĕward	rĕform	rĕport	rĕsign	rĕduce	rĕserve	rĕtort
	rĕceive	rĕfuse	rĕpose	rĕsist	rĕfer	rĕsent	rĕtrace
	rĕcite	rĕgard	rĕpress	rĕsolve	rĕfine	rĕside	rĕtract
	rĕcoil	rĕlate	rĕprove	rĕsort	rĕflect	rĕsign	rĕverse
	rĕcede	rĕlax	rĕpute	rĕsound	rĕpeal	rĕstrain	rĕvert
	rĕcount	rĕmind	rĕquest	rĕspect	rĕpel	rĕstrict	rĕview
	rĕcur	rĕmove	rĕquire	rĕspire	rĕplete	rĕsume	rĕvile
	rĕdeem	rĕnew	rĕsect	rĕstore	rĕply	rĕtain	rĕvise
	rĕvive	rĕvoke	rĕvolve				

What these verbs share is that they all contain the Latinate prefix *re-*, which can be distinguished from the English prefix *re-* by its lax vowel, as well as by semantic considerations (287). We therefore conclude that the “niche of productivity” of stress-shifting nominalization is limited to verbs containing the English prefix *re-*. Thus, we need to refer to the specific morpheme in the stem to determine that *re-*verb nominalization may apply productively.

A third class of exceptions involve semantic reasons, although the exact formulation of the semantic restriction is not clear. My informant rejected stress-shifted nominalizations of the verbs in (288), on the grounds that she could not assign any specific meaning to them.

(288)	rebind
	rename
	repot
	reseat
	re-sign
	retell
	reword

In later elicitations, I have asked two informants (including the original informant who at first rejected the forms in (288)) to imagine a context like: “this didn’t work too well, we’re going to have to do a ...” where a nominalized verb can be inserted. Both informants could use *re*-verb nominalizations of all disyllabic stems, including those in (288), in this context. This shows that the restriction in (288) is indeed a semantic one, one that plagues much derivational morphology—derivational morphology is often only applicable if the resulting form has appropriate semantics, where appropriateness may be defined on the basis of such extralinguistic factors as newsworthiness, commonness, and so on.

In summary, stress-shifting nominalization is unproductive in general. It applies to a seemingly arbitrary class of verbs that do not share any semantic, morphological, or phonological properties. However, there is one class of verbs to which stress-shifting nominalization applies productively, namely disyllabic verbs containing the prefix *re*-. At this point, we must devise an account of this phenomenon. That is, we need a mechanism to let a morphological construction (here, stress-shifting nominalization) to recognize that the stem it applies to contains a specific morpheme (here, the prefix *re*-).

The fact that the nominalization construction needs to refer to the presence of a particular morpheme within the base it applies to may be thought to be evidence against Bracket Erasure. Indeed, Hammond 1991 calls this type of sensitivity to the presence of a specific morpheme in the stem “potentiation” (following Fabb 1988), and proposes to handle it via (criterial) morphemic circumscription. I will illustrate Hammond’s account by considering one example, namely the English suffix *-ion*, which attaches freely to

stems ending in the suffix *-ize* (among others). In Hammond's theory, the word *modernization* is derived as follows:

(289)	UR	modern	
	Suffixation	modernize	
	Circumscription	modern <ize>	(criterion satisfied: <i>-ize</i> present)
	Suffixation	modernization	

In order to recognize that the base ends in the appropriate suffix, we first detach the final morph of the base by morphemic circumscription. Recognizing this suffix as *-ize*, we know that we may attach *-ion*. We reattach *-ize*, and then attach *-ion*. Obviously, this account requires referring to internal morphological structure, and is therefore inconsistent with Bracket Erasure. Let us see how we would use criterial morphemic circumscription to deal with *re-* verb nominalization:

(290)	UR	fill	
	Suffixation	refill	
	Morphemic circumscription	<re> fill	(criterion satisfied: <i>re-</i> present)
	Stress-shifting nominalization	réfill	

These facts pose an apparent challenge to Sign-Based Morphology, which is committed to a strict view of Bracket Erasure effects by virtue of its architecture. I will turn in a moment to ways of dealing with this apparent problem. But first, I will show that the morphemic circumscription account is itself subject to serious problems. Like criterial prosodic circumscription (McCarthy and Prince 1986, 1990, 1994a,b), criterial morphemic circumscription should be expected to target material at the edge where the affix in question is attached. That is, a suffix circumscribes material at the end of the stem,

while a prefix circumscribes material at the beginning.⁵² Although not much has been said about this point, it is clear that such a restriction holds on criterial prosodic circumscription. Thus, we often find cases of prefix allomorphy sensitive to the initial segment of the base, and of suffix allomorphy sensitive to the final segment of the base. A good example is the Turkish passive suffix: the allomorph *-(I)n* is used on vowel and [l]-final roots, while *-n* is used elsewhere (291):

(291) tek ^j mel ^j e-n	‘kick-pass’
buda-n	‘prune-pass’
jyk ^j sel ^j -in	‘raise-pass’
ka-l-un	‘stay-pass’
døn-y ^j	‘turn-pass’
bak-ı-l	‘look-pass’
dolağ-ı-l	‘wander-pass’
bedzer-il ^j	‘manage-pass’

This very common type of allomorphy can be accounted for by using criterial prosodic circumscription: the passive suffix circumscribes the last segment in order to decide on which allomorph to use, then attaches to the whole stem (thus positive or negative circumscription would not be appropriate). If criterial prosodic circumscription is not restricted to the edge of attachment, we predict cases of prefixal allomorphy sensitive to the final segment of the base, and of suffixal allomorphy sensitive to the initial segment of the base. Since such flagrant violations of locality are not found in languages, criterial circumscription must be restricted to the edge of attachment.

⁵² This differs from positive and negative circumscription, where, for example, a foot may

Thus, if morphemic circumscription is the right way to deal with potentiation, we should not find cases where a prefix is potentiated by a suffix (that is, it may attach only to bases that contain that suffix), or a suffix potentiated by a prefix. Unfortunately for the theory of morphemic circumscription, there is a convincing case of a suffix potentiating a prefix in English. The prefix *un-* attaches only to some adjectives:

(292) uncommon *ungood
 unhappy *unpretty

However, *un-* will attach to any adjectival participle derived from a verb by the suffix *-ed* (or *-en*):⁵³

(293) undeserved unmodified unprecedented
 untried unobserved untied
 unmentioned unreinforced unpainted

This shows that edgemostrness is not the relevant criterion for potentiation. Rather, one needs to refer to the outermost morpheme in terms of constituent structure. This could be a prefix, suffix, or an infix (or, for that matter, even a nonaffixational morphological construction such as compounding, reduplication, zero derivation, truncation, etc.). Thus, “morphemic circumscription” is not a matter of linear order, but rather one of hierarchical constituent structure. The morpheme that needs to be identified is the outermost one in the constituent structure, regardless of whether it is a prefix or a suffix.

be circumscribed at the left edge and a suffix attached to this foot.

⁵³ It is possible that an account of this based on lexical semantics may be formulated. The general point remains valid, however. The example involving potentiation of -

Recall from section 5.2.3 that each morphological construction defines a particular type in the lexical type hierarchy. Affixation constructions are of course also part of the type hierarchy. In (294), I repeat Koenig and Jurafsky 1994's type hierarchy, but include the type *re-verb* as well (and omit some irrelevant information):

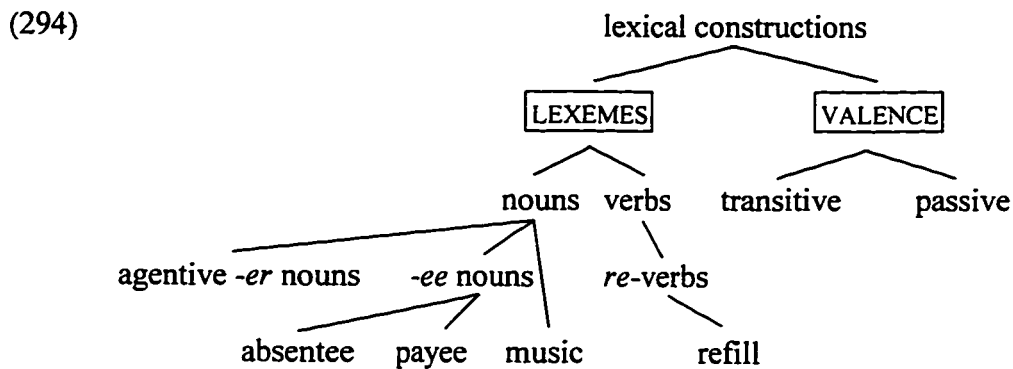

A simplified constituent structure for the verb *refill* is given in (295):

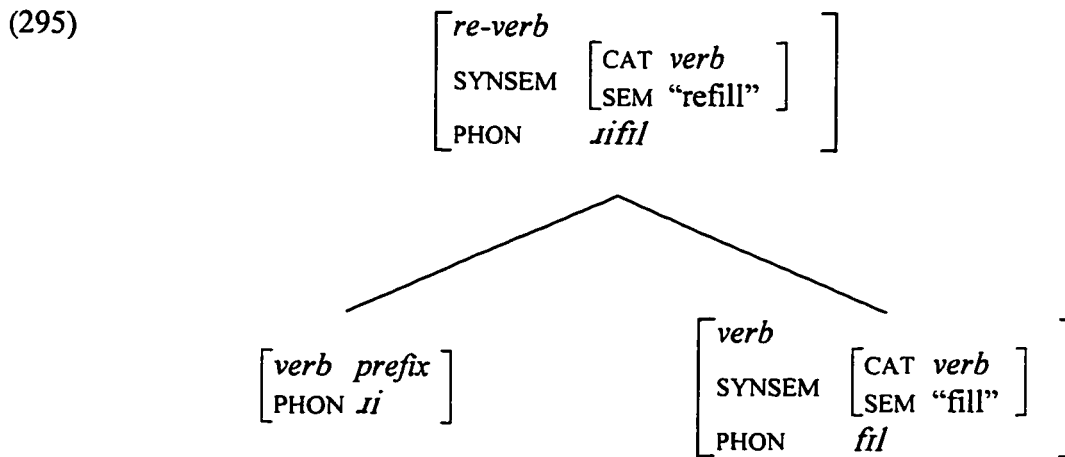

ment by *-en* can also be used to illustrate the same point, since it is another case of wrong-edge circumscription.

I propose that the productive stress-shifting nominalization construction specifies its stem daughter to be a *re-verb*, rather than the more general type *verb*. Thus, the construction looks something like (296):

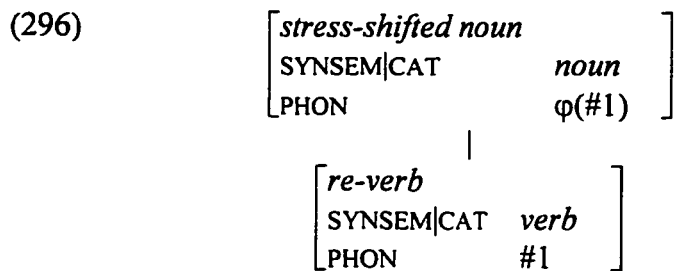

The content of φ has been described in section 5.4. Like all morphological constructions, the stress-shifting nominalization construction makes reference to the type of its daughter. This type reference is sufficient to uniquely identify the outermost (in terms of constituent structure, not linear order) morphological construction that has applied to the daughter. Since the daughter is an affixed stem, this reference amounts to identifying the outermost affix in the stem. For the other cases of potentiation described in this section, a similar account is possible (for example, the construction that adds the prefix *un-* to adjectives will specify its daughter to be a participial adjective by referring to this lexical type). This account has two advantages over morphemic circumscription: first, it is more restrictive. Morphemic circumscription requires abandoning Bracket Erasure and identifying a subpart of the phonological string as a morph. This makes the locations of morph boundaries available. Yet, all we need to deal with potentiation is to know that a particular morpheme is present in a stem. There is never any need to refer to the location of that morpheme within the stem. Sign-Based Morphology makes just the right amount

of information available: the identity of the outermost morpheme is available through reference to the lexical type of the stem. The location of the morpheme is not available, since phonological strings do not carry any morphological breakdown information (this function being taken over entirely by the constituent structure skeleton). The second advantage Sign-Based Morphology offers is that it can identify nonaffixational morphological constructions such as compounding, which circumscription cannot do. We will see examples where reference to nonaffixational constructions is needed in sections 5.5.3 and 5.5.4.

I close this section with a discussion of how to treat unproductive stress-shifted nominals of verbs that do not contain the prefix *re-* (283). Using Koenig and Jurafsky's (1994) "open world" interpretation,⁵⁴ we list all unproductive stress shifted nominals under the type *stress shifted deverbal noun (SSN)*. It is understood that such listing closes the branch; thus this type cannot be used on-line to create new forms. A separate subtype of the type *SSN* is the productive *re-verb* nominalization construction.

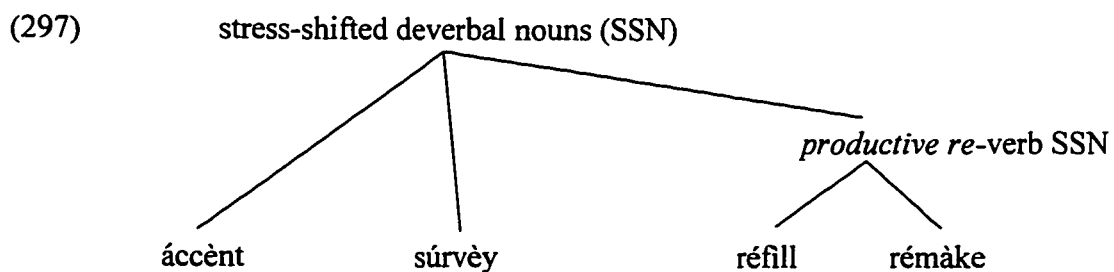

⁵⁴ The advantage of this interpretation is its simplicity—it is consistent with Carpenter's (1992) axiomatization of type hierarchies. Other possible choices are Riehemann's (1994) open world interpretation, or nonmonotonic inheritance with defaults.

No actual words are listed under the productive *re-verb* nominalization construction, which is used on-line for creating or processing novel *re-verb* nominals.

5.4 Phonological analysis of *re-verb* nominalization

The main purpose of this section is to develop a phonological analysis that accounts for the fact that stress-shifting nominalization applies successfully to disyllabic verbs, but fails to apply to longer verbs. The main insight is that ungrammaticality results from two incompatible conditions: first, stress-shifted nominals must have a characteristic stress pattern: initial primary stress and peninitial secondary stress (*rédò*). Second, stress clash is not allowed in forms that contain more than two syllables (in disyllabic forms, stress clash is unavoidable since there are as many stresses as there are syllables).

The phonological restriction to disyllabicity presumably has to do with the foot assignment to stress-shifted nominals (Orgun 1995c, Orgun and Sprouse 1996b). A disyllabic stress-shifted nominal has two monosyllabic feet adjacent to each other):

(298) F F
 ^ ^
 re do

When we attempt to apply stress-shifting nominalization to verbs containing more than two syllables there is no grammatical output. We need to consider two patterns. In the first pattern, the input verb has stress on the syllable immediately following the prefix *re-* (that is, the root initial syllable). In the second pattern, the input verb does not have stress on the root initial syllable, but rather on a syllable further to the right. In this case, the

output form has primary stress on *re-*, while secondary stress is placed on the syllable that bears stress in the input verb in my informant's attempts at pronouncing the ungrammatical forms. In other words, the secondary stress does not shift to its required location (immediately following *re-*) (299):

- | | | |
|-------|-----------|------------------------|
| (299) | *réunite | (not <i>réùnite</i>) |
| | *réemplòy | (not <i>réèmploy</i>) |
| | *récommit | (not <i>récòmmit</i>) |

Whether or not any linguistic significance can be attached to attempted rendering by informants of ungrammatical forms, the data in (299) suggest an analysis couched within Optimality Theory (Prince and Smolensky 1993). In Optimality Theory, a grammar is modeled by a set of ranked and violable constraints. Among an infinite set of candidate outputs, the one that incurs the fewest violations of higher-ranking constraints is picked as the actual output, even if it violates more lower-ranked constraints than competing candidate forms. Handling ungrammaticality in this model is a bit of a challenge—it would appear that Eval, the constraint system, will always pick a winner. Prince and Smolensky 1993 propose that there is a special candidate called the null parse. This candidate is stipulated to violate no constraint except for a new one they propose, *MPARSE*, which no other candidate violates. Now, ranking a phonological constraint *C* above *MPARSE* amounts to declaring *C* to be inviolable: the null parse is better than any candidate that violates *C*. If violation of *C* cannot be avoided, then the null parse emerges as the winner. In other words, there is no grammatical output.

For the English *re-verb* problem, the inviolable constraints responsible for ungrammaticality are the ones that require the special stress patterns of stress-shifted nominals. Here, I will take an informal, convenient approach to constraint descriptions. It should be kept in mind that whatever phonological analysis of the facts is favored, the general points regarding the architecture of grammar will be intact.

The first inviolable constraint is one that Prince and Smolensky 1993 have proposed, $LEX \approx PR$, which requires every output form to contain a foot. The second is an alignment constraint (McCarthy and Prince 1993) that requires each output form to start with a stressed syllable. The third one is a constraint requiring for there to be a secondary stress (2nd Stress). The fourth constraint requires the secondary stress to be adjacent to the primary stress. The constraints are summarized in (300):⁵⁵

- | | | |
|-------|--------------------|---|
| (300) | $LEX \approx PR$ | The output must have a primary stress |
| | 2ND STRESS | The output must have a secondary stress |
| | ALIGN
PRIMARY | ALIGN(Word, L, Primary Stress, L)
The first syllable of the output must bear the primary stress. |
| | ALIGN
SECONDARY | ALIGN(Secondary Stress, L, Primary Stress, R)
The secondary-stressed syllable must be adjacent to the primary-stressed syllable. |

Since none of these constraints is ever violated by the output of the stress-shifting nominalization constraint, we may safely rank them all above $MPARSE$. Of course, talking

⁵⁵ Orgun and Sprouse (1996a,b) propose a more elegant analysis of this phenomenon: they argue that *re-verbs* contain two phonological words, and that each phonological word must have initial stress. Although this analysis is elegant, it does not extend to

about the relative ranking of inviolable constraints is meaningless, since the only evidence for ranking comes from conflict resolution, where the constraint that is violated by the winning candidate is ranked lower. In the case of inviolable constraints, conflict gives rise to ungrammaticality. No resolution is possible. Note therefore that Prince and Smolensky's innovation of MParse is nothing but a handy notation for declaring some constraints to be inviolable. If the constraints in (300) were all the grammar had, then a stress-shifted output would be possible for polysyllabic *re*-verbs (for example, **réùnite* satisfies all the constraints in (300)). The fact that this is impossible suggests that there is yet another inviolable constraint at work. This constraint prevents the input stressed syllable to be destressed to allow the root initial syllable to bear secondary stress. Such a constraint has been used by McCarthy (1995), who calls it HEAD-IDENT (301).

(301) HEAD-IDENT A syllable that is stressed in the input must be stressed in the output as well.

In the tableau in (302), the constraints LEX≈PR and ALIGN-PRIMARY are not shown, since none of the candidates that violate them are of interest to us.

(302)

	2ND STRESS	HEAD-IDENT	ALIGN-2ND	MPARSE
☞ rédò				
rédo	*!			
∅				*!

the general stress-shifted nominalization construction that licenses, for example, *àdrèss*. The more direct analysis here handles *all* stress-shifted nouns.

	2ND STRESS	HEAD-IDENT	ALIGN-2ND	MPARSE
réunite		*!		
réunite			!*	
réunite	*!			
∅				

This account works well for *re*-verbs that have stress later than the second syllable. But how about those that are stressed on the root initial syllable? For those, there is a candidate that satisfies all the constraints we have so far. For example, *révivify* satisfies all our constraints. It seems that clash avoidance is at work in these cases. We might therefore try adding *CLASH as another inviolable constraint to our grammar to rule out these forms. However, this move will not work, since it will incorrectly rule out grammatical stress-shifted nominalizations of disyllabic *re*-verbs (such as *réfill*), which show that *CLASH must be ranked below MPARSE. Orgun and Sprouse (1996a,b) contend that this is a general problem with MPARSE—there are cases where violation of a constraint known to be violable in the language could have led to a grammatical output, but such violation is nonetheless avoided and no grammatical output is possible.⁵⁶ Their proposal is to move all inviolable constraints to a new constraint system called CONTROL. Grammatical output forms must satisfy two conditions: first, they have to be the optimal output picked by EVAL, and, second, they must satisfy all constraints in CONTROL. For the *re*-verb problem, it suffices to assign ALIGN-2ND to CONTROL, and rank *CLASH above HEAD-IDENT. MPARSE is not used in this model. The winning outputs for the three input

⁵⁶ The problem posed to MPARSE by the English stress shifting nominalization construction is quite similar to the problem posed by Turkish minimality in section 2.3. In both cases, repair would be possible by violating a constraint known to be

forms *redo*, *reunite*, and *revivify* picked by EVAL are shown in (303) (the null parse is no longer included in the candidate set):

(303)

EVAL	2ND STRESS	*CLASH	HEAD IDENT
☞ rédò			
rédo	*!		

EVAL	2ND STRESS	*CLASH	HEAD IDENT
☞ réunite			
réùnite		*!	
réunite	*!		

EVAL	2ND STRESS	*CLASH	HEAD IDENT
révivify		*!	
☞ révivify			
révivify	*!		

These winners must be checked against the inviolable constraint component, CONTROL.

This is done in (304):

(304)

CONTROL	ALIGN-2ND
✓ rédò	
✗ réunite	*!
✗ révivify	*!

To sum up the discussion so far, stress-shifting nominalization applies productively to verbs containing the prefix *re-*. Even though there is a large number of polysyllabic verbs that do not undergo stress-shifting nominalization, this is for purely phonological reasons, and therefore casts no doubt on the productivity of the construction.

violable in the language. However, ungrammaticality rather than repair is still the

5.5 Cophonological allomorphy

In this section, I have two goals. The first is to motivate the concept of cophonologies by showing that there is a special types of allomorphy that I call cophonological allomorphy. Most cases of allomorphy are such that the various allomorphs of a morpheme contribute different phonological material. In cophonological allomorphy, the allomorphs have exactly the same underlying phonological shape, but they trigger different morphophonemic alternations, or impose different phonological constraints. My second aim in this section is to show that there are cases of cophonological allomorphy in which crucial reference to the lexical type of the input stem is needed. Some of these cases have been (Japanese, section 5.5.1) or can be (Turkish, section 5.5.3) seen as counterexamples to Bracket Erasure. I show that in these cases, just as in the English case, the correct approach is to make reference to the lexical type, not to morph boundaries, because all that is needed is to recognize the existence of a morpheme within the stem, but no reference is ever made to the location of the morpheme.

5.5.1 Japanese deverbal noun accentuation

Japanese deverbal noun accentuation has been claimed to be a counterexample to Bracket Erasure (Poser 1984). In this section, I show that reference to lexical types is all that is needed to deal with the data, as it is necessary to identify compound verbs, but the location of the compound boundary is never referred to. Furthermore, the data in this section cannot be handled by morphemic circumscription, and thus provide an empirical argument in favor of Sign-Based Morphology.

result.

I start with a description of accentuation of deverbal nouns formed out of noncompound verbs. If the verb is accentless, so is the deverbal noun, as shown in (305):

(305)	Accentless verb (infinitive)		Deverbal noun (no accent)
	kari-ru	‘borrow’	kari
	nagusam-u	‘be diverted by’	nagusami
	utaga-u	‘doubt’	utagai

If the verb is accented, then so is the deverbal noun. However, the deverbal noun bears a final accent regardless of the location of the verb’s accent (306):

(306)	Accented verb (infinitive)		Deverbal noun (final accent)
	haji’-ru	‘be ashamed’	haji’ ‘shame’
	hira’k-u	‘open’	hiraki’ ‘closet’
	i’r-u	‘parch’	iri’

I now present a rough Optimality Theoretic analysis of this behavior. The analysis is presented just for illustrative purposes. Even if a different analysis is adopted, the main points of this section will remain valid.

We need some faithfulness constraints ruling out insertion and deletion of accents (DEP-accent and MAX-accent, respectively), and requiring the accent to fall on the same syllable in the output as it does in the input (ACC-LOC). This last constraint can be seen as a kind of “head-identity” constraint (McCarthy 1996a) which requires the correspondent of an accented syllable to be accented, and the correspondent of an accentless syllable to

be accentless. We also need an alignment constraint that requires any accent in the output to be final. The constraints for deverbal noun formation are summarized in (307):

- (307) MAX-accent Every input accent must correspond to an output accent.
- DEP-accent Every output accent must correspond to an input accent.
- ACC-LOC An accented input syllable must correspond to an accented output syllable. An accentless input syllable must correspond to an accentless output syllable.
- ALIGN(accent, R, word, R) The accent (if any) in the output must be final

Of these constraints, ALIGN and MAX must dominate ACC-LOC. No other ranking is motivated by the data. The tableaux in (308) show how these constraints account for the data (DEP is not shown in the tableaux; it is never violated):

(308)

/kari/	MAX-accent	ALIGN	ACC-LOC
☞ kari			

/i'ri/	MAX-accent	ALIGN	ACC-LOC
iri	*!		
i'ri		*!	
☞ iri'			

I will refer to this particular constraint ranking as φ_1 in constructions.

In contrast with what we have just seen, deverbal nouns formed out of compound verbs are never accented, even when the compound verb itself is accented (309):

(309)	Compound verb (infinitive)	Deverbal noun (no accent)
	hiki-age'ru 'pull up'	hikiage
	ii-a'u 'quarrel'	ii <i>ai</i>
	oki-kae'ru 'replace'	okikaeri

Poser argues that there is an accentuation rule that mentions the compound boundary in its environment. This requires the compound boundary to be visible to the phonology, a violation of Bracket Erasure. We would like to develop an alternative analysis to preserve our strict approach to Bracket Erasure effects. Note that, quite independently of our desire for a restrictive theory, there is good motivation to look for an alternative analysis: a rule that deletes an accent when there is a morpheme boundary anywhere in the form is highly unnatural, and is inconsistent with any locality conditions that one might want to impose on phonological rules (Poser 1982, Odden 1994).

The cophonology enforcing accent deletion will have a high-ranking constraint NO-ACCENT. I show no tableaux to illustrate this cophonology, since it is very straightforward: NO-ACCENT ranks higher than MAX, forcing any input accent to be deleted. I will call this cophonology φ_2 .

The solution I propose to Poser's problem involves reference to lexical types. Any grammar that has a compounding construction must have a node in the type hierarchy that describes this construction. For example, the partial type hierarchy that Riehemann 1994

proposes for German includes the types *compound* and *derived*,⁵⁷ as shown in the diagram in (310):

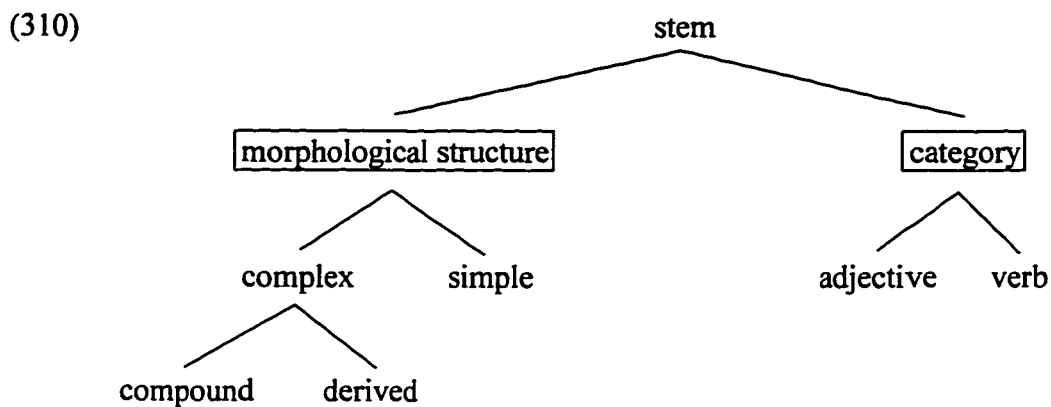

The lexical type hierarchy for Japanese will also contain similar types. The type that we need to refer to is *compound verb*, shown in (311) to inherit from the types *compound* and *verb*:

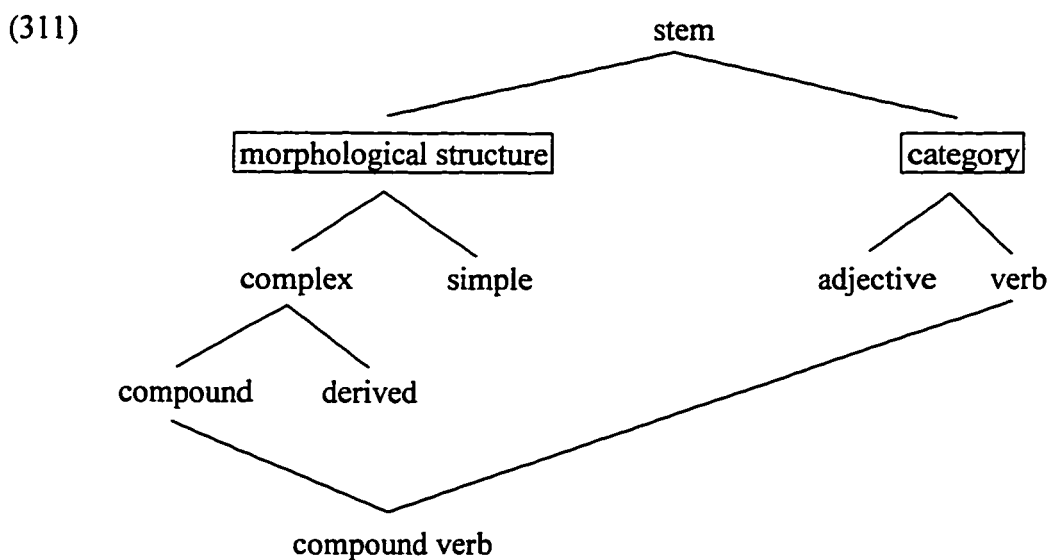

⁵⁷ The type *derived* is intended to include affixed forms as well as those derived by nonconcatenative morphology such as zero derivation, reduplication, and truncation. There will be a subtype for each of these kinds of derivation, of course.

The Japanese deverbal noun construction has two “alloconstructions” (I would have called them allomorphs, but since we are not dealing with a morpheme, but rather a construction, I use the term alloconstruction). The general construction is called *deverbal noun*. This construction does not specify the phonological mapping. It has two subtypes, which are the two alloconstructions. One of these alloconstructions applies to noncompound verbs and subscribes to φ_1 . The other alloconstruction, which applies to compound verbs subscribes to φ_2 , the accent deleting cophonology (312).

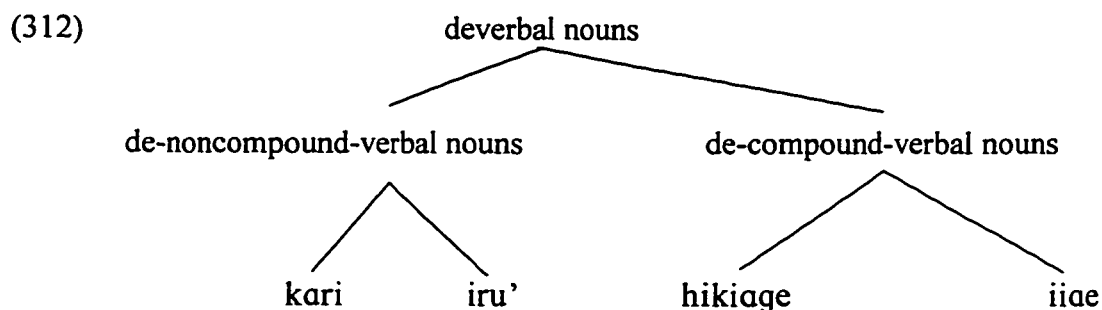

The description of the type *deverbal noun* is shown in (313):

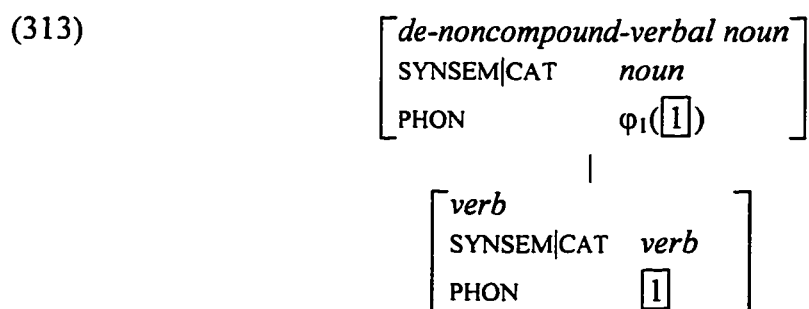

The structure of de-compound-verbal nouns is shown in (314):

(314)

$$\begin{array}{c}
 \left[\begin{array}{ll}
 \textit{deverbal noun} & \\
 \text{SYNSEM|CAT} & \textit{noun} \\
 \text{PHON} & \varphi_2(\boxed{1})
 \end{array} \right] \\
 | \\
 \left[\begin{array}{ll}
 \textit{compound verb} & \\
 \text{SYNSEM|CAT} & \textit{verb} \\
 \text{PHON} & \boxed{1}
 \end{array} \right]
 \end{array}$$

We have seen that there is no Bracket Erasure problem in Japanese deverbal noun accentuation. All we need to refer to is the lexical type of the input verb. The lexical type is available and needed for constructing the type hierarchy independently of Bracket Erasure effects. No additional ad-hoc tools or mechanisms are necessary.

Note also that morphemic circumscription cannot deal with Japanese deverbal noun accentuation. If we circumscribe a morpheme, we end up with a regular stem, which should be subject to the usual accentuation rules. This is the wrong result. Thus, we have seen that Sign-Based Morphology is not only more principled than morphemic circumscription in that it makes less information available, it also possesses the required descriptive flexibility that morphemic circumscription lacks.

5.5.2 Breton mutation

The second example of cophonological allomorphy comes from Breton, and involves the definite article *ar*, which I will treat as a clitic. The data come from Press 1986 and Stump 1988. When *ar* is added to feminine singular or masculine plural human nouns, mutation applies. In all other cases, mutation does not apply. Example (315) shows the alternations imposed by mutation.

(315)	p	t	k	b	d	g	gw	m
	↓	↓	↓	↓	↓	↓	↓	↓
	b	d	g	v	z	x	w	v

In (316), we see lenition applying to feminine singular and masculine plural human nouns, while in (317), lenition fails to apply.

(316)	a)	ar vag	‘the boat (fem sg)’	(bag)
	b)	ar baotred	‘the boys (masc pl human)’	(paotred)
	c)	ar vrex	‘the arm (fem sg)’	(brex)
	d)	ar werenn	‘the glass’ (fem sg)’	(gwerenn)

(317)	a)	ar bagu	‘the boats (fem pl)’	(bagu)
	b)	ar paotr	‘the boy (masc sg)’	(paotr)
	c)	ar penn	‘the head (masc pl non-hum)’	(penn)

In an SPE-like framework, lenition might be expressed as a morphologically conditioned phonological rule, along the lines of (318):

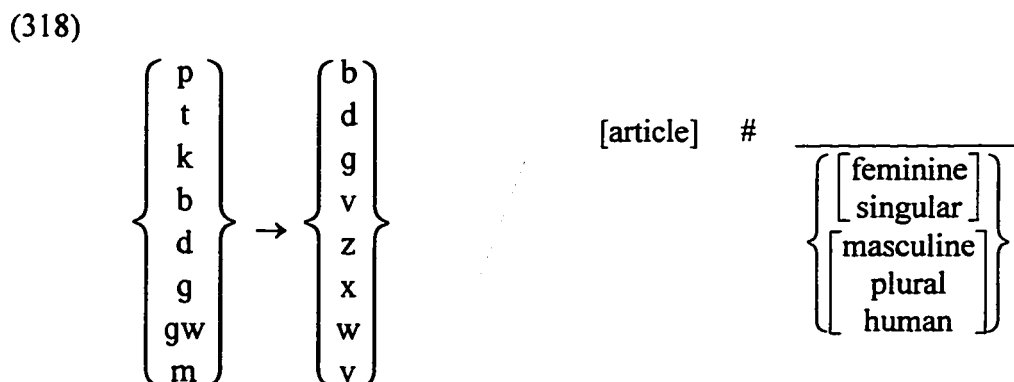

In a framework such as Sign-Based Morphology that uses cophonologies, we would like to eliminate diacritic reference by specific phonological rules (or constraints) to morphosyntactic and semantic features. Otherwise, we would have two distinct ways of letting morphology influence phonology, and undesirable situation. It would be a more parsimonious view to require all phonological constraints to be stated in terms of strictly phonological information. The only way morphology can influence phonology is by selecting a particular cophonology for a particular morphological construction.

The Breton problem does not pose any challenges to Bracket Erasure. Neither is reference to lexical types crucial. The different allomorphs of the definite article clitic *ar* need to refer to some morphosyntactic or semantic features of the stem they attach to. I will not formulate a phonological analysis of mutation, since the issue is rather complicated and not germane to the topic of this work (see Gahl 1995, Grijzenhout 1995). In (319), I show one allomorph of *ar*, the one that applies to feminine singular nouns and subscribes to the mutation cophonology, φ_1 .

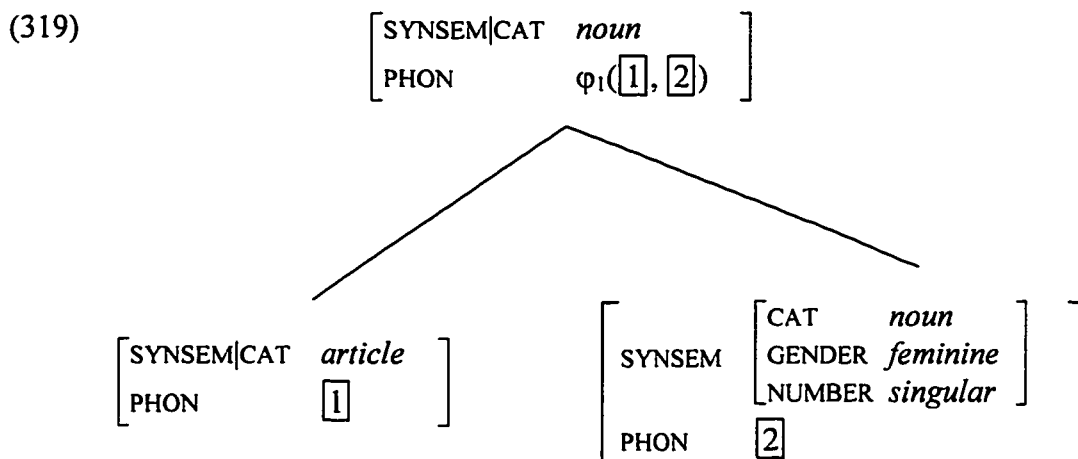

The general, nonmutating allomorph is shown in (320):

(320) Other cases: lenition does not apply

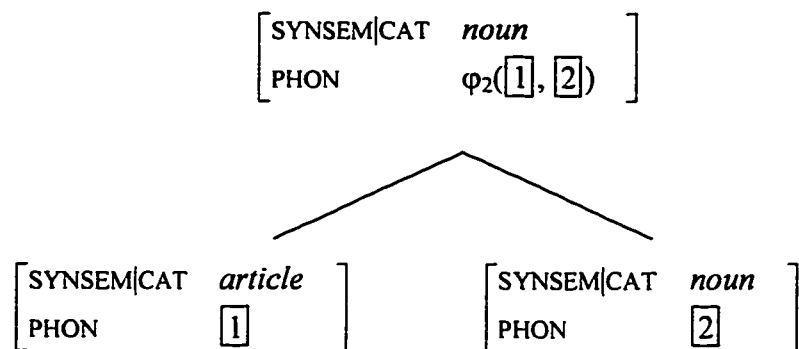

As usual, we would need to set up two subtypes of the *ar* construction, each subscribing to a different cophonology.

5.5.3 Turkish place name stress

In this section, we will see a case of cophonological allomorphy in nonconcatenative morphology. The construction of interest forms place names out of any word in Turkish, already discussed at some length in section 4.7.3, where I examined the implications of Sezer stress for level ordering. In this section, we are interested in the choice between Sezer and non-Sezer stress in place names. Stress is normally final in Turkish. However, as Sezer (1981) has shown, place name formation imposes a distinct nonfinal stress pattern. As illustrated in

(247), the final syllable is ignored, and stress falls on the antepenultimate syllable if the penult is light and the antepenult is heavy. In all other cases, stress falls on the

penultimate syllable. Following Inkelas and Orgun 1995, I call this stress pattern Sezer stress, after its discoverer.

- (321) ΗΉσ is.tán.bul, an.tál^h.ja, hak^j.k^já:ri, uis.pár.ta
 ΗΛσ án.ka.ra, mér.dzi.mek^j, ból^h.va.din, mén.te.fe
 ΛΉσ e.dír.ne, ha.íi.kár.nas, ma.láz.g^jirt, ta.ráb.ja
 ΛΛσ a.dá.na, fa.sé.íis, sy.mé.ía

As I demonstrated in section 4.7.3, Sezer stress is not a static regularity in the Turkish lexicon. Existing lexical entries (including morphologically complex ones) switch to the Sezer pattern when they are used as place names.

I now present a summary of Inkelas 's (1994) analysis of the Sezer stress pattern. The main ingredients of the analysis are the following: a single trochaic foot is assigned at the right edge of a Sezer stem. A higher-ranking constraint against a heavy syllable followed by a stressed light syllable forces this foot to be placed one syllable to the left when the penult is light and the antepenult is heavy. The constraint that requires all feet to be trochaic is never violated, and will not be shown in the tableaux. Neither will LEX≈PR, the constraint requiring every stem to have a foot. The constraints that interest us are an alignment constraint that requires the foot to be at the right edge, and the higher-ranking CONTOUR constraint (*σ_{μμ}σ_μ):

- (322) LEX \approx PR All Sezer stems must have a foot
- TROCHEE Feet are trochaic
- ALIGN(Foot, R, Word, R) All feet are at the right edge
- * $\sigma_{\mu\mu\acute{\sigma}\mu}$ A heavy syllable may not be followed by a stressed light syllable
- Ranking: * $\sigma_{\mu\mu\acute{\sigma}\mu}$ » ALIGN(Foot, R, Word, R)

The tableau in (331) shows how this ranking accounts for Sezer stress:

(323)

/kandil ^j li/	* $\sigma_{\mu\mu\acute{\sigma}\mu}$	ALIGN
kándil ^j li		*!
ϕ kandil ^j li		

/k ^j esta:ne ^j lik ^j /	* $\sigma_{\mu\mu\acute{\sigma}\mu}$	ALIGN
k ^j ésta:ne ^j lik ^j		**!
ϕ k ^j está:ne ^j lik ^j		
k ^j esta:ne ^j lik ^j	*!	

/ankara/	* $\sigma_{\mu\mu\acute{\sigma}\mu}$	ALIGN
ankára	*!	
ϕ ánkara		

/bafaran/	* $\sigma_{\mu\mu\acute{\sigma}\mu}$	ALIGN
báfaran		*!
ϕ bafáran		

I will refer to this cophonology as ϕ_s in constructions. The Sezer place name construction is depicted in (324):

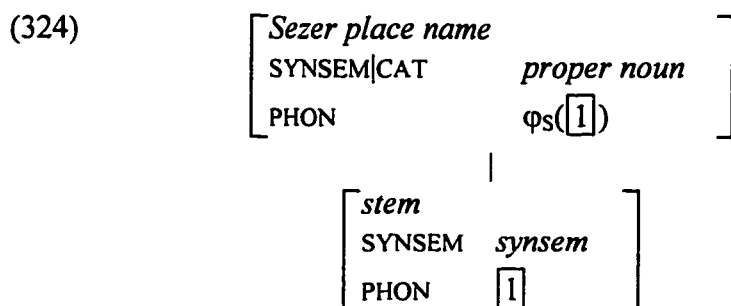

As noted by Sezer 1981b, Inkelas and Orgun 1996, there is a class of stress-neutral place names that surface with default final word stress. Some are shown in (325):

- (325)
- | | | |
|----|--------------|--------------------------------------|
| a) | katʃ-máz | ‘escape-neg.imperf’ |
| | bekʃʲe-méz | ‘wait-neg.imperf’ |
| | søjʲe-méz | ‘say-neg.imperf. (=doesn’t say)’ |
| b) | uʃʉk-lár | ‘light-pl’ |
| | sofu-lár | ‘pious-pl’ |
| | javaf-lár | ‘slow-pl (=slow ones)’ |
| | kuʃ-tʃu-lár | ‘bird-profession-pl (=bird keepers)’ |
| c) | kork-maz-lár | ‘fear-neg.imperf-pl’ |
| | dur-muʃ-lár | ‘stop-past-pl (=they have stopped)’ |

The generalization that Sezer notes is that all place names formed out of words that end in the negative imperfective (325a), noun plural (325b), or plural subject agreement (325c) suffixes are always stress neutral. Thus, we have a cophonological allomorph of the place name construction, which I will call *nonSezer place name*, and which subscribes to φ_2 , the stress-neutral cophonology. One subtype of this construction, the one that applies to plural nouns, is shown in (326):

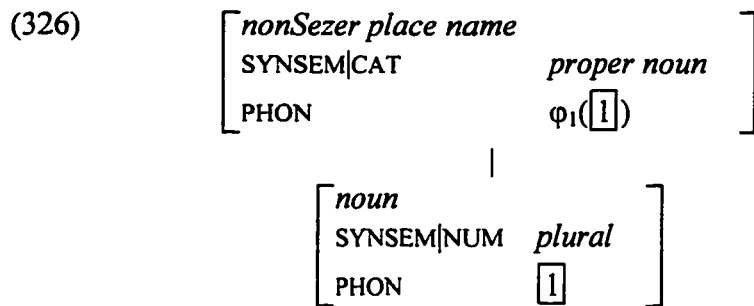

I have formulated the *nonSezer place name* construction to refer to the feature SYNSEM|NUM *plural* rather than the lexical type *plural noun* (that is, refer to the class of nouns that have the plural morpheme as the outermost morpheme in their constituent structure), because plural nouns that have further suffixes following the plural also form stress-neutral place names (I have not found any real place names that shows this; the data in (327) reflect my own judgments of made up names):

(327)	<u>word</u> kuſtʃu-lar-á ſofu-lar-dán	‘bird-agt-pl-dat’ ‘pious-pl-abl’	<u>used as place name</u> kuſtʃu-lar-á ſofu-lar-dán
-------	---	-------------------------------------	---

The part of the lexical type hierarchy that includes place names is shown in (328):

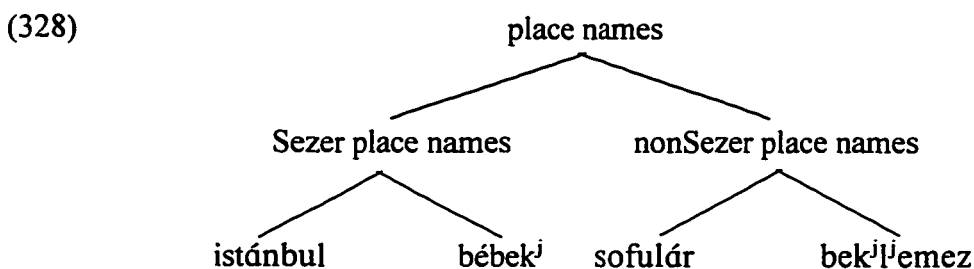

There is one neutral-stressed monomorphemic place name reported by Sezer 1981b: *anadolú*. We can handle this in our type hierarchy by listing *anadolú* as a subtype of *nonSezer place names*.

In this section, we have seen that cophonological allomorphy is applicable to nonconcatenative morphology. Place name formation, a regular morphological process in Turkish, has two cophonological allomorphs, one that assigns Sezer stress, and one that is stress-neutral. Reference to lexical types was not necessary to deal with the cophonological allomorphy of place name formation. However, the type hierarchy was useful in handling a positive exception to the stress-neutral allomorph, namely Anadolu, a place name that does not meet the morphosyntactic criteria for the stress-neutral allomorph, but nonetheless is subject to it.

5.5.4 Ulwa possessives

The example in this section involves a morpheme that is infixed into some roots and suffixed to others. The example comes from Ulwa, previously described and analyzed by Sezer 1981b, Bromberger and Halle 1989, Hale and Blanco 1989, McCarthy and Prince 1995. The possessive morpheme, underlined in (329), is infixed into most roots:

(329)	siwanak	siw <u>ak</u> anak	‘root’
	kululuk	kulu <u>k</u> aluk	‘woodpecker’
	ana:la:ka	ana:k <u>a</u> la:ka	‘chin’
	arakbus	ar <u>a</u> kkabus	‘gun’
	karasmak	kar <u>a</u> skamak	‘knee’

I present a rough analysis of Ulwa infixation in McCarthy and Prince's (1993) Generalized Alignment framework (see McCarthy and Prince 1993 for a detailed discussion). Following McCarthy, I assume two alignment constraints, one that requires *ka* to be a prefix (that is, aligned at the left edge), and another, higher-ranking one that requires *ka* to follow a foot.⁵⁸

- (330) ALIGN(*ka*, L, Word, L) *ka* must be at the left edge
 ALIGN(*ka*, L, Foot, R) *ka* must follow a foot

Ranking: ALIGN-FT » ALIGN-L

The tableau in (331) shows how these constraints derive infixation (ALIGN-L violations are measured in terms of syllables, though as McCarthy and Prince (1993) point out, it does not matter what measure is used; all we need is to be able to compare violations by pairs of candidates. Notice also that I have assumed iambic feet, but nothing depends on this assumption either, as long as every word starts with a disyllabic foot). I will refer to the ranking in (331) as φ_1 .

(331)

/ka-ana:la:ka/	ALIGN-FT	ALIGN-L
<u>ka</u> ana:la:ka	*!	
ana: <u>ka</u> la:ka		**
ana:la: <u>ka</u> ka		***!

⁵⁸ It is also possible to assume a constraint requiring *ka* to be suffix, and another that requires it to immediately follow a foot. Then, assuming only one foot at the left edge of each word is formed, the same infixation pattern follows. The choice of analysis will depend on which foot assignment is motivated in Ulwa based on independent factors. I do not know of evidence pointing either way.

Although the possessive morpheme is normally an infix, there is a lexically arbitrary class of nouns that take the possessive morpheme as a simple suffix (332):

(332)	gobament	gobament-ka	‘government’
	abana	abana-ka	‘dance’
	bassirih	bassirih-ka	‘falcon’
	ispiriŋ	ispiriŋ-ka	‘elbow’

I will call the cophonology for this suffixing allomorph φ_2 . If it is considered important that φ_1 and φ_2 should be minimally distinct, φ_2 may be formulated simply by adding a higher-ranking morpheme integrity (Spencer 1994) constraint that prevents infixation. Suffixation is then forced by ALIGN-FT.⁵⁹ Since the classes of lexical items that take the infixing versus suffixing allomorphs of the possessive morpheme are arbitrary, we must posit two inflectional classes in our lexical type hierarchy. I will simply label these *class 1* and *class 2*. Each noun root belongs to one of these two classes. The two subtypes of the possessive construction specify these two classes as the type of their morphological daughter. These two constructions are shown in (333):

(333)	Infixing allomorph	Suffixing allomorph
	$\left[\begin{array}{l} \textit{class 1 possessed noun} \\ \text{SYNSEM CAT} \quad \textit{noun} \\ \text{PHON} \quad \varphi_1(\boxed{1}, ka) \end{array} \right]$	$\left[\begin{array}{l} \textit{class 2 possessed noun} \\ \text{SYNSEM CAT} \quad \textit{noun} \\ \text{PHON} \quad \varphi_2(\boxed{1}, ka) \end{array} \right]$
	$\left[\begin{array}{l} \textit{class 1 noun} \\ \text{SYNSEM CAT} \quad \textit{noun} \\ \text{PHON} \quad \boxed{1} \end{array} \right]$	$\left[\begin{array}{l} \textit{class 2 noun} \\ \text{SYNSEM CAT} \quad \textit{noun} \\ \text{PHON} \quad \boxed{1} \end{array} \right]$

⁵⁹ Assuming exhaustive footing.

In this section, I have shown how reference to lexical types solves some long-standing Bracket Erasure problems. Sign-Based Morphology's account of these phenomena is superior to past proposals to abandon Bracket Erasure (Poser 1984, Hammond 1991), because it makes just the right amount of information about internal morphological information available to the grammar. Abandoning Bracket Erasure would make too much information available. In particular, Sign-Based Morphology allows access to the identity of the outermost morphological construction (in terms of constituent structure) in a form, but not the location of the morphological boundaries associated with that construction. I have also motivated cophonological allomorphy, that is, allomorphy in which the allomorphs have identical underlying forms, and differ solely in terms of the morphophonemic alternations they trigger. We have seen cases of reference to lexical type without cophonological allomorphy (English, section 5.3), cophonological allomorphy without reference to lexical types (Breton, section 5.5.2 and Turkish, section 5.5.3), and a case of cophonological allomorphy sensitive to lexical types (Japanese, section 5.5.1).

5.6 Cyclic effects in Cibemba

In this section, I consider apparent cyclic phonology and "interfixation" in Cibemba (Hyman 1994) from the perspective of Sign-Based Morphology's strict predictions regarding Bracket Erasure effects. The analysis will utilize analytical tools motivated in the preceding sections, namely, cophonological allomorphy and reference to lexical types.

5.6.1 Data

The basic phonological alternation we are concerned with is mutation of consonants by the causative suffix, which Hyman symbolizes as /i/.⁶⁰ Before this suffix, labials change to [f] and nonlabials change to [s] (334). Nasals do not undergo mutation.

(334)	Verb root		Causative	
	-le:p-	‘be long’	-le:f- <i>i</i> -	‘lengthen’
	-up-	‘marry’	-uf- <i>i</i> -	‘marry off’
	-lub-	‘be lost’	-luf- <i>i</i> -	‘lose’
	-lob-	‘be extinct’	-lof- <i>i</i> -	‘exterminate’
	-fiit-	‘be dark’	-fiis- <i>i</i>	‘darken’
	-ónd-	‘be slim’	-óns- <i>i</i> -	‘make slim’
	-bu:k-	‘get up’	-bu:s- <i>i</i> -	‘get (someone) up’
	-lúng-	‘hunt’	-lúns- <i>i</i> -	‘make hunt’

As Hyman shows, when the causative and applicative suffixes are both present in a stem, mutation overapplies. Both the root final consonant and the [l] of the applicative *-il* undergo mutation, although only the latter is followed by [i] in the surface form (335):

(335)	Applicative		Applicative-causative
	-le:p-el-	‘be long for~at’	-le:f-es- <i>i</i> -
	-up-il-	‘marry for~at’	-uf-is- <i>i</i> -
	-lub-il-	‘be lost for~at’	-luf-is- <i>i</i> -
	-lob-el-	‘be extinct for~at’	-lof-es- <i>i</i> -
	-fiit-il-	‘be dark for~at’	-fiis-is- <i>i</i> -
	-ónd-el-	‘be slim for~at’	-óns-es- <i>i</i> -
	-lil-il-	‘cry for~at’	-lis-is- <i>i</i> -
	-bu:k-il-	‘get up for~at’	-bu:s-is- <i>i</i> -
	-lúng-il-	‘hunt for~at’	-lúns-is- <i>i</i> -

⁶⁰ The causative suffix contains the reflex of the proto-Bantu superclosed vowel [i], which has been phonetically neutralized with regular [i] in Cibemba.

It might be thought that mutation applies iteratively from right to left (that is, involves unbounded spreading of a feature [+s]) in (335). Hyman presents the following set of data show that this analysis is not viable. The data in (336) show that mutation only applies to root final consonants, but never spreads into a root:

(336)	a)	-kálip-	‘be painful’	-kálif- *-sásif- -j-	‘cause pain’
	b)	-polopo:k-	‘crackle’	-polopo:s- *-sosofo:s- -j-	‘make crackle’
	c)	-pemeke:s-	‘pant’	-pemeke:s- *-pemese:s- -j-	‘make pant’

Likewise, the data in (337) show that mutation does not spread across the intransitive reversive suffix *-uk*, although this suffix itself undergoes mutation:

(337)	<u>Verb</u>	<u>Intransitive reversive</u>	<u>Intransitive reversive - causative</u>
	-kak-	-kak-uk-	-kak-us- *-kas-us- -j- ‘tie’
	-ang-	-ang-uk-	-ang-us- *-ans-us- -j- ‘feel light’
	-sup-	-sup-uk-	-sup-us- *-suf-us- -j- ‘be lively’

We have to conclude that mutation is local, affecting only the consonant that immediately precedes the superclosed vowel [i]. How then do we account for the double mutation in (335)?

5.6.2 Hyman's cyclic analysis

Hyman (1994) proposes an analysis of double mutation in Cibemba that uses Hammond's (1991) mechanism of morphemic circumscription. In his analysis, the causative suffix is attached first to the root, and causes mutation of the root final consonant. When the applicative suffix is attached, the causative morph is detached by morphemic circumscription. The applicative then attaches to the root. Finally, the causative is attached back to the stem which now ends in the applicative suffix, and causes the final consonant of this suffix to mutate. This analysis is illustrated with an example in (338). Note that the order of attachment of these suffixes in Hyman's analysis agrees with their scope relation.

(338)	UR	Root	le:p
	1st cycle	Affixation	[[le:p] i]
		Mutation	le:fɨ-
	2nd cycle	Morphemic circumscription	[le:f] <ɨ>
		Affixation	[[le:f] il] <ɨ>
		Mutation	le:fesɨ-

This analysis requires identifying and detaching the vowel [ɨ] as the causative morph within the stem's phonological material. This is an obvious violation of Bracket Erasure. In the next section, I will develop an alternative analysis of the data that do not require this relaxation of Bracket Erasure, and is, I will suggest, more elegant in that it makes use of cross-linguistically motivated properties of infixation.

5.6.3 Analysis based on cophonological allomorphy

In order to carry out Hyman's analysis based on morphemic circumscription, a stem needs to be identified as containing the causative suffix. We know that in Sign-Based Morphology such identification can be performed by referring to the lexical type *causative verb stem*, shown in the type hierarchy in (339):

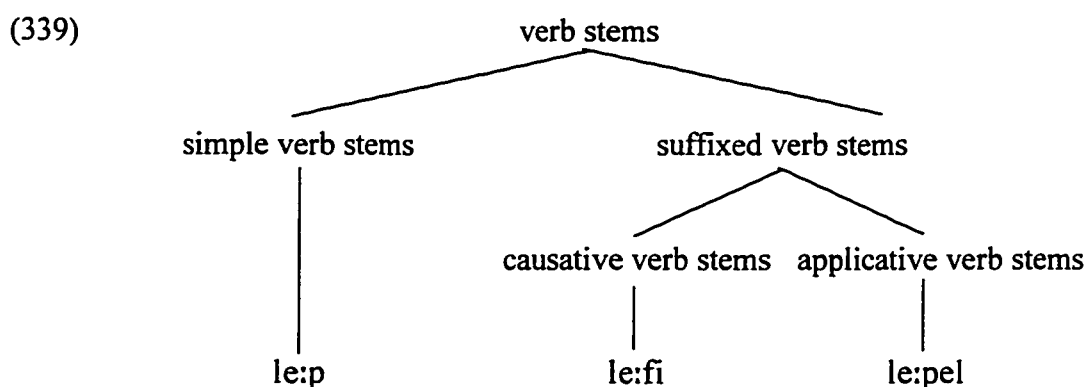

In Hyman's analysis, identification of the verb stem as a causative one is done by detaching the rightmost morph and identifying it as the causative morph. The applicative is then suffixed to the remaining part of the stem (this is an example of negative morphemic circumscription in Hammond's terminology). We have just seen that in Sign-Based Morphology, a causative verb stem can be identified without detaching any morphs, by simply referring to the lexical type of the stem. Having identified the stem as causative, is it also possible to place the applicative suffix in the right location, that is, inside the final [i] without making reference to internal morph boundaries?

I claim that the applicative suffix has two cophonological allomorph. One is an infix, and is added to causative verb stems.⁶¹ The other is a simple suffix, and is added to other verb stems. This analysis takes advantage of the fact that the location of infixes tends to be predictable crosslinguistically on the basis of phonological wellformedness considerations, as shown by McCarthy and Prince 1993, McCarthy and Prince 1994a, McCarthy and Prince 1994b, McCarthy and Prince 1995. As McCarthy and Prince show, infixes are placed so as to avoid dispreferred syllable types (onsetless syllables and closed syllables). In the Cibemba case, infixing the applicative *-il* inside the vowel [i] avoids creating an onsetless syllable, or creating a long vowel by fusing the causative [i] with the [i] of the applicative [il].⁶² Following McCarthy and Prince, I formulate an analysis of applicative infixation in the Generalized Alignment framework. An alignment constraint requires the applicative *-il* to be a suffix. A higher-ranking syllable structure constraint forces *-il* to be infixated. The constraints are shown in (340):

- (340) ALIGN(*il*, R, stem, R) Suffix *-il*
 ONSET All syllables must have onsets
 NLV No long vowel

 Ranking: ONSET, NLV » ALIGN

⁶¹ As Hyman shows, the same infixing allomorph is used with intensive stems as well, and the analysis presented here extends readily to those forms.

⁶² This would be the expected outcome if the applicative were to be added as a simple suffix, as vowel-vowel sequences undergo fusion creating a long vowel elsewhere in Cibemba.

The tableau in (341) shows how this ranking accomplishes infixation (vowel height harmony applies to the applicative suffix, but the constraint responsible for that is omitted since it is not relevant to the discussion):

(341)

/lufɨ - il/	ONSET	NLV	ALIGN
lufɨ.il	*!		
lufi:l		*!	
^σ lufisi			

I will call this infixing constraint ranking ϕ_1 . The other cophonological allomorph has a suffixing cophonology, which I will call ϕ_2 , which can be modeled simply by ranking ALIGN above all conflicting phonotactic constraints. The two cophonological allomorphs are depicted in (342):

(342) Infixing allomorph of applicative: General applicative (suffixation)

$\left[\begin{array}{l} \textit{applicative verb} \\ \text{SYNSEM CAT} \quad \textit{verb} \\ \text{PHON} \quad \phi_1(\boxed{1}, i\ell) \end{array} \right]$	$\left[\begin{array}{l} \textit{applicative verb} \\ \text{SYNSEM CAT} \quad \textit{verb} \\ \text{PHON} \quad \phi_2(\boxed{1}, i\ell) \end{array} \right]$
$\left[\begin{array}{l} \textit{causative verb} \\ \text{SYNSEM CAT} \quad \textit{verb} \\ \text{PHON} \quad \boxed{1} \end{array} \right]$	$\left[\begin{array}{l} \textit{verb} \\ \text{SYNSEM CAT} \quad \textit{verb} \\ \text{PHON} \quad \boxed{1} \end{array} \right]$

The part of the lexical type hierarchy that pertains to applicative verbs is shown in (343):

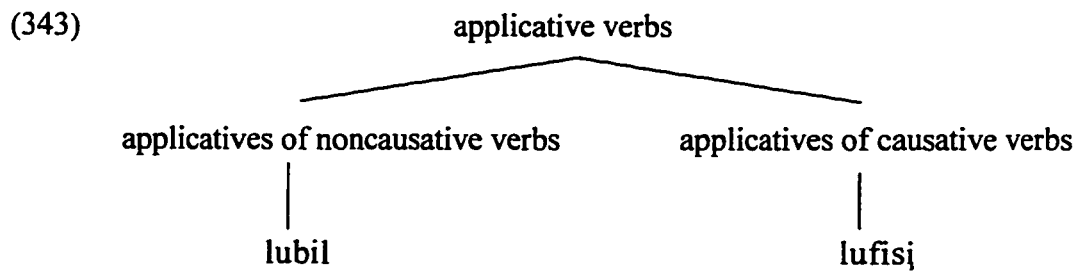

In (344), I show an example constituent structure illustrating the infixation of the applicative *-il* into a causative stem:

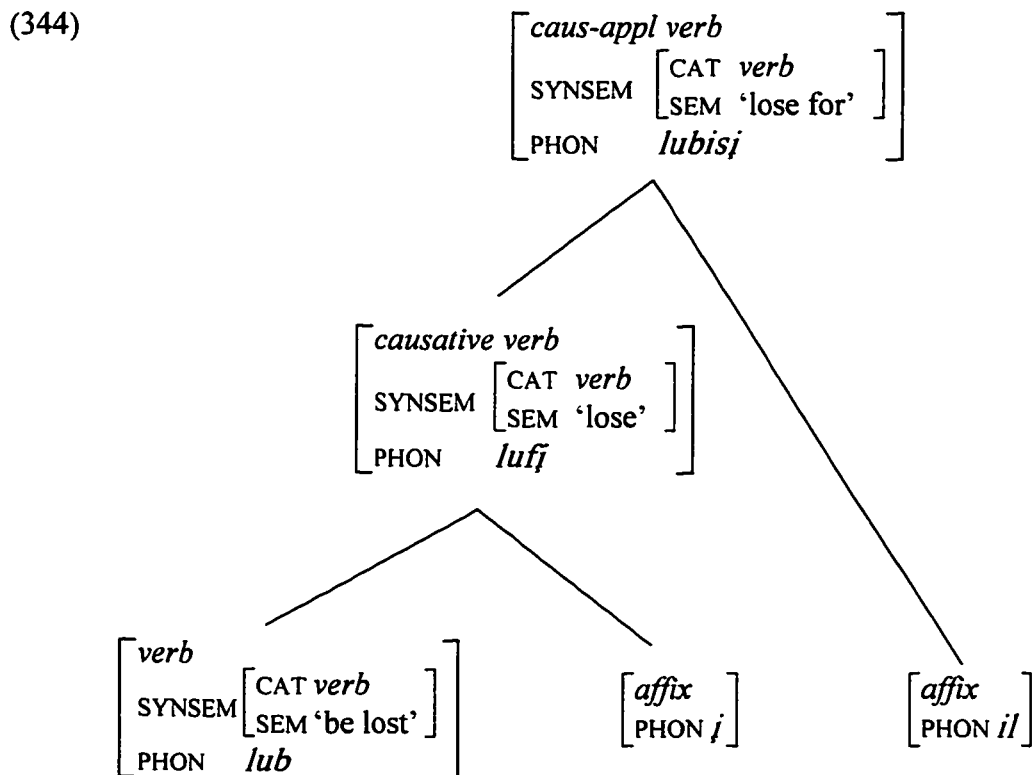

For comparison, I show a form containing the simple suffixing allomorph of the applicative in (345). In this example, the linear order of the morphs reflects their scope

relations and their hierarchical positions in the constituent structure. As expected, mutation only applies once, to the [k] of the intransitive reversive:

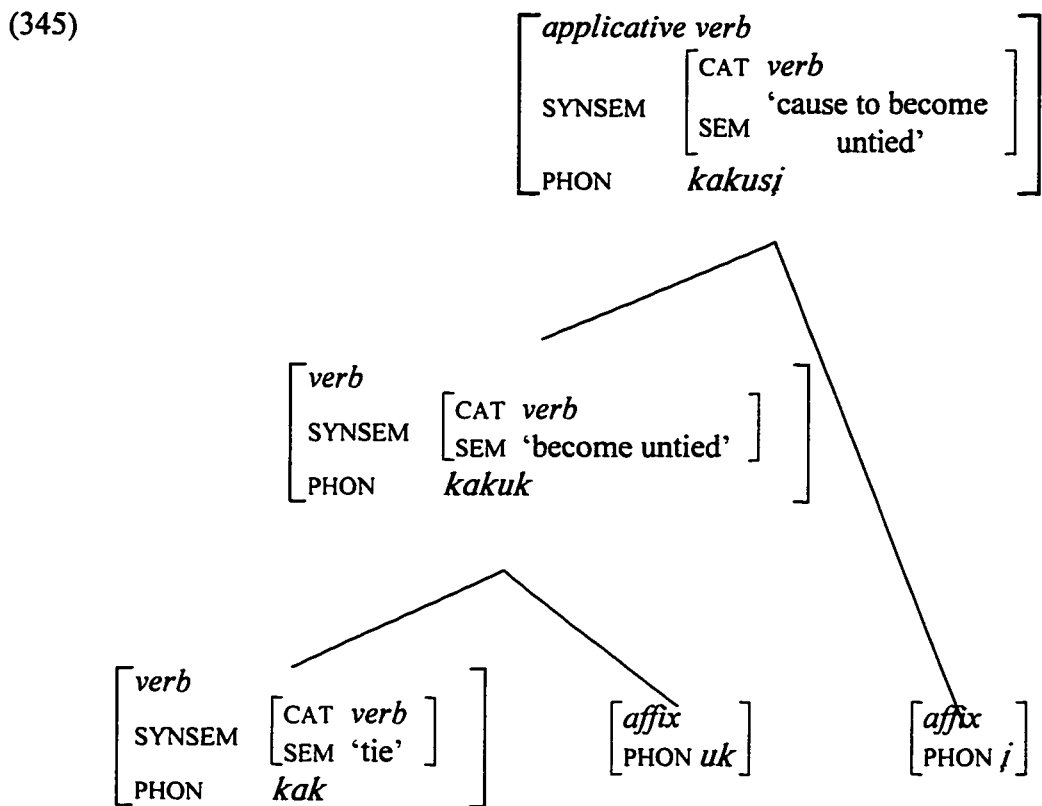

In this section, we have seen that Cibemba double mutation, a phenomenon previously analyzed by Hyman by using morphemic circumscription, can be handled in Sign-Based Morphology without violating Bracket Erasure. The reanalysis uses only independently motivated tools, namely reference to lexical types and cophological allomorphy. I furthermore claim that this analysis is superior to one using morphemic circumscription in that it relates the placement of the “interfixing” allomorph of the causative to crosslinguistic properties of infixes, namely, to the fact that infixes are placed so as to optimize syllable structure (McCarthy and Prince 1993, McCarthy and Prince 1994a,

McCarthy and Prince 1994b, McCarthy and Prince 1995 use this same reasoning to argue that their new, alignment based approach to infixation is superior to the old prosodic circumscription approach of McCarthy and Prince 1986, McCarthy and Prince 1990).

5.7 Conclusions

I have argued in this chapter that a stricter approach to Bracket Erasure effects is possible in Sign-Based Morphology than previously thought. In particular, I have shown that reference to lexical types handles phenomena previously thought to be counterexamples to Bracket Erasure. I have argued that this approach is superior to approaches such as Hammond 's (1991) morphemic circumscription. Approaches such as Hammond's make all internal morphological boundary information available to the phonology. However, I have shown that apparent counterexamples to Bracket Erasure all require reference to the fact that a certain morpheme is present in a stem, but never to the location of the morpheme within that stem. This new generalization escaped detection in old theories in which the only way the grammar could access morphological structure was through labeled brackets, which also marked morph boundaries within phonological strings. Sign-Based Morphology, by contrast, marks no morphological breakdown information within phonological strings, this task being taken over completely by the constituent structure skeleton. This architecture allowed an important generalization, previously overlooked, to emerge: the identity but not the location of the outermost morpheme (in terms of constituent structure) in a stem is accessible to the grammar.

Chapter 6. Remarks on the choice of phonological theory

In this chapter, I defend my choice of Optimality Theory as the theory of phonology to use in Sign-Based Morphology. I do this by presenting theoretical and empirical arguments against one-level phonology (Bird 1990, Scobbie 1991, Bird and Ellison 1994, Bird and Klein 1994), which is the only theory explicitly designed for use in unification-based grammar formalisms, which may therefore appear to be the obvious phonological theory of choice for Sign-Based Morphology as well.

Throughout this study, I have used Optimality Theory (Prince and Smolensky 1993) in my phonological analyses. This choice may seem unusual in the context of unification-based grammar, since, particularly in HPSG circles, it has often been taken for granted that the only way of doing phonology that is consistent with the spirit, if not the letter, of unification-based grammar is the one level approach proposed by Bird 1990, Scobbie 1991, Bird and Ellison 1994 and Bird and Klein 1994. I argue, on the contrary, that one-level phonology is not the inevitable choice of such frameworks, nor is it the optimal choice. Based on theoretical and empirical observations, I defend make the following claims:

- i) Contra Bird et al., a two-level approach to the phonological function ϕ is well within the spirit of HPSG, in fact, more so than a one-level approach.
- ii) The computational advantages of the one-level approach may be taken by some linguists as sufficient reason to adopt it, but

- iii) The one level approach faces serious empirical difficulties because of its failure to distinguish between structure filling and structure changing phonological alternations.
- iv) Bird and Ellison's (1994) arguments against rule-based approaches based on considerations of conspiracies (Kisseberth 1970) need not apply to all two-level approaches. There are surface oriented two-level theories (such as the two-level version of Optimality Theory proposed by McCarthy and Prince 199a,b, and used in the present study) that do not miss generalizations the way rule-based theories are claimed to.

I conclude that a two-level approach to the phonological function ϕ is a natural choice from a theoretical point of view, and is also empirically superior.

6.1 One level phonology

The leading idea in one-level phonology is that there is only one phonological description for any given linguistic form. The "surface" phonological string is one that simultaneously satisfies all constraints. Bird and Ellison (1994) make an analogy with syntax: in traditional transformational grammars, syntactic representations are manipulated by rules and changed into new representations. In most modern theories of syntax, most explicitly in unification-based theories such as HPSG, there is only one syntactic representation that satisfies all constraints imposed on it. Thus, Bird and Ellison 1994 argue, phonology in a declarative, unification-based theory of grammar must be one level as well.

In this section, I give a brief informal illustration of one-level phonology taken from Bird and Klein 1994, who assume the following feature geometry, adapted from Clements 1985. (The type *boolean* identifies a binary valued feature with possible values + and -. It is not clear how privative features are best modeled in this framework):

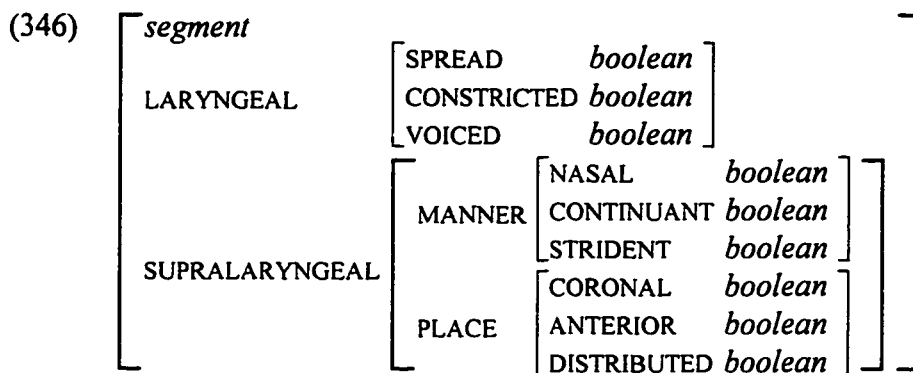

Bird and Klein 1994 make a fundamental contrast between objects and descriptions. Phonological representations are taken to be partial descriptions of phonetic events. Grammatical constraints are also partial descriptions of phonetic events. Each grammatical construction and lexical entry present in an utterance contributes to a pool of constraints on the object being described. A fully specified phonological representation results from the combination of constraints imposed by lexical entries and grammatical constructions. This fully specified representation is a maximally specific description of a phonetic event.

The phonological domain consists of descriptions. A partial description is satisfied by a class of objects. The more specific a description is, the smaller is the class of objects that satisfy it. Since phonological representations are descriptions, it is possible

to use tools such as disjunction, negation, and implicational statements in grammatical constraints as well as lexical representations. Bird and Klein 1994 make full use of these tools. For example, suppose we want to add a statement of nasal place assimilation to our grammar. The following constraint (347) disallows nasals followed by stops of a different place of articulation (the symbol \neg stands for negation):

$$(347) \quad \neg_{\text{phrase}} \dots \left[\begin{array}{c} \text{segment} \\ \text{MANNER|NASAL +} \\ \text{SL} \left[\begin{array}{c} \text{PLACE} \\ \boxed{1} \end{array} \right] \end{array} \right] \left[\begin{array}{c} \text{segment} \\ \text{MANNER|CONT -} \\ \text{SL} \left[\begin{array}{c} \text{PLACE} \\ \neg \boxed{1} \end{array} \right] \end{array} \right] \dots$$

This constraint rules out a nasal segment followed by a stop whose place of articulation is not shared with the nasal. The additional assumption that lexical representations contain nasals unspecified for place completes the account of nasal place assimilation.

6.2 Cyclic effects in one-level phonology

Perhaps surprisingly, one-level phonology can deal quite elegantly with cyclic phonological effects (Cole and Coleman 1993). The main restriction imposed on phonology by Bird and Klein is that no deletion or structure changing (delinking) is allowed. The issue of cyclic versus noncyclic phonological effects is largely independent of whether the alternations involved are structure filling or structure changing. Even though I have formulated a number of alternations as structure changing in this study, most of those analyses can be restated in one level terms by using disjunctions in lexical representations to avoid structure changing alternations. It is therefore no necessarily the case that an approach to phonology that adopts Bird and Klein's principle of

compositionality must necessarily be one-level or terminal-based (that is, committed to the absence of cyclic effects).

To see how cyclic effects can be handled in one-level phonology, consider the following representation of the English third person plural agreement suffix adopted from Bird and Klein 1994:

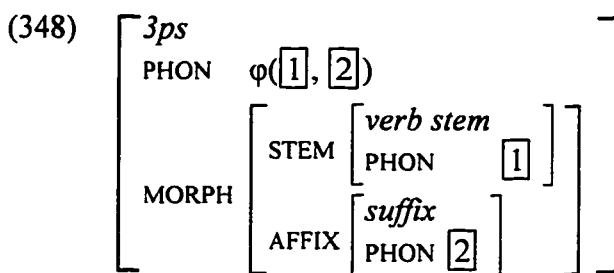

This representation is equivalent to the Sign-Based Morphology representations in the earlier chapters of this work where affixes were represented as constituents. Just like in Sign-Based Morphology, Bird and Klein 1994 represent affixes as constructions, or, as they call them (following Riehemann 1994), as partially specified stems.

Bird and Klein 1994 impose the following constraint on the phonological function

φ :

- (349) Phonological compositionality: The phonology of a complex form can only be produced by either unifying or concatenating the phonologies of its parts.⁶³

⁶³ The difference between unification and concatenation is subtle, and not important to our purposes here. Essentially, unification refers to combining partial descriptions of a single string into a more specific description. Concatenation involves the usual operation of adding two strings together to form a longer string.

This principle of phonological compositionality in effect rules out all structure changing phonology: it requires every piece of phonological information present in a daughter node to also be present in the mother node. According to the principle of compositionality, there cannot be any phonological deletion, deletion, or change in feature values.

Since cyclic phonological effects do not necessarily occur with structure changing alternations, but may be found in structure filling alternations as well, it is not surprising that Bird and Klein 1994's approach to phonology can handle them. For example, my treatment of the Turkish disyllabic minimal size condition in section 2.1 uses only structure-filling phonology (that is, no deletion of phonological material is used), and is therefore fully compatible with one-level phonology. To illustrate this point, I repeat the constituent structure for the ungrammatical form **do:-m-u* 'my C-acc' here. This form is ungrammatical because the subconstituent **do:-m* 'my C' violates the disyllabic minimal size condition, even though the whole word contains the requisite two syllables:

(350)

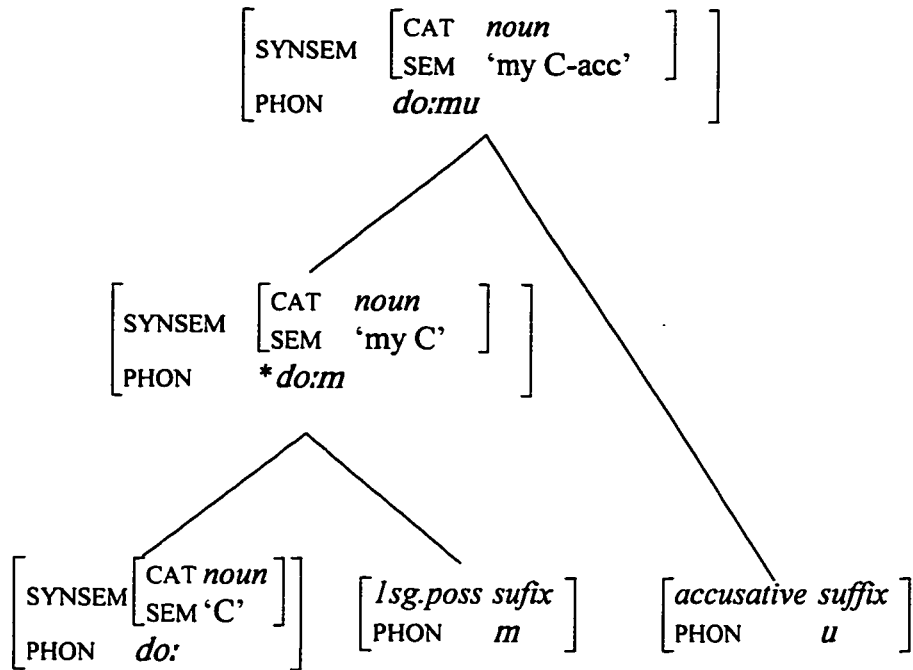

Notice that in this example the mother node phonology is always the concatenation of the daughter node phonologies. The analysis is therefore compatible with Bird and Klein Principle of Compositionality.

The status of structure changing phonological alternations is more interesting. This problem is independent of cyclic effects. Therefore, I discuss it in a separate section.

6.3 Structure changing alternations

Consider first a structure filling phonological alternation, defined as one that can be modeled by underspecification. Turkish vowel harmony is such a case (Clements and Sezer 1982). For simplicity, I will only discuss front/back harmony, though the language also has rounding harmony. I will ignore disharmonic forms (e.g., *anne* 'mother', *inan* 'believe') for now, since it is necessary to use defaults, a mechanism we have not

discussed yet, to handle such forms. The issue of defaults will come up again in section 6.4.2.⁶⁴

Disharmonic forms aside, the generalization is that only the first vowel in a word is distinctively specified for frontness. All others agree with the first one (351):

- (351) *ev-l̥er-in-de* ‘house-pl-poss-loc’
at-lar-urn-da ‘horse-pl-poss-loc’

This alternation can be handled in one-level phonology by making a few assumptions. First, we assume that the initial vowel of each root is specified as front or back. Second, we assume all noninitial root vowels as well as all suffix vowels are unspecified for frontness. Finally, we make the following constraint part of the grammar (352):

- (352) $\neg_{word} \dots \left[\begin{array}{c} \text{vowel} \\ \text{FRONT } \boxed{1} \end{array} \right] \text{consonant}^* \left[\begin{array}{c} \text{vowel} \\ \text{FRONT } \neg \boxed{1} \end{array} \right] \dots$

This constraint rules out consecutive vowels (with possible intervening consonants) that do not agree in frontness.

This analysis, which follows Clements and Sezer in spirit, is structure-filling, as we have assumed that noninitial vowels are lexically underspecified. Thus, the lexical representation for the word *evl̥erinde* is as shown in (353), where all suffix vowels are unspecified for frontness (following the tradition in Turkic linguistics, capital letters are

⁶⁴ Defaults are used in some versions of Construction Grammar (Lakoff 1987, Goldberg 1992).

used to indicate vowels that are specified for every relevant feature except, crucially, for frontness).⁶⁵

(353) ev-^{l̥}Er-In-dE

This lexical representation can successfully unify with the harmony constraint in (352), which requires all consecutive vowels to agree in frontness. The resulting fully specified representation has all front vowels (354):

(354) ev^{l̥}erinde

Let us turn to structure-*changing* phonological alternations. These pose a more interesting challenge to the Principle of Compositionality, since the apparent lexical representations do not unify with the observed surface ones. Lexical underspecification is not generally an option, as it would incorrectly neutralize needed contrasts. By way of illustration, consider the neutralization of all syllable codas to [h] in Slave (Rice 1989):

⁶⁵ The [l̥] in the second morpheme in this form is assumed to be unspecified for palatality.

(355)	<u>noun</u>	<u>my noun</u>	<u>gloss</u>
	seh	se-zég-é	'saliva'
	xé:h	se-yé:l-é	'pack'
	xah	se-ɣal-é	'club'
	sah	se-zah-é	'bear'
	teh	se-léh-é	'coal'
	ʃih	se-zih-é	'rock'
	ʔuh	se-lur-é	'scab'
	ʃih	se-ʒíð-é	'mountain'
	xoh	se-ɣoz-é	'thorn'
	xenih	se-ɣenih-é	'raft'
	ʔuh	se-luz-é	'spoon'

The following consonants are seen to neutralize to [h] in (355): [g, l, r, ð, z].⁶⁶

Underspecification of lexical entries clearly is not enough to handle this alternation in a structure filling manner (that is, without any deletion) as required by Bird and Klein's Principle of Compositionality. How can one-level phonology then deal with this phenomenon?

Recall that the phonological domain consists of descriptions rather than objects, and that logical operations such as disjunction are available. The solution is, thus, to use disjunctions to handle apparently structure changing alternations (Bird and Ellison 1994, Bird and Klein 1994). In the Slave case, we need to assume that all root final consonants are specified by a disjunction between [h] and another consonant in the Slave inventory (356):⁶⁷

⁶⁶ I have not found examples with other consonants.

⁶⁷ In (356), the curly brace notation is used to express disjunction, as in SPE.

$$(356) \left[\begin{array}{l} \text{SYNSEM} \left[\begin{array}{l} \text{CAT} \textit{ noun} \\ \text{SEM} \textit{ 'spoon'} \end{array} \right] \\ \text{PHON} \{l, \text{ʃ}\} u\{h, z\} \end{array} \right]$$

Next, we introduce a constraint that requires all codas to be [h]. Further, in order to prevent neutralization from applying to these consonants when they are in onset position, we need a constraint that prohibits [h] from occurring in that position. The problem with this move is that there are morphemes that have a nonalternating [h] that surfaces as such even in onset position. How can we prevent such forms from being judged ungrammatical?

The only solution to this problem is to invoke defaults, thus making the onset constraint applicable only to the disjunctively specified segments. Using the slash notation for defaults, we can state the onset constraint as follows:

$$(357) \text{ONSET} \Rightarrow / \neg h$$

Given a lexical specification like {h,z}, this constraint will force the alternant that is not [h] to occur.

(358) Lexical representation:	{l,ʃ}u{h,z}-é
Constraint:	ONSET \Rightarrow / \neg h
Result:	luzé 'spoon-poss' (constraint satisfied)

When the lexical specification is [h], the constraint will have to be overridden.

- (359) Lexical representation: {ʃ,ʒ}ih-é
 Constraint: ONSET ⇒ /-h
 Result: ʒihé ‘song-poss’ (constraint overridden)

We have seen that it is necessary to use defaults to deal with some structure changing alternations. This is slightly misleading in that defaults prove to be necessary to deal with certain alternations that are structure filling as well.⁶⁸ Disharmonic forms in Turkish can be handled in a similar fashion by formulating the harmony constraint as a default one.

- (360) Turkish vowel harmony (revised):

$$word \dots \left[\begin{array}{l} vowel \\ FRONT \boxed{1} \end{array} \right] consonant^* \left[\begin{array}{l} vowel \\ FRONT \neg \boxed{1} \end{array} \right] \dots$$

Harmonic morphemes can, and therefore must, satisfy this constraint:

- (361) Lexical representation: at-{\l,lʲ}{a,e}r
 Result: atlar ‘horses’ (constraint satisfied)

Disharmonic morphemes have fully specified vowels (rather than disjunctions between front and back vowels). Therefore they cannot satisfy the constraint, which is therefore overridden:

⁶⁸ That is, alternations that can successfully be handled by underspecifying a feature value without recourse to other types of disjunction.

(362) Lexical representation: at-k^jen
 Result: atk^jen ‘horse-adv’ (constraint overridden)

The tools necessary to deal with structure changing alternations are disjunctions and defaults. While this can still be considered one-level phonology, it must be noted that it is not monotonic,⁶⁹ since it utilizes defaults and overrides (this is a more serious matter than using defaults in the type hierarchy, since defaults in the phonological mapping will give rise to nonmonotonicity in the on-line computation of actual forms, and will effectively cancel the computational advantages that form the strongest original motivation for one-level phonology).⁷⁰

6.4 Critique of one-level phonology

6.4.1 The spirit of unification-based theories

Bird and Ellison 1994, Bird and Klein 1994 claim that their principle of phonological compositionality is required by the spirit of a constraint-based approach. They do acknowledge that the HPSG formalism (nor any other unification-based phrase structure formalism) does not impose any constraints on the kinds of phonological relations

⁶⁹ Part of the definition of monotonicity is that all constraints are surface-true. That is, no loss of information is allowed. While the extension of one-level phonology I have described in this section manages to avoid outright deletion, there is nonetheless inherent loss of information in overriding a constraint. The system is therefore nonmonotonic, and thus loses much of its formal and computational appeal.

⁷⁰ Furthermore, note that using defaults and overrides amounts to admitting that it is after all acceptable to use Optimality Theory as the theory of phonology, since Optimality Theory is a theory of constraint conflict resolution, which may simply be viewed as defaults (lower ranking constraints) being overridden by higher-ranking constraints.

between a daughter node and a mother node, and therefore structure changing phonology is allowed by the letter of unification-based formalisms. Indeed, Krieger et al. 1993 take an approach to phonology that does not assume the principle of compositionality, and is very similar to the one I adopt in this work. Krieger et al. 1993 analyze the alternations in the German second person singular suffix (363) using Finite State Transducers (Hopcroft and Ullman 1979, Koskeniemi 1983).

(363)	sag-st	‘say’
	αɤbart-əst	‘work’
	mɪks-t	‘mix’

The relation between the daughter and mother node phonologies can be directly incorporated into the construction, as shown for *αɤbart-əst* (364) and *mɪks-t* (365) (the symbol $_$ indicates concatenation):⁷¹

(364)	$\left[\begin{array}{l} \text{PHON} \quad \boxed{1} _ \boxed{2} \\ \text{MORPH} \quad \left[\begin{array}{l} \text{STEM} \quad \boxed{1} \quad \dots \{t, d\} \\ \text{SUFFIX} \quad \boxed{2} \quad st \end{array} \right] \end{array} \right]$
-------	---

(365)	$\left[\begin{array}{l} \text{PHON} \quad \boxed{1} _ \boxed{2} \\ \text{MORPH} \quad \left[\begin{array}{l} \text{STEM} \quad \boxed{1} \quad \dots \{s, z, x\} \\ \text{SUFFIX} \quad s _ \boxed{2} \quad t \end{array} \right] \end{array} \right]$
-------	--

⁷¹ Attribute value representations of Finite State Transducers (à la Krieger et al.) tend to be very clumsy. It is therefore usual to use a direct representation of the alternation in visual presentations, as I do here.

Examples (17) and (18) show that both the insertion of [ə] and the deletion of [s] can be handled quite straightforwardly within the HPSG formalism. However, Bird and Klein 1994 state that structures like those in (364) and (365) should be eschewed because they violate the Principle of Phonological Compositionality, which ensures that information combining operations at the phonological level (that is, mechanisms that related daughter node phonologies to mother node phonologies) are monotonic,⁷² in the sense that all information in the daughters is present also in the mother. They hold that this restriction is required by the spirit of a constraint based formalism. The constructions in (364) and (365) utilize insertion (of [ə]) and deletion (of [s]). They are therefore incompatible with the principle of compositionality.

Although Bird and Klein argue that constructions such as those in (364) and (365) should be disallowed because they violate the principle of compositionality, my contention is that the principle of phonological compositionality is not required by the “spirit of unification-based frameworks”. On the contrary, the foundation of unification-based grammatical theories is that such a principle does not in general apply to phrase structures. To elucidate this point, consider the following figure, adopted from Bird 1990, that is intended to illustrate the basic architecture of a unification-based model of linguistics:

⁷² For our purposes, we may assume this to mean that:

- i) there is no deletion of phonological material supplied by lexical forms, and
- ii) all grammatical constraints are obeyed.

(366)

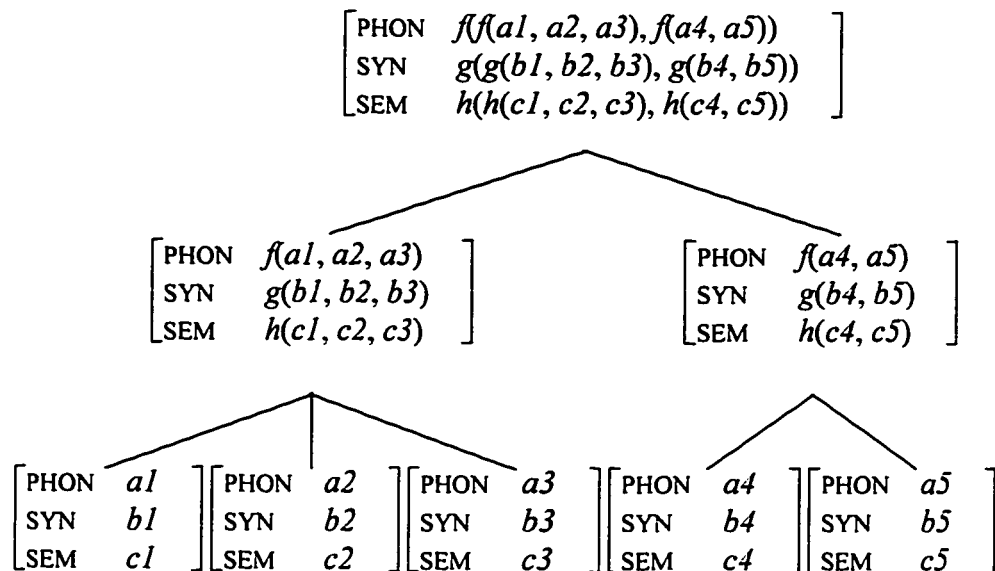

Notice that the syntactic and semantic functions g and h are not subject to anything like Bird and Klein 1994's principle of compositionality. There is no general condition in HPSG or any unification-based theory that all features of a daughter node must also be found in its mother or that a mother node's features must consist of the unification of its daughters' features. In fact, a moment's reflection is sufficient to show that the sign-based architecture would have been unnecessary if such a restriction held. If nonterminal nodes contained all and only the information present in the terminal nodes, then it would have sufficed to enter such information solely in terminal nodes. Repeating the information in nonterminal nodes would have been redundant. The only point of enriching nonterminal nodes with their own information content is that the information content of a nonterminal node differs from the information content of its immediate constituents.

Furthermore, it is quite straightforward to show that such a principle cannot be defended in any interesting way in general for features other than phonology. Consider for

example the following morphological constructions in Turkish: one applies to nouns, and verbalizes them by adding the suffix *-le ~ -la*:

(367)	<i>imza:</i>	‘signature’
	<i>imza-la</i>	‘sign’
	<i>tuz</i>	‘salt (N)’
	<i>tuz-la</i>	‘salt (V)’

The other applies to verbs, and nominalizes them by adding the suffix *-if ~ -ulf*:

(368)	<i>imza-la-julf</i>	‘a signing’
	<i>tuz-la-julf</i>	‘a salting’
	<i>g’el’i</i>	‘come’
	<i>g’el’i-if</i>	‘a coming’

Now, if we wanted to hold that the mother’s category feature had to be identical to its daughter’s (in accordance with a categorial analog of Bird and Klein’s Principle of Compositionality), we would have to posit that in the lexicon, both roots *imza:* ‘signature’ and *g’el’i* ‘come’ are specified for a disjunction of the features *verb* and *noun* (since words containing these suffixes can be verbs or nouns). But now we have no way expressing the contrast that one is a verb and the other is a noun, since they both have exactly the same lexical feature specification. We must conclude that no Principle of Compositionality can possibly hold on the percolation of syntactic category features.⁷³ Thus even if a Principle of Compositionality did hold on phonological features, it would

be stipulated, rather than inevitable. That is, it is untenable to argue that the spirit of unification-based theories requires the principle of phonological compositionality (since analogous principles do not hold on syntactic and semantic features). The principle of phonological compositionality reduces to a stipulation specific to phonology. If such a principle could indeed be shown to hold on phonology (while it does not hold on syntactic and semantic information), this would be somewhat of an embarrassment for the unification-based approach, and a return to Lieber's hybrid model (where phonology is modeled in a terminal-based fashion, but all other information is treated in a sign-based fashion) would perhaps be warranted.⁷⁴

I conclude therefore that Bird and Klein 1994's principle of compositionality is not only not required by the spirit of unification-based theories, but is in fact very much counter to that spirit. The approach adopted in this work, which essentially states that mother node features are related to daughter node features by a set of constraints is in the spirit of a constraint based theory. The nature of these constraints is of course the subject matter of phonological theory. I have used Optimality Theory as my phonological theory in this study, but for the computationally oriented, the Finite State Transducer based approach of Krieger et al. 1993 is an attractive alternative.

⁷³ I show in section 6.4.2 that a very similar argument can be constructed specifically against the principle of *phonological* compositionality.

⁷⁴ While Bird and Klein 1994 retain enough two-level tools that their approach cannot be justly considered terminal-based, the approach taken by Cole and Coleman 1993, Walther 1995 can be regarded as equivalent to a terminal-based treatment of phonology within an otherwise explicitly sign-based framework.

6.4.2 Bengali laryngeal assimilation

In this section, I will construct an empirical argument against the principle of phonological compositionality based on laryngeal assimilation in Bengali (Kenstowicz 1994), where coda consonants assimilate to the laryngeal features of following onset consonants (369):

- (369) a) *ʃat* *b^hali* *ʃadb^hali*
 ‘seven’ ‘brothers’
- b) *mɔd* *k^haoa* *mɔtk^haoa*
 ‘alcohol’ ‘drinking’

To handle the alternation in (369a), we may posit that lexically, this root is specified for a disjunction between a final [t] and a [d]. Note that underspecification will not be sufficient here, since too many laryngeal contrasts are neutralized (370):

- (370) *ʃat* *b^hali* *ʃadb^hali*
 ‘seven’ ‘brothers’
- pɔt^h* *dæk^ha* *pɔddæk^ha*
 ‘road’ ‘seeing’

The representation of the root *ʃat* ‘seven’ will then be as shown in (371):

- (371) PHON *ʃa{t, d}*

Next, consider the root in (369b). For similar reasons, this root will also have to be specified for a disjunction between a final [t] and [d]. The phonological specification of this root is given in (372):

(372) PHON $m\alpha\{t, d\}$

Notice that in our attempt to model an apparently structure changing alternation in one-level terms, we have lost the contrast between the two lexical forms. There is no way to recover the non-preconsonantal contrast the two roots exhibit (*fat* versus *mαd*). Whatever constraint we devise to force *fat* to appear with a [t] will also cause *mαd* to appear with one, resulting in **mαt*. Conversely, if we posit a constraint that handles *mαd*, then we will also predict **fad*. We somehow need to indicate that one of the disjuncts is the “preferred” one, that is, the one that will surface unless some constraint forces the other one to surface. But that would be equivalent to specifying the lexical representation for the “preferred” variant, and letting the responsible grammatical constraint override this specification. Since overrides have to be allowed anyway (as I have shown in section 6.3), we might as well give up the principle of compositionality.

I conclude that one-level phonology, although computationally attractive, is not empirically adequate as a theory of phonology. Nor is it required by the letter or spirit of a constraint based grammar framework. The only remaining objection to two-level approaches presented by Bird and Ellison 1994, Bird and Klein 1994 is based on their rule orientation. Since rule based theories emphasize processes rather than output

structures, they tend to lose generalizations concerning wellformed output structures. This is the well-known issue of conspiracies. This criticism, however, does not apply to all two-level theories. In particular, Optimality Theory is a two-level approach to phonology that does not lose explanatory power in this way, as I have discussed in Orgun 1996a. See also McCarthy 1996b for a particularly lucid discussion of this issue.

Chapter 7. Conclusion

I started this study with a list of desiderata for a theory of the phonology-morphology interface. Existing theories of the phonology-morphology do not satisfy these desiderata too well. This has been my main motivation for developing Sign-Based Morphology. In this chapter, I return to the desiderata and show that Sign-Based Morphology indeed satisfies each one in a principled fashion. I repeat those desiderata here:

- (373) a) Account for cyclic phonological effects
- b) Account for noncyclic phonological effects
- c) Relate the cyclic-noncyclic contrast to independently motivated morphological properties of words
- d) Predict the inside-out nature of cyclic effects
- e) Account for Bracket Erasure effects (do not allow unlimited reference to the internal structure of words by the grammar)
- f) Handle challenges to Bracket Erasure
- g) Account for “level economy” effects (the exemption of forms from the phonology of levels where they do not undergo morphology) and other departures from level ordering
- h) Use only independently motivated analytical tools

The theory developed in this thesis, Sign-Based Morphology is a declarative, unification-based approach to morphology. It satisfies each of the desiderata above.

It derives cyclic and noncyclic phonological effects from branching and flat constituent structures, respectively. In Turkish, the flat and branching structures motivated by the apparent cyclic versus noncyclic application of a disyllabic minimal size condition match the structures motivated by Suspended Affixation.

Unlike paradigmatic approaches to the phonology-morphology interface, Sign-Based Morphology predicts the inside-out nature of interleaving (cyclicality and level ordering) effects. Simple forms are never affected by complex forms, because complex forms are not constituents in the structure of simple forms.

Bracket Erasure effects are handled in Sign-Based Morphology with any brackets or any erasure. They follow from the assumption that no morphological information whatsoever is represented within phonological strings. This lack of morphological information in phonological strings is desirable regardless of Bracket Erasure effects, since there are serious problems with such segmentation of phonological strings into morphs.

Challenges to Bracket Erasure are handled by reference to lexical types. Types are used extensively in unification-based theories of grammar to capture generalizations, and to impose conditions on classes of objects. Thus, type hierarchies are independently motivated; they are not an ad-hoc tool introduced to encode some morphological structure information within signs. The Sign-Based Morphology approach to reference to lexical types makes an interesting and novel prediction: the identity, but not the location, of the outermost morphological construction (in terms of constituent structure) within a form can be accessed by the morphology. Other theories of morphology either allow no access

at all to morphological structure (too little information), or access to the identity as well as the location of a morpheme within a form (too much information, as I claim that the location is never relevant to the grammar). Only Sign-Based Morphology captures this new contrast between phonology and morphology that I have surfaced by careful examination of apparent violations of Bracket Erasure effects.

In Sign-Based Morphology, the application of phonology is dependent on morphological constructions. Phonology relates the mother node's phonological string to its daughters' strings. This construction-driven understanding of phonology paves the way to successful handling of level economy, looping, and other departures from level ordering.

Sign-Based Morphology does not use any ad-hoc mechanisms. All the tools used have ample independent motivation.

Cyclic effects follow from constituent structures and feature percolation. Percolation is used in every theory that uses constituent structures. The Sign-Based Morphology technique of including phonology in the scope of percolation cannot be regarded as an added tool. On the contrary, it gives rise to a more coherent theory than, say, Lieber's, where every type of information except phonology is subject to percolation.

The other main analytical device in Sign-Based Morphology is lexical types. Not only are those common in unification-based theories, they also serve a number of useful functions in morphological theory proper. For example, as Riehemann 1993, Inkelas and Orgun 1994, Koenig and Jurafsky 1994, Riehemann 1994, and Inkelas and Orgun 1995 show, they provide perhaps the only workable way to deal with marginally productive and

unproductive morphology in a constituent structure-based morphology. Since lexical types are useful for so many different purposes, it should be considered fortunate that the grammar turns out to make reference to them. Any information encoded within lexical items but never accessed by the grammar is suspect. The demonstration in this thesis that reference to lexical types provides a principled and tightly constrained tool to deal with apparent challenges to Bracket Erasure provides further support to unification-based theories with type hierarchies.

Sign-Based Morphology thus satisfies all of our desiderata. Furthermore, it compares favorably to alternative approaches to morphology.

Lexical Phonology also deals with cyclic and (by stipulation) noncyclic phonology. It accounts for Bracket Erasure effects by stipulation. It handles departures from level ordering in a brute-force fashion by introducing additional tools. It has no principled way to deal with apparent violations of Bracket Erasure.

Lieber's constituent structure-based view of morphology provides many of the insights that Sign-Based Morphology utilizes. Like Sign-Based Morphology, Lieber's theory makes extensive use of feature percolation. Like Sign-Based Morphology, Lieber represents affixes as partial words, that is, as constituent structures with an unspecified stem. Sign-Based Morphology differs from Lieber in including phonology in the scope of percolation. This allows Sign-Based Morphology to offer a more satisfactory account of nonconcatenative morphology, which Lieber is forced to relegate to a separate, transformational, component of the lexicon.

Like realizational approaches to morphology, Sign-Based Morphology offers a uniform treatment of concatenative and nonconcatenative morphology. However, Sign-Based Morphology is better able to handle an important difference between the two types of morphology: by introducing affixal (and, in general, “marker”) material as a fixed argument to the phonological function that relates mother and daughter nodes, Sign-Based Morphology is able to impose more restrictions on the theory of phonology. In particular, phonological deletion, just like morphological subtraction, targets tightly restricted packages of material (usually characterized as a single metrical constituent). Phonological insertion is similarly restricted. However, morphological insertion (that is, affixation) is not restricted in the same way. Affixes may introduce arbitrary amounts and types of phonological material (e.g., Turkish *-dzesine*, an adverbializing suffix that attaches to nouns, or *-mturak*, a diminutive suffix that attaches to adjectives). Traditional realizational approaches therefore have to allow insertion of arbitrary amounts of phonological material. But this leads to the loss of the important generalization that phonology never introduces such material.

Sign-Based Morphology has a plausible paradigmatic interpretation. A constituent structure can be seen as a statement of relationships between signs, each of which exists as an actual (stored) or potential (one that can be licensed by constructions) lexical form. However, the similarities between Sign-Based Morphology and other paradigmatic approaches to morphology end here. Other paradigmatic approaches have no satisfactory way of dealing with both cyclic and noncyclic phonological effects. They do not predict the inside-out nature of interleaving effects. Most paradigmatic approaches to

morphology are word based. As such, they are unable to deal with bound complex stems that function as cyclic phonological domains, such as the Bantu verb stem.

Sign-Based Morphology combines insights from item-and-arrangement, item-and-process, and word-and-paradigm style approaches to morphology. Those approaches are usually thought to be radically different from, and incompatible with, each other. Sign-Based Morphology shows that this is a misconception. Its unique combination of insights from all these approaches allows it to account for a wider range of phenomena in a more principled fashion than other theories.

Several issues remain to be studied. The most obvious one is the question of bracketing paradoxes, that is, mismatches between morphologically and phonologically motivated constituent structures. While I have addressed some phenomena that could be considered Bracketing Paradoxes in chapter 5, a comprehensive study still remains to be conducted.

Another important area of research I have not touched on is the phonology-syntax interface.

Finally, more work on the cognitive and computational aspects of Sign-Based Morphology promises to be interesting.

References

- Ackerman, Farrell and Philip LeSourd. 1993. Towards a lexical representation of complex predicates. Presented at the complex predicates workshop, Stanford University.
- Allen, Margaret. 1978. *Morphological investigations*. Doctoral dissertation, University of Connecticut.
- Anderson, Stephen R. 1992. *A-Morphous Morphology*. Cambridge: Cambridge University Press.
- Baker, Mark C. 1988. *Incorporation: a theory of grammatical function changing*. Chicago: The University of Chicago Press.
- Barker, Chris. 1989. Extrametricality, the cycle, and Turkish word stress. *Phonology at Santa Cruz* 1. 1-34.
- Becker, Thomas. 1993. Back-formation, cross-formation, and 'bracketing paradoxes' in paradigmatic morphology. In Geert Booij and Jaap van Marle (eds.), *Yearbook of morphology*. Dordrecht: Kluwer. 1-26.
- Benua, Laura. 1995. Identity effects in morphological truncation. In Jill Beckman, Laura Walsh Dickey and Suzanne Urbanczyk (eds.), *University of Massachusetts Occasional Papers in Linguistics 18: Papers in Optimality Theory*. Amherst, MA: Graduate Linguistic Student Association. 77-136.
- Benua, Laura. 1996. Transderivational identity in Sundanese. Presented at the fifteenth West Coast Conference on Formal Linguistics.

- Bird, Steven. 1990. *Constraint-Based Phonology*. Doctoral Dissertation, Edinburgh University.
- Bird, Steven and T. Mark Ellison. 1994. One-Level Phonology: autosegmental rules and representations as finite automata. *Computational Linguistics* 20(1): 55-90.
- Bird, Steven and Ewan Klein. 1994. Phonological analysis in typed feature systems. *Computational Linguistics* 20(3): 455-491.
- Bochner, Harry. 1993. *Simplicity in generative morphology*. Berlin: Mouton de Gruyter.
- Bromberger, Sylvain and Morris Halle. 1989. Why phonology is different. *Linguistic Inquiry* 20: 51-70.
- Buckley, Eugene. 1993. *Theoretical aspects of Kashaya phonology and morphology*. Stanford: CSLI.
- Buckley, Eugene. 1995. Cyclicity as correspondence. Presented at the conference on the derivational residue in phonology. Tilburg University:
- Buckley, Eugene. 1996. Constraint domains in Kashaya. In José Camacho, Lina Choueiri and Maki Watanabe (eds.), *Proceedings of the fourteenth West Coast Conference on Formal Linguistics*. 47-62. Stanford: CSLI.
- Burzio, Luigi. 1994. *Principles of English stress*. Cambridge: Cambridge University Press.
- Carpenter, Bob. 1992. *The logic of typed feature structures*. Cambridge: Cambridge University Press.
- Chomsky, Noam and Morris Halle. 1968. *The sound pattern of English*. New York: Harper and Row.

- Chomsky, Noam, Morris Halle and Fred Lukoff. 1956. On accent and juncture in English. In Morris Halle (ed.), *For Roman Jakobson*. The Hague: Mouton. 68-80.
- Christdas, Prathima. 1988. *The phonology and morphology of Tamil*. Doctoral dissertation, Cornell University.
- Clements, George N. 1985. The geometry of phonological features. *Phonology Yearbook* 2: 225-252.
- Clements, George N. and Engin Sezer. 1982. Vowel and consonant disharmony in Turkish. In Harry van der Hulst and Norval Smith (eds.), *The structure of phonological representations, part 2*. Dordrecht: Foris. 213-255.
- Cohn, Abigail. 1989. Stress in Indonesian and bracketing paradoxes. *Natural Language and Linguistic Theory* 7: 167-216.
- Cole, Jennifer and John Coleman. 1993. Cyclic phonology with context-free grammars. In C. Canakis, G. Chan and J. Denton (eds.), *Papers from the parasession on the cycle in linguistic theory, twenty-eighth annual meeting of the Chicago Linguistic Society*. Chicago: Chicago Linguistic Society.
- Dolbey, Andrew Eric. 1996. Output optimization and cyclic allomorph selection. Presented at the West Coast Conference on Formal Linguistics.
- Dolbey, Andrew Eric and Cemil Orhan Orgun. 1996. Cyclicity versus output-output correspondence. Presented at the Trilateral phonology weekend, Stanford University.
- Fabb, Nigel. 1988. English suffixation is constrained only by selectional restrictions. *Natural Language and Linguistic Theory* 6: 527-540.

- Fillmore, Charles and Paul Kay. 1994. Grammatical constructions and linguistic generalizations: the *What's X doing Y?* construction. Manuscript, University of California, Berkeley.
- Fillmore, Charles J. and Paul Kay. 1996. Construction Grammar. Manuscript, University of California.
- Fillmore, Charles J., Paul Kay and Mary Catherine O'Connor. 1988. Regularity and idiomaticity in grammatical constructions: the case of let alone. *Language* 64: 501-538.
- Flickinger, Daniel. 1987. *Lexical rules in the hierarchical lexicon*. Doctoral dissertation, Stanford University.
- Flickinger, Daniel, Carl Pollard and Thomas Wasow. 1985. Structure sharing in lexical representation. In *Proceedings of the twenty-third ACL meeting*. 262-267.
- Gahl, Susanne. 1995. A prosodic condition on aperture nodes. Presented at the twenty-fifth meeting of the Northeastern Linguistic Society, Amherst, MA.
- Goldberg, Adele. 1992. The inherent semantics of argument structure: the case of the English ditransitive construction. *Cognitive Linguistics* 3(1): 37-74.
- Goldsmith, John. 1976. *Autosegmental Phonology*. Doctoral dissertation, Massachusetts Institute of Technology.
- Goldsmith, John. 1993. Harmonic Phonology. In John Goldsmith (ed.), *The last phonological rule*. Chicago: The University of Chicago Press. 21-60.
- Grijzenhout, Janet. 1995. *Irish consonant mutation and phonological theory*. Doctoral dissertation, OTS, Utrecht University.

- Hale, Kenneth and Lacayo Blanco. 1989. *Diccionario elemental del Ulwa (Sumu Meridional)*. Cambridge, MA: Center for Cognitive Science, Massachusetts Institute of Technology.
- Halle, Morris and K. P. Mohanan. 1985. Segmental phonology of Modern English. *Linguistic Inquiry* 16: 57-116.
- Halpern, Aaron. 1993. *On the morphology and placement of clitics*. Doctoral Dissertation, Stanford University.
- Hammond, Michael. 1991. Morphemic circumscription. In Geert Booij and Jaap van Marle (eds.), *Yearbook of Morphology*. Dordrecht: Kluwer. 195-209.
- Hankamer, Jorge. 1986. Finite state morphology and left to right phonology. In Mary Dalrymple et al. (eds.), *Proceedings of the fifth West Coast Conference on Formal Linguistics*. 40-52. Stanford: Stanford Linguistics Association.
- Hargus, Sharon. 1988. *The lexical phonology of Sekani*. New York: Garland Publishing, Inc.
- Hockett, Charles. 1954. Two models of grammatical description. *Word* 10: 210-231.
- Hopcroft, J. and J. Ullman. 1979. *Introduction to automata theory, languages, and computation*. Reading, MA: Addison-Wesley.
- Hualde, José Ignacio. 1988. *A lexical phonology of Basque*. Doctoral Dissertation, University of Southern California.
- Hualde, José Ignacio. 1989. The strict cycle condition and noncyclic rules. *Linguistic Inquiry* 20: 675-680.
- Hualde, José Ignacio. 1991. *Basque phonology*. New York: Routledge.

- Hyman, Larry M. 1994. Cyclic phonology and morphology in Cibemba. In Jennifer Cole and Charles Kisseberth (eds.), *Perspectives in phonology*. Stanford: CSLI. 81-112.
- Inkelas, Sharon. 1988. *Prosodic constituency in the lexicon*. Doctoral Dissertation, Stanford University.
- Inkelas, Sharon. 1993a. Deriving cyclicity. In Sharon Hargus and Ellen M. Kaisse (eds.), *Studies in Lexical Phonology*. San Diego: Academic Press. 75-110.
- Inkelas, Sharon. 1993b. Nimboran position class morphology. *Natural Language and Linguistic Theory* 11: 529-624.
- Inkelas, Sharon. 1994. Exceptional stress-attracting suffixes in Turkish: representations versus the grammar. Presented at the workshop on prosodic morphology, Utrecht University.
- Inkelas, Sharon and Cemil Orhan Orgun. 1994. Level economy, derived environment effects and the treatment of exceptions. In Richard Wiese (ed.), *Recent developments in Lexical Phonology*. Düsseldorf: Heinrich Heine Universität. 63-90.
- Inkelas, Sharon and Cemil Orhan Orgun. 1995. Level ordering and economy in the lexical phonology of Turkish. *Language* 71(4): 763-793.
- Inkelas, Sharon and Cemil Orhan Orgun. 1996. Level non-ordering in recursive morphology: evidence from Turkish. Presented at the U. C. Davis conference on morphology and its interactions with phonology and syntax.

- Inkelas, Sharon, Cemil Orhan Orgun and Cheryl Zoll. 1994. The big bang: subregularities as cogrammars. Presented at the Trilateral Phonology Weekend, University of California, Santa Cruz.
- Itô, Junko. 1990. Prosodic minimality in Japanese. In K. Deaton, Manuela Noske and M. Ziolkowski (eds.), *CLS 26: parasession on the syllable in phonetics and phonology*. 213-239. Chicago: Chicago Linguistic Society.
- Itô, Junko and Armin Mester. 1993. Japanese phonology: constraint domains and structure preservation. LRC-93-06, University of California, Santa Cruz.
- Itô, Junko and Armin Mester. 1995. Japanese phonology. In John A. Goldsmith (ed.), *The handbook of phonological theory*. Cambridge, MA: Blackwell. 816-838.
- Itô, Junko, Armin Mester and Jaye Padgett. 1995. Licensing and underspecification in Optimality Theory. *Linguistic Inquiry* 26(4): 571-613.
- Janda, Richard D. 1983. Morphemes aren't something that grows on trees: morphology as more the phonology than the syntax of words. In John F. Richardson, Mitchell Marks and Amy Chukerman (eds.), *Papers from the parasession on the interplay of phonology, morphology, and syntax*. 79-95. Chicago Linguistic Society.
- Johnson, C. Douglas. 1972. *Formal aspects of phonological description*. The Hague: Mouton.
- Kaplan, Ronald and Joan Bresnan. 1982. Lexical-Functional Grammar: a formal system for grammatical representation. In Joan Bresnan (ed.), *The mental representation of grammatical relations*. Cambridge, MA: MIT Press. 173-281.

- Karttunen, Lauri. 1993. Finite-state constraints. In John Goldsmith (ed.), *The last phonological rule*. Chicago: The University of Chicago Press. 173-194.
- Kennedy, Chris. 1994. Morphological alignment and head projection. In Jason Merchant, Jaye Padgett and Rachel Walker (eds.), *Phonology at Santa Cruz*. Santa Cruz: Linguistics Research Center, University of California. 47-64.
- Kenstowicz, Michael. 1994. *Phonology in generative grammar*. Cambridge, MA: Blackwell.
- Kenstowicz, Michael. 1995. Base-identity and uniform exponence: alternatives to cyclicity. Manuscript, Massachusetts Institute of Technology.
- Kiparsky, Paul. 1973. Elsewhere in phonology. In Stephen Anderson and Paul Kiparsky (eds.), *A festschrift for Morris Halle*. New York: Holt, Rinehart and Winston. 93-106.
- Kiparsky, Paul. 1982. Lexical morphology and phonology. In I.-S. Yang (ed.), *Linguistics in the morning calm*. Seoul: Hanshin. 3-91.
- Kiparsky, Paul. 1985. Some consequences of Lexical Phonology. *Phonology Yearbook 2*: 85-138.
- Kisseberth, Charles W. 1970. On the functional unity of phonological rules. *Linguistic Inquiry* 1(3): 307-322.
- Koenig, Jean-Pierre. 1994. *Lexical underspecification and the syntax/semantics interface*. Doctoral Dissertation, University of California.

- Koenig, Jean-Pierre and Daniel Jurafsky. 1994. Type underspecification and on-line type construction in the lexicon. Presented at the thirteenth West Coast Conference on Formal Linguistics.
- Koenig, Jean-Pierre, C. Orhan Orgun and Daniel Jurafsky. 1996. Constraint-based morphology. Presented at the third international conference on HPSG, Marseille, France.
- Koskenniemi, Kimmo. 1983. Two level morphology: a general computational model for word-form recognition and production. Publication, Department of General Linguistics, University of Helsinki.
- Krieger, Hans-Ulrich and John Nerbonne. 1993. Feature-based inheritance networks for computational lexicons. In Ted Briscoe, Anne Copestake and Valeria de Paiva (eds.), *Default inheritance within unification-based approaches to the lexicon*. Cambridge: Cambridge University Press.
- Krieger, Hans-Ulrich, Hannes Pirker and John Nerbonne. 1993. Feature-based allomorphy. In *Proceedings of the 31st annual meeting of the Association for Computational Linguistics*. 140-147.
- Lakoff, Geoger. 1987. *Women, fire and dangerous things*. Chicago: The Chicago University Press.
- Lakoff, George. 1993. Cognitive Phonology. In John Goldsmith (ed.), *The last phonological rule*. Chicago: The University of Chicago Press. 117-145.
- Leben, Will. 1973. *Suprasegmental phonology*. Doctoral dissertation, Massachusetts Institute of Technology.

- Lewis, Geoffrey. 1967. *Turkish grammar*. Oxford: Clarendon Press.
- Lieber, Rochelle. 1980. *On the organization of the lexicon*. Doctoral Dissertation, Massachusetts Institute of Technology.
- McCarthy, John. 1979. *Formal problems in Semitic phonology and morphology*. Doctoral dissertation, Massachusetts Institute of Technology.
- McCarthy, John. 1996a. Faithfulness in prosodic morphology: Rotuman revisited. Manuscript, University of Massachusetts, Amherst.
- McCarthy, John. 1996b. Phonological opacity in Optimality Theory. Manuscript, University of Massachusetts, Amherst.
- McCarthy, John and Alan Prince. 1986. Prosodic morphology. Manuscript, University of Massachusetts, Amherst and Brandeis University.
- McCarthy, John and Alan Prince. 1990. Foot and word in Prosodic Morphology: the Arabic broken plurals. *Natural Language and Linguistic Theory* 8: 209-284.
- McCarthy, John and Alan Prince. 1993. Generalized Alignment. In Geert Booij and Jaap van Marle (eds.), *Yearbook of Morphology*. Dordrecht: Kluwer. 79-153.
- McCarthy, John and Alan Prince. 1994a. An overview of prosodic morphology, part 1: templatic form in reduplication. Workshop on prosodic morphology, Utrecht University.
- McCarthy, John and Alan Prince. 1994b. An overview of prosodic morphology, part 2: template satisfaction. Workshop on prosodic morphology, Utrecht University.
- McCarthy, John and Alan Prince. 1995. Faithfulness and reduplicative identity. In Jill Beckman, Laura Walsh Dickey and Suzanne Urbanczyk (eds.), *University of*

- Massachusetts Occasional Papers in Linguistics 18: Papers in Optimality Theory.*
Amherst, MA: Graduate Linguistic Student Association. 249-384.
- Mester, Armin. 1995. The quantitative trochee in Latin. *Natural Language and Linguistic Theory.*
- Mohanan, K. P. 1982. *Lexical Phonology.* Doctoral Dissertation, Stanford University.
- Mohanan, K. P. 1986. *The theory of Lexical Phonology.* Dordrecht: D. Reidel Publishing Company.
- Myers, Scott. 1992. The phonology and morphology of INFL in Bantu. Manuscript, University of Texas, Austin.
- Nespor, Marina and Irene Vogel. 1986. *Prosodic Phonology.* Dordrecht: Foris.
- Odden, David. 1993. Interaction between modules in lexical phonology. In Sharon Hargus and Ellen M. Kaisse (eds.), *Studies in Lexical Phonology.* San Diego: Academic Press. 111-144.
- Odden, David. 1994. Adjacency parameters in phonology. *Language* 70(2): 289-330.
- Orgun, Cemil Orhan. 1993. Morphological change in Turkic. Manuscript, University of California, Berkeley.
- Orgun, Cemil Orhan. 1994a. Grammaticalization in Uighur and Turkish. University of California, Berkeley.
- Orgun, Cemil Orhan. 1994b. Monotonic Cyclicity and Optimality Theory. In Mercè González (ed.), *Proceedings of the twenty-fourth meeting of the Northeastern Linguistic Society.* Amherst, MA: Graduate Linguistic Student Association. 461-474.

- Orgun, Cemil Orhan. 1994c. Monotonic Cyclicity and Suspended Affixation. Linguistics department colloquium, Edinburgh University.
- Orgun, Cemil Orhan. 1995a. A declarative theory of phonology-morphology interleaving. Presented at the conference on the derivational residue in phonology, Tilburg University.
- Orgun, Cemil Orhan. 1995b. Flat vs. branching morphological structures: the case of Suspended Affixation. In Jocelyn Ahlers, Leela Bilmes, Joshua S. Guenter, Barbara A. Kaiser and Ju Namkung (eds.), *Proceedings of the Twenty-First Annual Meeting of the Berkeley Linguistics Society*. 252-261. Berkeley, CA: Berkeley Linguistics Society.
- Orgun, Cemil Orhan. 1995c. Reference to lexical types in Sign-Based Morphology. Linguistics department colloquium, Tilburg University.
- Orgun, Cemil Orhan. 1996a. Correspondence and identity constraints in two-level Optimality Theory. In José Camacho, Lina Choueiri and Maki Watanabe (eds.), *Proceedings of the Fourteenth West Coast Conference on Formal Linguistics*. Stanford: CSLI. 399-413.
- Orgun, Cemil Orhan. 1996b. Suspended Affixation: a new look at the phonology-morphology interface. In Ursula Kleinhenz (ed.), *Interfaces in phonology*. Berlin: Akademie Verlag. 251-261.
- Orgun, Cemil Orhan and Ronald Sprouse. 1996a. Beyond MPARSE. Presented at the Trilateral Phonology Weekend, Stanford University.

- Orgun, Cemil Orhan and Ronald Sprouse. 1996b. When the best isn't good enough. Presented at the Western Conference on Linguistics.
- Pesetsky, David. 1979. Russian morphology and lexical theory. Manuscript, Massachusetts Institute of Technology.
- Pinker, Steven. 1994. *The language instinct*. Cambridge, MA: MIT Press.
- Pollard, Carl and Ivan A. Sag. 1987. *Information-based syntax and semantics, volume 1: fundamentals*. Stanford: CSLI.
- Pollard, Carl and Ivan A. Sag. 1994. *Head-driven Phrase Structure Grammar*. Chicago: The University of Chicago Press.
- Poser, William J. 1982. Phonological representation and action-at-a-distance. In Harry van der Hulst and Norval Smith (eds.), *The structure of phonological representations, part 1*. Dordrecht: Foris. 121-158.
- Poser, William J. 1984. *The phonetics and phonology of tone and intonation in Japanese*. Doctoral dissertation, Massachusetts Institute of Technology.
- Press, Ian. 1986. *A grammar of modern Breton*. Berlin: Mouton de Gruyter.
- Prince, Alan and Paul Smolensky. 1993. Optimality Theory: constraint interaction in generative grammar. Manuscript, Rutgers University and the University of Colorado at Boulder.
- Pullum, Geoffrey K. and Arnold M. Zwicky. 1991. A misconceived approach to morphology. In Dawn Bates (ed.), *Proceedings of the Tenth Western Conference on Formal Linguistics*. 387-398. Stanford: CSLI.

- Raffelsiefen, Renate. 1992. A nonconfigurational approach to morphology. In Mark Aronoff (ed.), *Morphology now*. Albany, NY: State University of New York Press. 133-162.
- Rhodes, Richard. 1992. What is a morpheme? A view from Construction Grammar. In Laura A. Buszard-Welcher, Lionel Wee and William Weigel (eds.), *Proceedings of the eighteenth annual meeting of the Berkeley Linguistics Society*. Berkeley: Berkeley Linguistics Society. 409-423.
- Rice, Keren. 1989. *A grammar of Slave*. Berlin: Mouton de Gruyter.
- Riehemann, Susanne. 1993. *Word formation in lexical type hierarchies*. Master's thesis, Düsseldorf University.
- Riehemann, Susanne. 1994. Morphology and the hierarchical lexicon. Manuscript, Stanford University.
- Schachter, Paul and F. T. Otones. 1972. *Tagalog reference grammar*. Berkeley: University of California Press.
- Scobbie, James M. 1991. *Attribute value phonology*. Doctoral dissertation, University of Edinburgh.
- Selkirk, Elisabeth. 1982. *The syntax of words*. Cambridge, MA: MIT Press.
- Sezer, Engin. 1981a. The k/0 alternation in Turkish. In George N. Clements (ed.), *Harvard studies in phonology*. Bloomington: Indiana University Linguistics Club.
- Sezer, Engin. 1981b. On n on-final stress in Turkish. *Journal of Turkish Studies (TÜBA)* 5: 61-69.

- Shieber, Stuart. 1986. *An introduction to unification-based approaches to grammar*. Stanford: CSLI.
- Shih, Chi-Lin. 1986. *The prosodic domain of tone sandhi in Chinese*. Doctoral dissertation, University of California, San Diego.
- Siegel, Dorothy. 1974. *Topics in English morphology*. Doctoral dissertation, Massachusetts Institute of Technology.
- Siegel, Dorothy. 1978. The adjacency condition and the theory of morphology. In Mark J. Stein (ed.), *Proceedings of the eighth annual meeting of the North Eastern Linguistic Society*. Amherst, MA: Graduate Linguistic Student Association. 189-197.
- Spencer, Andrew. 1994. Syllabification in Chukchee. In Richard Wiese (ed.), *Recent developments in Lexical Phonology*. Düsseldorf: Heinrich Heine Universität. 205-226.
- Sproat, Richard. 1992. *Morphology and computation*. Cambridge, MA: MIT Press.
- Stump, Gregory. 1988. Non-local spirantization in Breton. *Linguistics* 24: 457-481.
- Stump, Gregory. 1995. Stem formation, stem indexing, and stem choice. Manuscript, University of Kentucky.
- Szpyra, Jolanta. 1989. *The phonology-morphology interface: cycles, levels and words*. London: Routledge.
- Underhill, Robert. 1976. *Turkish grammar*. Cambridge, MA: MIT Press.

- Walther, Markus. 1995. A strictly lexicalized approach to phonology. In James Kibury and Richard Wiese (eds.), *Integrative Ansätze in der Computerlinguistik*. Düsseldorf: Heinrich-Heine Universität.
- Zimmer, Karl and Barbara Abbott. 1978. The k/0 alternation in Turkish: some experimental evidence for its productivity. *Journal of Psycholinguistic Research* 7: 35-46.
- Zonneveld, Wim. 1978. *A formal theory of exceptions in generative phonology*. Lisse: The Peter de Ridder Press.
- Zwicky, Arnold M. 1994. Morphological metageneralizations: morphology, phonology, and morphonology. Presented at the Foreign Language Conference, University of Kentucky.